

EVO

EVO 2T



2009 - 2015



COD. 00744050 000

MANUALE DI OFFICINA
WORKSHOP MANUAL
MANUEL D'ATELIER
WERKSTATTHANDBUCH
MANUAL DE TALLERES



Beta
the play bike

FOREWORD	2
1 REMOVING THE ENGINE FROM THE VEHICLE	4
1.1 Exhaust manifold	5
1.2 Engine protection plat	5
1.3 Transmission oil plug	5
1.4 Water cooling radiator	6
1.5 Flywheel casing, clutch actuator and pinion	8
1.6 Electronic control box	8
1.7 Carburettor clamp	9
1.8 Quadripole and monopole connector release	9
1.9 Engine bolts	10
2 DISASSEMBLING THE ENGINE	11
2.1 Thermal unit	11
2.1.1 Head	12
2.1.2 Cylinder	13
2.1.3 Piston	13
2.2 Intake system	14
2.3 Ignition system	14
2.3.1 Flywheel	15
2.3.2 Pick-up and stator	16
2.4 Clutch unit	17
2.5 Primary gear	19
2.6 Start-up devic	20
2.7 Gearbox unit	21
2.7.1 External transmission control	21
2.7.2 Internal transmission control and transmission gears	22
2.8 Motor shaft	22
2.9 Bearings and oil seals	23
3 ASSEMBLING AND TESTING THE ENGINE	24
3.1 Testing the motor shaft and connecting rod	24
3.2 Mounting the complete motor shaft	25
3.3 Gearbox unit: testing and reassembling	25
3.3.1 Testing the toothed wheels and shafts	25
3.3.2 Testing the forks, fork pins and desmodromic device	26
3.3.3 Assembling the internal transmission control	27
3.4 Closing the engine casing	29
3.5 External transmission control	30
3.5.1 Testing the complete gear shaft	30
3.5.2 Assembling the external transmission control	31
3.6 Start-up device	32
3.6.1 Testing the ignition shaft and the assembly	32

3.6.2 Mounting the start-up device	33
3.7 Primary gear and clutch unit	34
3.7.1 Testing the clutch bell and replacing the silent-block	35
3.7.2 Testing the clutch discs	36
3.7.3 Testing the springs	37
3.7.4 Testing the clutch drum	37
3.8 Assembling the clutch	38
3.9 Internal cover of the clutch	40
3.10 Ignition system	41
3.10.1 Testing the ignition stator	41
3.10.2 Stator and pick-up winding	41
3.10.3 Flywheel	42
3.11 Thermal unit	43
3.11.1 Testing the piston, piston pin and piston rings	43
3.11.2 Testing the cylinder and head	44
3.12 Assembling the piston, piston ring, piston pin, crank case/cylinder gasket and cylinder	46
3.12.1 Thickness check of cylinder/crankcases gasket	47
3.13 Assembling the head	49
3.14 Intake system	50
3.14.1 Testing the lamella pack	50
3.14.2 Mounting the intake system	50
3.15 Start-up and gear lever	50
3.16 Water pump unit	51
3.16.1 Disassembling and reassembling the water pump	51
4 MOUNTING THE ENGINE ON THE VEHICLE AND REPOSITIONING THE COMPONENTS	52
4.1 General guidelines	52
4.2 Coupling the engine to the frame	53
4.3 Coupling the clutch actuator, pinion and flywheel casing	54
4.4 Electronic control box	55
4.5 Connecting the engine cable to the main system and mounting the rear mudguard	55
4.6 Remounting the complete water radiator and coil	56
4.7 Engine protection plate	57
4.8 Exhaust manifold	58
Table of tightening torques of the engine components	59
Table of tightening torques of the engine-frame	60
Engine specifications	60
Recommended lubricants and liquid	60

FOREWORD

This manual has been drafted for the motorcycle user and Technical Support operator, whereby it provides understandable information pertaining to the necessary operations of engine inspection, maintenance and repair.

This manual must be thoroughly read before operating the engine. Engine life is prolonged by having a good knowledge of all the components and all the procedures to be followed when carrying out inspection and maintenance operations.

Schematic illustrations that highlight the subject matter have been included within the paragraphs for the reader to immediately understand that being read.

Informative note

Betamotor S.p.A. is committed to continuously improve its products. For this reason, there may be slight differences between that provided in this manual and the vehicle onto which you are to perform maintenance and/or repair operations. The Betamotor S.p.A. models are exported to many countries where different standards apply in relation to the Highway Code and approval procedures. Betamotor S.p.A. relies on your comprehension of the information, therefore it considers it necessary to reserve the right to effect changes to its products and technical documentation at any given time and without prior notice.

Respecting and protecting the environment

All that we do has repercussions on the entire planet and its resources. In order to protect the Community, Betamotor S.p.A. raises awareness amongst its Clients and Technical Support operators in order for them to use the vehicle and dispose of its parts in compliance with applicable regulations in terms of environmental pollution, disposal and recycling waste.

SAFETY

Carbon Monoxide

- The exhaust gases contain carbon monoxide, which is a poisonous gas. Carbon monoxide can cause loss of consciousness and lead to death. When starting-up the engine, ensure the area is well-ventilated. Never start-up the engine indoors.
- The engine can only be started-up indoors if there are appropriate means to evacuate exhaust gases.

Petrol

- Petrol is extremely flammable and in certain conditions, explosive.
- Keep sources of heat, sparks and flames away from the work area.
- Always work in a well-ventilated area.
- Never use petrol as a cleaning solvent. Avoid handling petrol, unless absolutely necessary.
- Do not use petrol to clean the components – use compressed air.
- Keep out of reach of children.

Engine oil

- Engine oil can cause skin diseases if repeated and/or prolonged contact is made with skin.
- If engine oil comes in contact with your skin, wash with soap and water as soon as possible.
- If contact is made with your eyes, rinse thoroughly with water and consult a doctor.
- If swallowed, do not induce vomiting so as to prevent it from being absorbed into the lungs. Consult a doctor immediately. If you think the product has been absorbed into the lungs, the person in question is to be taken immediately to hospital.
- Spent oil contains hazardous substances that are harmful to the environment. When this is replaced, you must have the right equipment for its disposal in compliance with applicable regulations.
- Do not dispose of spent oil in the environment.
- Keep out of reach of children.



Coolant

- In certain situations, the ethylene glycol contained in the coolant is flammable and its flame is invisible. Should the ethylene glycol ignite, even though its flame is invisible, it will cause burns.
- Prevent the coolant from coming into contact with hot parts. These parts can be hot enough to ignite the flame.
- The coolant (ethylene glycol) may cause skin irritation and is poisonous if swallowed.
- If the coolant comes into contact with your skin, immediately remove any contaminated clothes or shoes and wash with soap and water. If contact is made with your eyes, rinse thoroughly with clean water and consult a doctor immediately. If swallowed, do not induce vomiting so as to prevent it from being absorbed into the lungs. The person in question must drink clean water and must also be taken immediately to hospital. The product must be shown to the medical staff.
- In case of exposure to a high concentration of vapours, the person in question must be moved to an unpolluted area and if necessary, a doctor must be called.
- Do not remove the radiator cap when the engine is still hot. Since the coolant is under pressure, it can spurt out violently and cause burns.

- Coolant contains hazardous substances that are harmful to the environment. When replacing the coolant you must have the right equipment for its disposal, in compliance with applicable regulations.
- Do not dispose of coolant in the environment.
- Keep out of reach of children.

Hot parts

- The engine and the exhaust system become very hot and remain so for some time, even after the engine is switched off. Wait for them to cool before handling or intervening in parts that are around them. Also use insulating gloves.

WARNINGS

The information contained in this paragraph is important for any operation to be carried out correctly on the engine without causing damage.

- Thoroughly clean the motorcycle before disassembling any parts.
- When disassembling, clean all the components and put them in containers maintaining the same order of disassembly.
- Always use special tools where necessary and every time this is required.
- Always use the adhesives, sealants and lubricants where stipulated. Adhere with the guidelines given regarding their technical specifications.
- Always replace parts such as seals, O-rings and safety washers with brand new parts.
- When loosening or tightening nuts or screws, always start with the larger ones or from the centre. Always adhere with the tightening torque values given.
- Solely Betamotor original parts are to be used.



REMOVING THE ENGINE FROM THE VEHICLE

Before removing the engine from the vehicle, thoroughly clean the entire motorbike and let it dry, then place it on a stable kickstand.

Pictures 1 and 2 show the engine coupled with the vehicle, seen from both the left and right side, showing all the main components that must be removed for the engine to be removed from the vehicle.



Picture 1
Left view of the engine coupled with the vehicle.



Picture 2
Right view of the engine coupled with the vehicle.

- 1- Exhaust manifold**
- 2- Engine protection plate**
- 3- Oil drain plug**
- 4- Cooling radiator**

- 5- Flywheel casing**
- 6- Clutch actuator**
- 7- Pinion**
- 8- Electronic control box**
- 9- Carburettor clamp**





The two bolts of the exhaust manifold flange.

1.1 EXHAUST MANIFOLD

Unscrew the two bolts that fasten the manifold flange to the cylinder in order to remove the exhaust manifold.

It is recommended to turn the handlebar to one side to facilitate the operation.



The four screws of the engine protection plate.

1.2 ENGINE PROTECTION PLATE

Remove the engine protection plate by removing the four fastening screws from the frame. Should the protection plate be particularly deformed, it is recommended to carefully beat it back into place or replace it.



The plug where the transmission oil is drained from.

1.3 TRANSMISSION OIL PLUG

Drain the transmission oil by removing the relative plug.

Caution!

Spent oil contains hazardous substances that are harmful to the environment. When replacing the oil you must have the right equipment for its disposal, in compliance with applicable regulations.

Do not dispose of spent oil in the environment.



Liquid drain plug.



The screw that fastens the coil support to the radiator.



The screws that fasten the left side to the tank.

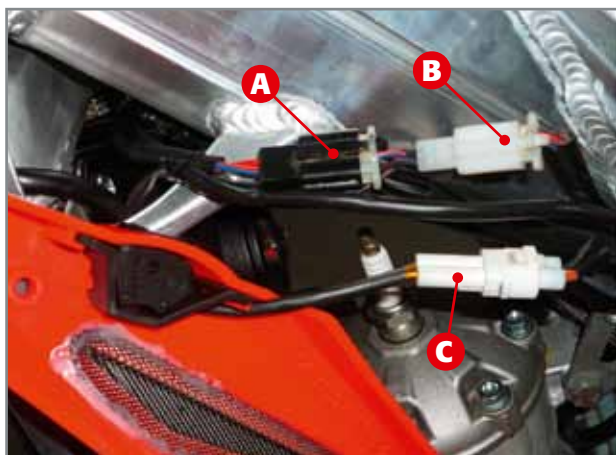

Connectors A, B and C.

1.4 WATER COOLING RADIATOR

Before removing the water radiator you should empty the cooling system by removing the drain screw found on the pump body. Open the radiator cap and slightly tilt the vehicle to the left to facilitate the liquid flow.

It is recommended to perform this operation after having removed the protection plate so as to prevent the coolant from remaining on the plate.

The liquid can be reused if it has a clear blue colour.

Loosen the screw that fastens the coil support to the radiator. Once this is implemented, the coil and its support will be fastened to the vehicle solely by the high and low voltage cables.

In order to prevent the cables from being stretched, it is recommended to disconnect the pipette -high voltage cable- from the spark plug and fasten the frame with clamps.

You must disconnect the thermal bulb and the fan from the electrical system in order to remove the radiator. Loosen the two screws that fasten the left side to the tank in order to access the relative connectors. Then disconnect connectors **A** and **B**, respectively, from the electric fan and the thermal bulb.

*To loosen the left side from the vehicle completely, simply disconnect connector **C** that connects the map switch to the electronic control box.*



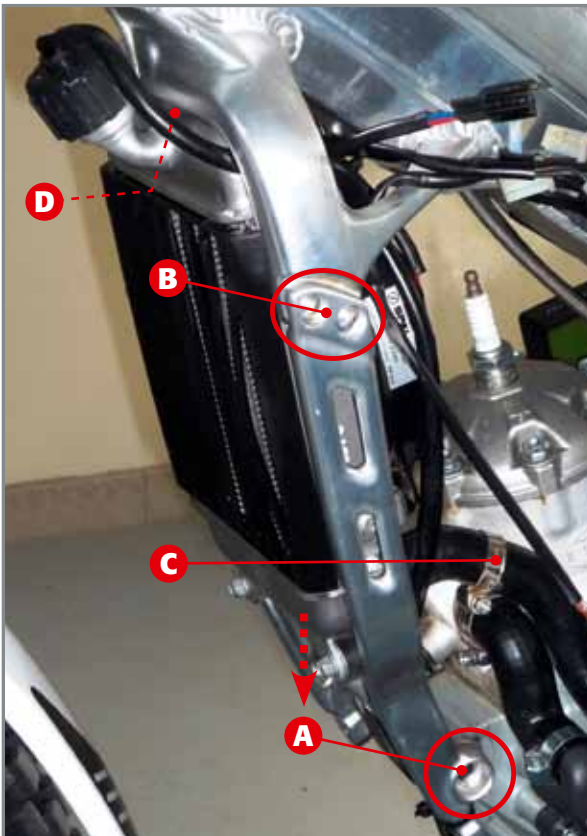

Disassembling the radiator.



Complete radiator: the upper pin (D) is highlighted.

- 1.4 Unscrew the lower pin **A**, the four upper screws **B** (two on each side) and loosen the two clamps **C** (one on each side) that connect the radiator to the engine. Slightly turn the radiator forward and remove its two water pipes, simultaneously. Lower the radiator in such a way that the upper pin **D** comes out of its housing.



The three screws of the flywheel casing.



The four screws of the clutch actuator.

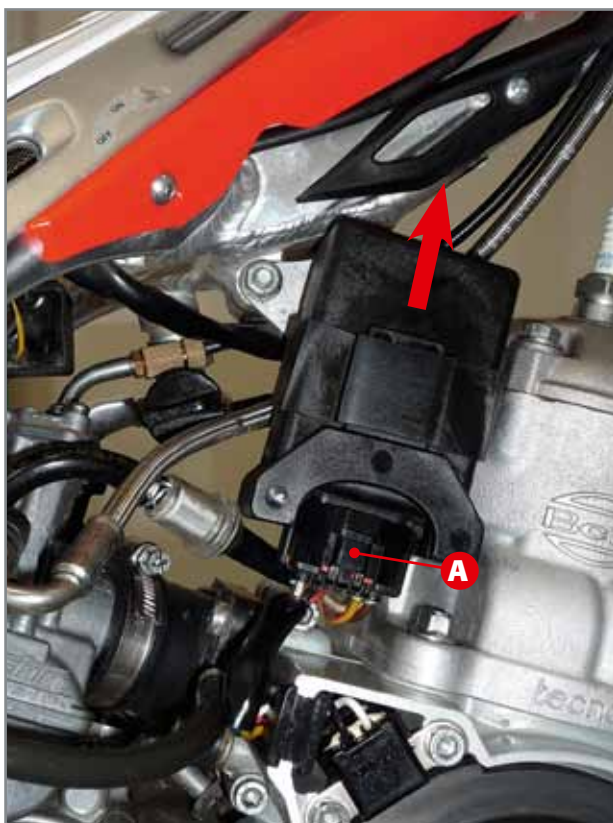

Extracting the control box from its support.

1.5 FLYWHEEL CASING, CLUTCH ACTUATOR AND PINION

Loosen the three screws that fasten the flywheel casing to the engine. This will let you access the clutch actuator, which is removed from the engine by loosening the four screws indicated. Remove the pinion by removing the specific Seeger ring.

1.6 ELECTRONIC CONTROL BOX

Disconnect the electronic control box from the electrical system by pressing the flap A on the connector, then pull upwards for the control box to emerge from its support.

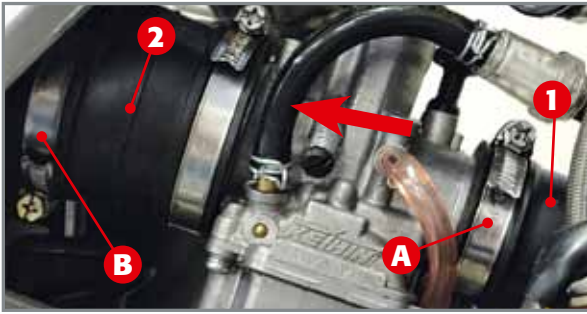

Removing the carburettor from the engine.

1.7 CARBURETTOR CLAMP

In order to remove the carburettor from the engine you must loosen the two flaps **A** and **B** that fold around the intake collector **1** and sleeve **2** respectively, which connect it to the filter box. Then pull the carburettor towards the back part of the vehicle until it is released from its housing inside the container.

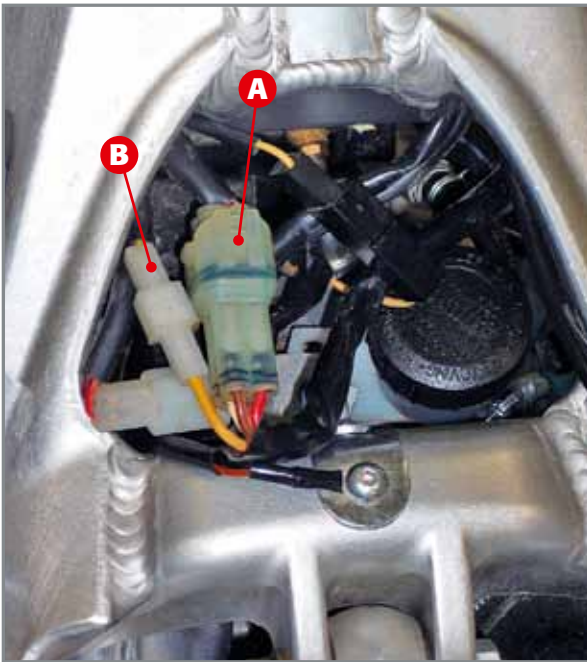

Quadripole and monopole connector.

1.8 QUADRIPOLE AND MONOPOLE CONNECTOR RELEASE

The engine is connected to the main system by means of a quadripole and monopole connector, which must be disconnected for the engine to be removed from the vehicle. Loosen the screws that fasten the rear mud-guard to the frame and remove the mud-guard by disconnecting the power cable of the backlight.

Remove the clamps and pull the cables that are along the left side of the frame, towards the back part of the vehicle.

Pull the flap **A** that is on the female quadripole connector and then separate it from the male connector.

Disconnect the monopole connector **B** and remove the cable, downwards from the side of the engine.

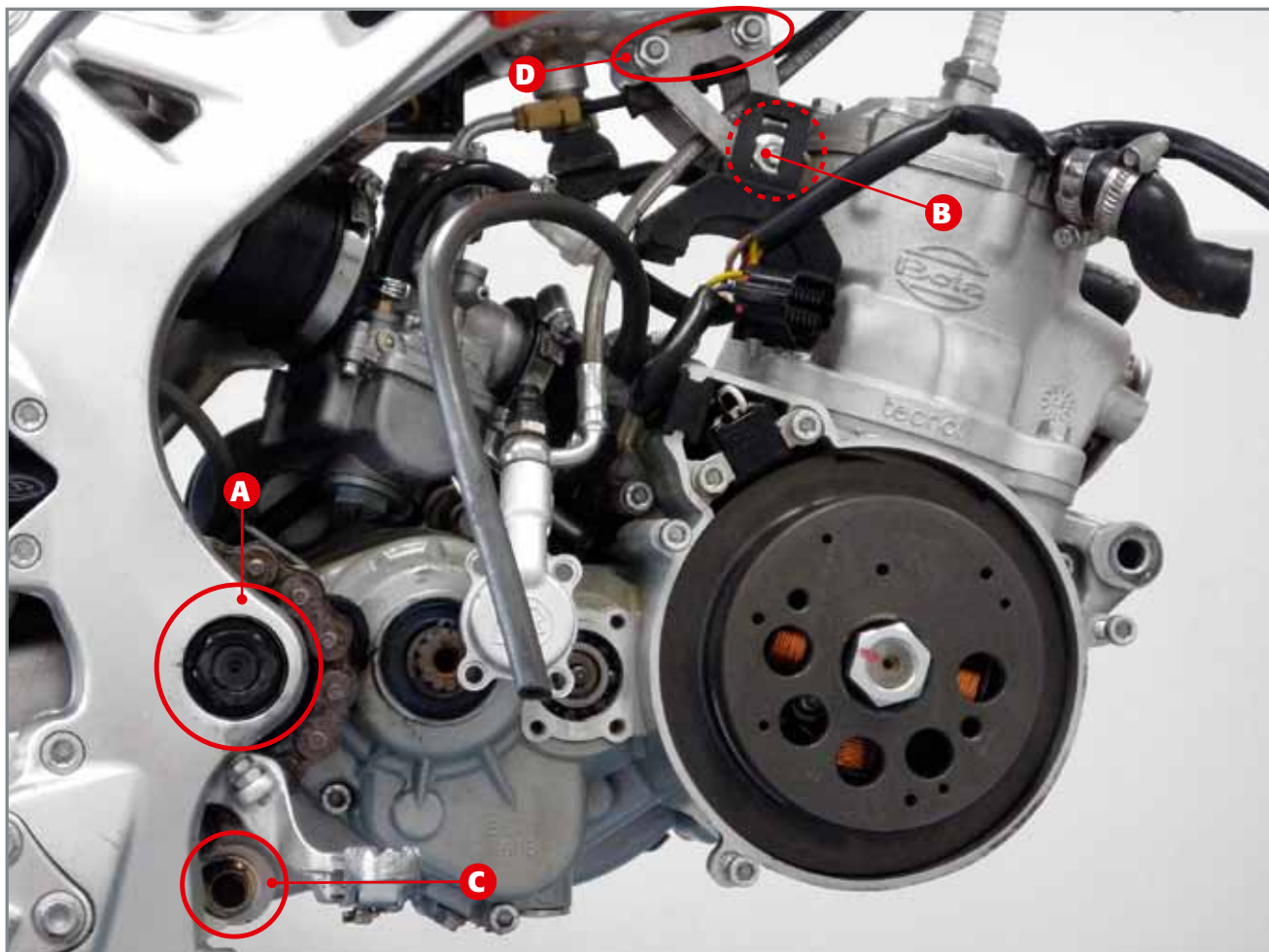
**ENGINE BOLTS:**

- A) swing arm bolt;
- B) upper bolt;
- C) lower bolt;
- D) bracket bolts.



Swing arm bolt not being removed completely.

1.9 ENGINE BOLTS

The engine is fastened to the frame by four bolts: one at the front, one at the bottom, one at the top and one at the back. The description of the first of these four bolts being removed is found in paragraph 1.4, removal of the radiator. It is recommended to remove the engine from the frame by first removing bolt **A** at the back (swing arm bolt), then the upper bolt **B** and lastly the lower bolt **C**. The control box support will also be removed when the nut from bolt **B** is removed.

It is recommended to also loosen both bolts **D**, so as to facilitate removing and reassembling the engine onto the frame.

Please note that bolt B does not have to be removed completely for the engine to be removed. In fact, it must be loosened enough for the engine to be removed from the frame, thereby you will avoid removing the swing arm from the frame.



DISASSEMBLING THE ENGINE

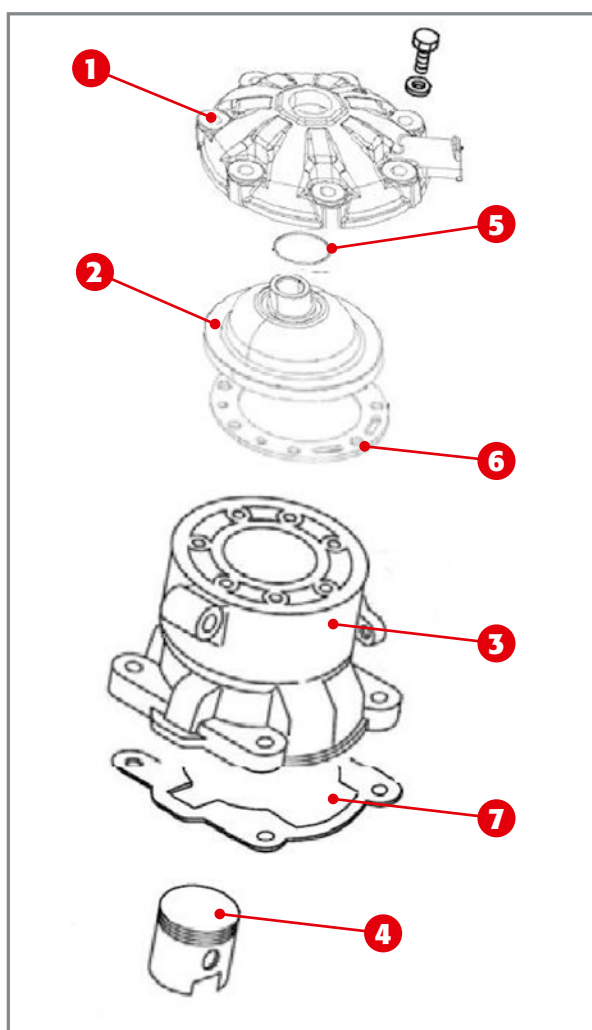

Exploded view of the thermal unit.

Fasten the engine onto a solid and safe support so as to work with ease and safely. Then proceed as follows.

2.1 THERMAL UNIT

The thermal unit consists of the external cap **1**, the combustion chamber **2**, the cylinder **3** and the piston **4**. Assembly is completed with the O-ring **5**, the seal head **6**, the casing-cylinder seal **7** and the seven copper washers with the respective special screws M7x31.

The description of these parts being disassembled is found further on.

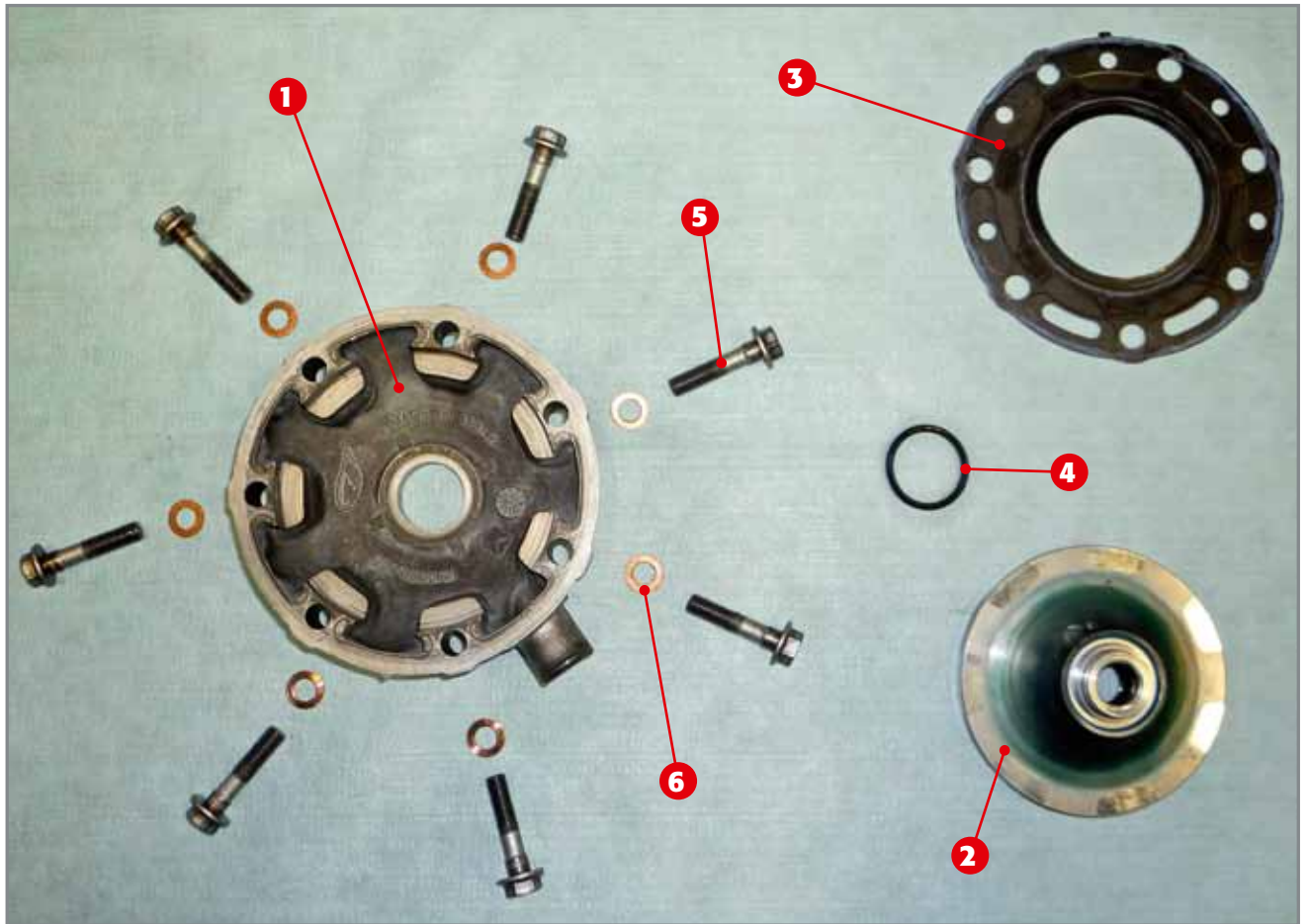

HEAD ASSEMBLY.

- 1) External cap.
- 2) Combustion chamber.
- 3) Seal head.
- 4) O-ring.
- 5) Screws.
- 6) Copper washers 7x12x0.5

2.1.1 HEAD

Once the water circuit is emptied, it is recommended to blow compressed air into the sleeve connected to the head in order to be sure there is no fluid in the thermal unit.

Once the water sleeve is disconnected, loosen the spark plug, then the seven screws that fasten the external cap to the cylinder. Lift the head and once it is placed on a level surface, remove the spark plug. Lightly press the spark plug housing to decouple the combustion chamber from the external cap. If necessary, proceed with the descaling procedures of the combustion chamber and the internal part of the cap.

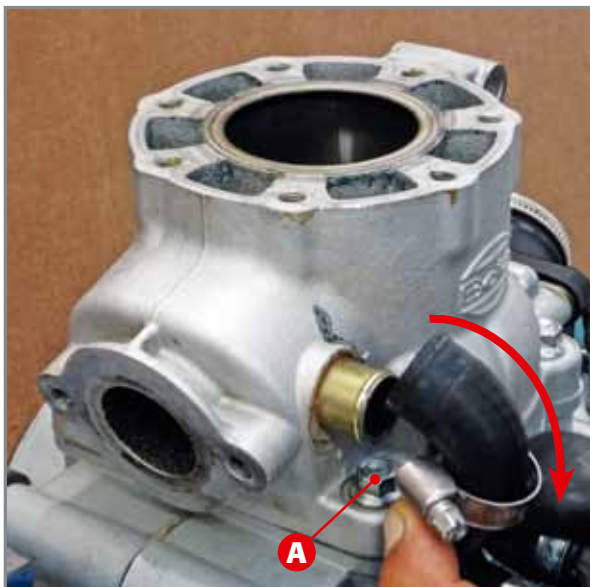

Disassembling the cylinder.

2.1.2 CYLINDER

Remove the rubber tube that connects the cylinder to the water pump after having loosened the clamp; turn the motor shaft until the piston lies in the top dead centre and loosen the four bolts A that fasten the cylinder to the base unit. Then gently remove the cylinder by pulling it upwards.

Note: Should the cylinder be stuck to the base unit, gently strike the cylinder in various points with a rubber mallet.

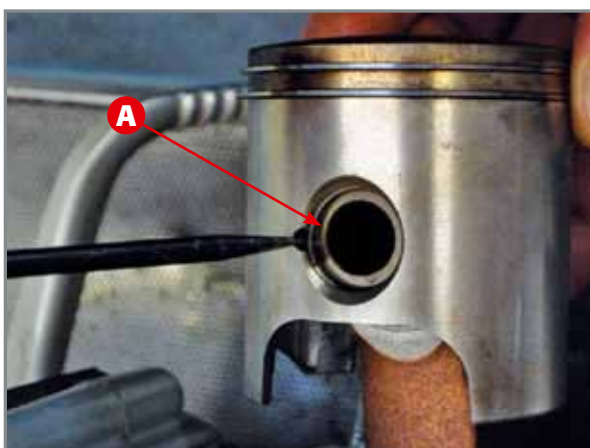

Disassembling snap ring A.

2.1.3 PISTON

Place a clean cloth in the area below the piston, between the two casings, in order to prevent any foreign objects or solid residues from falling into the base unit. Then use a suitable tool to remove the piston pin lock ring A. Working from the other side, unthread piston pin B as much as is needed to release the piston assembly from the connecting rod. Remove the bearings assembly C from the connecting rod.



Complete piston: A) piston pin lock ring; B) piston pin; C) bearings assembly; D) piston.

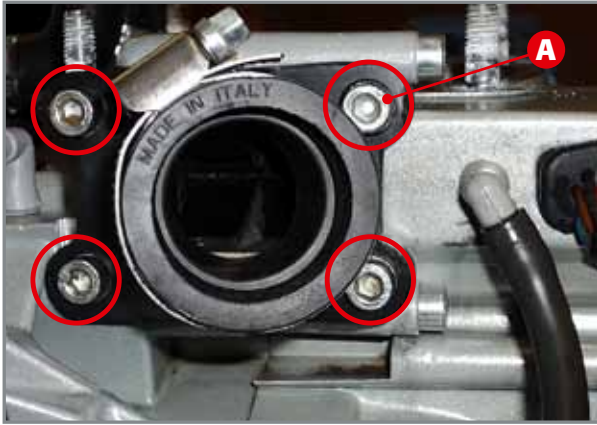

Disassembling the intake manifold and lamella pack.

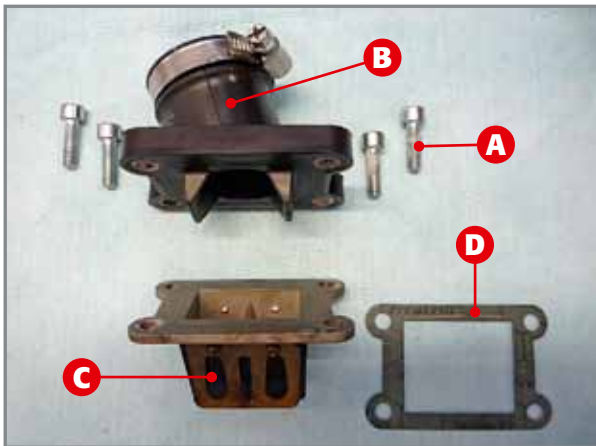

EXPLODED VIEW OF THE INTAKE CONTAINER.

- A) screws;
- B) intake container;
- C) lamella pack;
- D) seal.

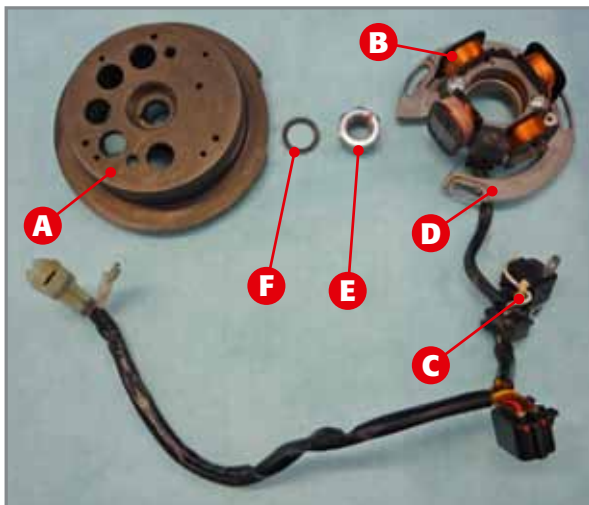

Complete ignition system.

2.2 INTAKE SYSTEM

The intake system consists of the intake manifold **B** and the lamella pack **C**. To disassemble this, remove the four screws **A** that fasten the intake manifold and the lamella pack to the casings. Decouple the intake manifold and seal **D** from the lamella pack.

2.3 IGNITION SYSTEM

The ignition system consists of the flywheel **A**, the stator windings **B** (*stator for short*) and the magnetic pick-up **C**. The complete stator is fastened to the support **D** with two screws and the support is fastened to the right casing with three screws. The flywheel is fastened to the motor shaft by the special nut **E**. The safety washer **F** is interposed between the flywheel and nut. Proceed as follows to disassemble the parts.

2.3.1 FLYWHEEL

Keep the flywheel in place by means of a special universal device **A**. Unscrew the nut that blocks the flywheel to the motor shaft. Screw the special extractor **B** (code 1480210.000) into the internal thread of the flywheel and extract it by tightening the central screw that presses onto the motor shaft. During this process, the flywheel is kept in place by using a simple flat spanner.



Blocking the flywheel with the universal tool.



Decoupling the flywheel from the motor shaft by means of extractor B (code 1480210.000)



Note: the GB version is provided with an extra mass which must be removed before disassembling the flywheel. In order to do this, heat the two screws and then remove them.

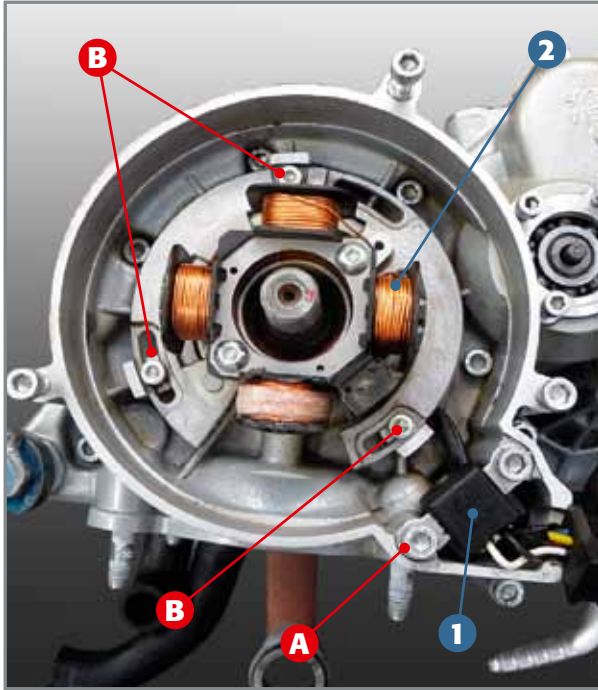

Stator 1 and pick-up 2 assembly.

2.3.2 PICK-UP AND STATOR

Loosen the two screws **A** and the three screws **B** that fasten pick-up **1** and stator **2**, respectively, to the engine casing. Then remove the pick-up and stator assembly.



The seven screws that couple the internal cover of the clutch to the casing.

2.4 CLUTCH UNIT

You must remove the transmission control lever and start-up lever to access the clutch unit. Loosen the seven screws shown in the picture that couple the internal cover of the clutch **A** to the casing.

The clutch unit consists of the components shown in the picture below.

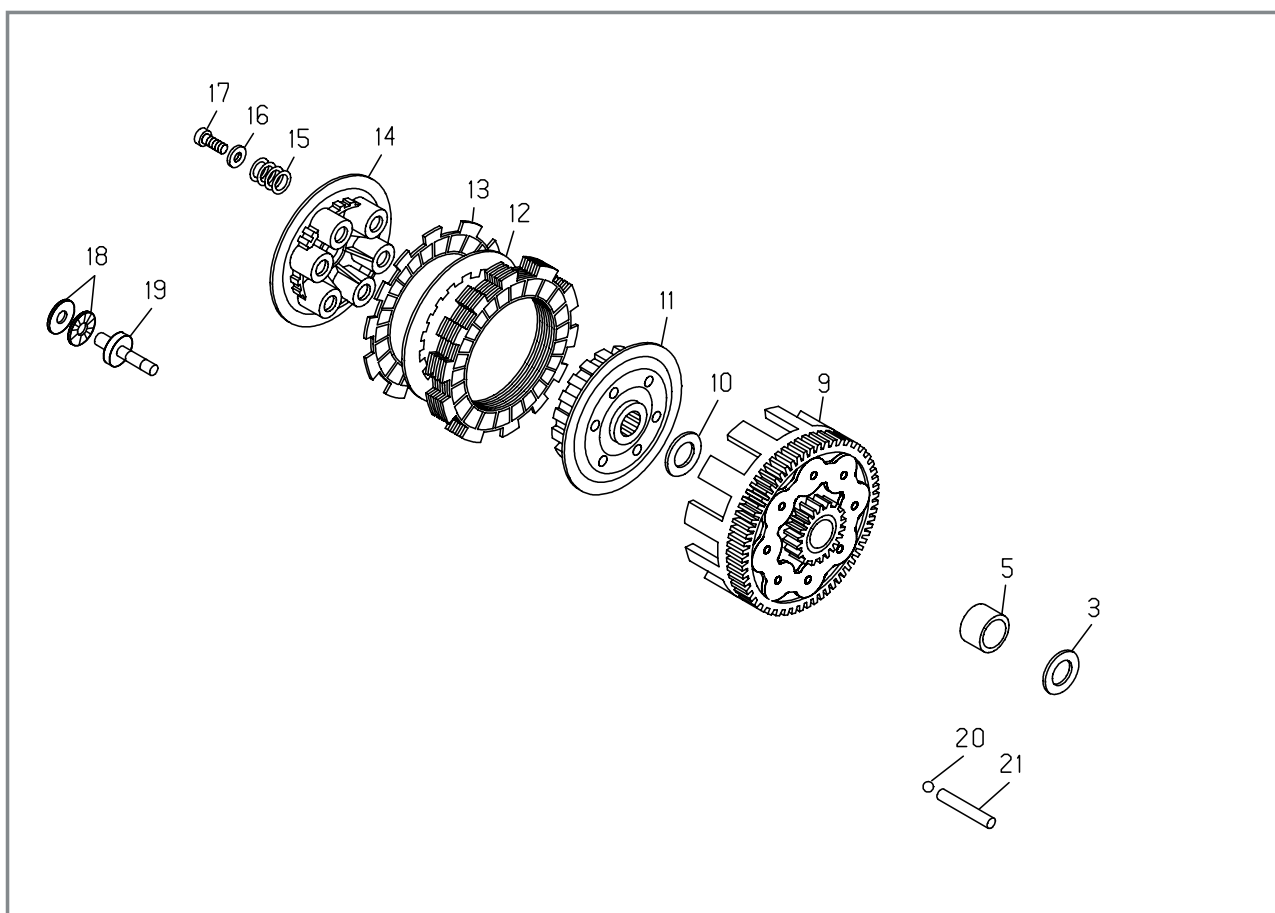

CLUTCH UNIT: MAIN COMPONENTS.

- 3) Washer 20x35x1;
- 5) Bushing;
- 9) Clutch bell;
- 10) Special washer;
- 11) Clutch drum;
- 12) Steel disc (No. 5);
- 13) Friction disc (No. 6);
- 14) Pressure plate cap;
- 15) Spring (No. 6);
- 16) Washer 6x18 (No. 6);
- 17) Screw 6x16 (No. 6);
- 18) Thrust bearing cage 15x18x2;
- 19) Pressure plate;
- 20) Ball;
- 21) Clutch control rod.

To remove this, unthread the clutch control rod **21** and bend it to the right of the engine for the ball **20** to come out.

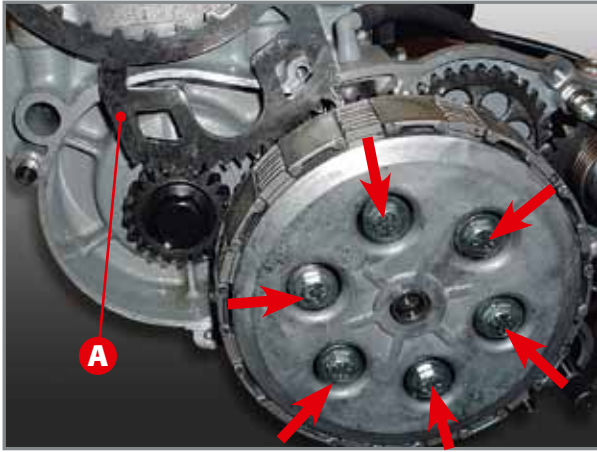

Disassembling the fastening screws of the pressure plate cap to release it from the friction bell.



Opening the flaps of the safety washer.

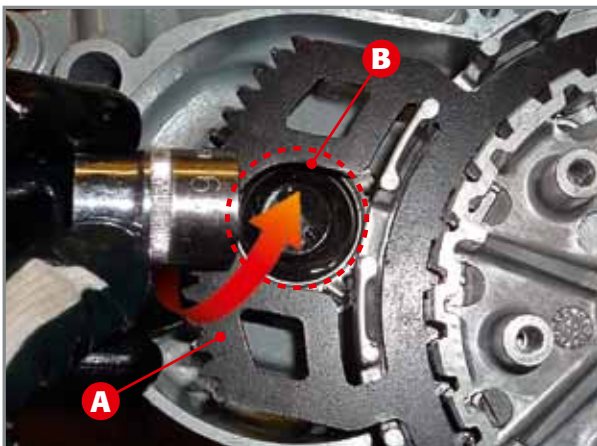

Applying the socket spanner into the opening of the special tool.



Disassembling the nut that blocks the clutch bell to the primary shaft.

- 2.4** Whilst keeping the clutch unit blocked in place by means of the special primary tool **A** (code 008.14.000.0.0), loosen the six screws in order to release the pressure plate cap from the clutch bell. Remove the springs and washers, the pressure plate cap, the thrust bearing unit and the eleven clutch discs.

Insert the special primary tool **A** ensuring its internal teeth engage with those on the drum and then push it until it reaches the drum's stop limit. Open the two flaps of the washer with a chisel or similar tool.

Disassemble the nut that blocks the clutch bell to the primary shaft as follows. Whilst keeping the special primary tool **A** in the position described above, turn the clutch bell so that the opening **B** overlaps the screw of the primary pinion. Insert a socket spanner (size 19) into the opening and engage it with the hexagonal head screw below.

Whilst keeping the socket spanner pressed firmly in place, unscrew the relative nut.

2.5 PRIMARY GEAR

The clutch bell must be in its housing for the primary gear to be disassembled. You must remove the internal cover of the clutch to access the primary gear. This procedure is described in paragraph 2.4.

Use the special primary tool **A** (code 007.14.000.0.0) to loosen the screw that fastens the primary gear 1 to the motor shaft.



Disassembling the screw that blocks the primary gear to the motor shaft.

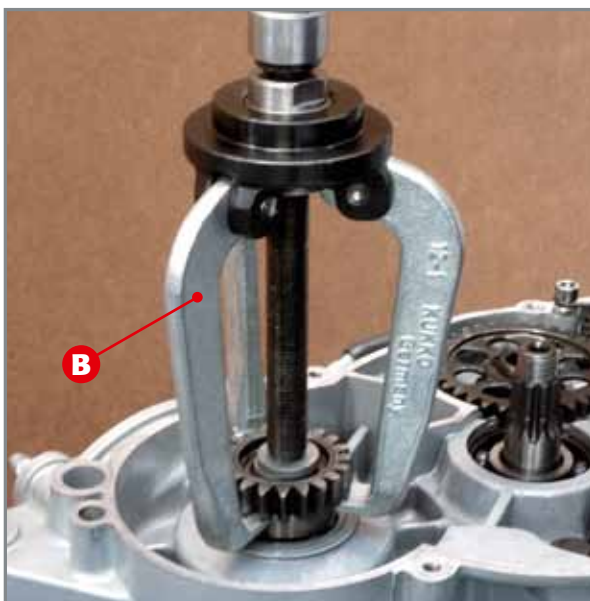

Disassembling the primary gear in a 125 cc engine.



Disassembling the primary gear in 200 cc, 250 cc and 290 cc engines.



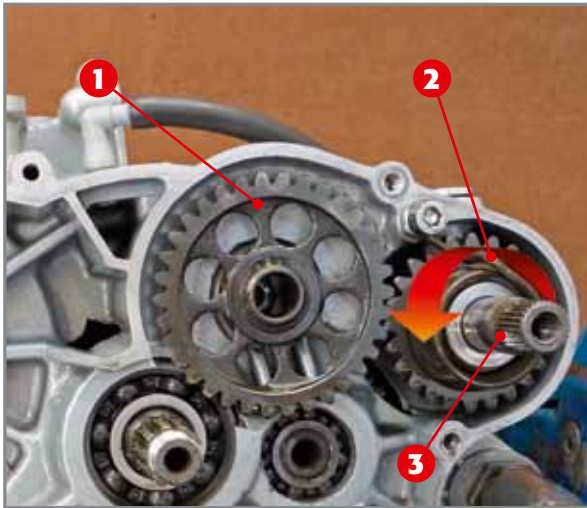

Idler wheel of the start-up device.

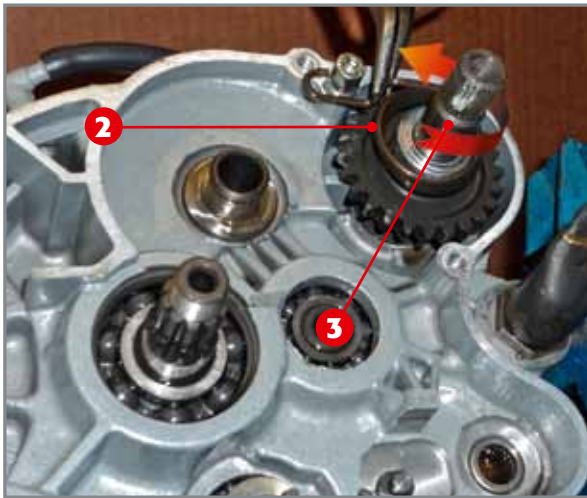

Disassembling the spring and the ignition shaft.

2.6 START-UP DEVICE

To remove the start-up device you must remove the Seeger ring of the driven gear **1** and the specific shim washer. Then extract the driven gear and the relative roller cage.

Release spring **2** by turning it anti-clockwise and remove the complete ignition shaft **3**.

2.7 GEARBOX UNIT

The gearbox unit consists of the control and gear unit. The control is in turn split into internal and external controls. The external control consists of a control lever **1** and assembly of components **7, 14** and **15**, which are found in the casing on the side of the clutch, whereas the internal control consists of components **18, 25, 26, 27, 28** and **29** and is found inside the two casings together with the gears.

GEARBOX CONTROL UNIT: MAIN COMPONENTS.

- 1) Start-up lever;
- 7) Complete gear shaft;
- 14) Screw 6x30;
- 15) Gear stop cam;
- 18) Desmodromic device;
- 25) 27) 29) Fork;
- 26) 28) Fork pin.

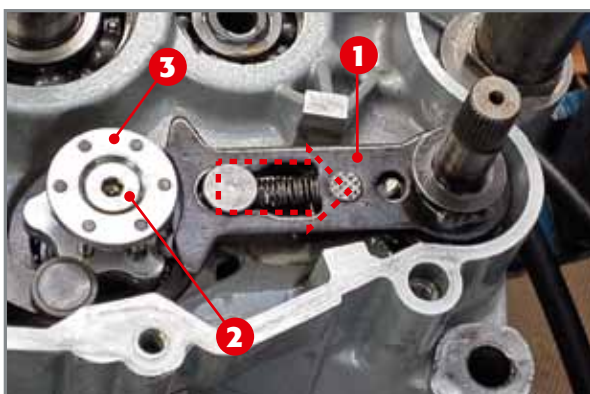
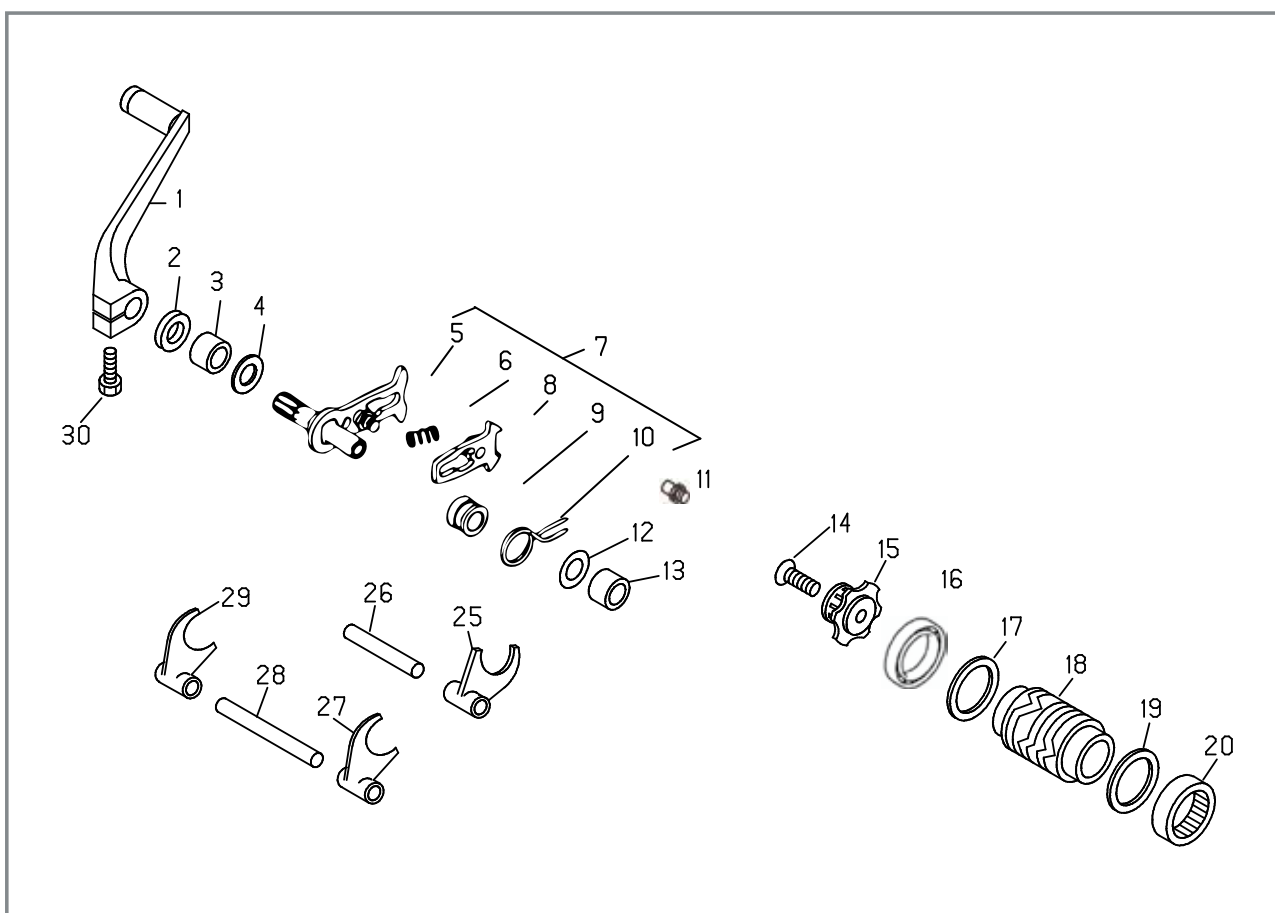

Gear lever and stop cam assembly.

2.7.1 EXTERNAL TRANSMISSION CONTROL

Remove the complete transmission control shaft **1** whilst keeping the spring compressed.

Loosen screw **2** and remove the stop cam **3**.



Decoupling the casings.

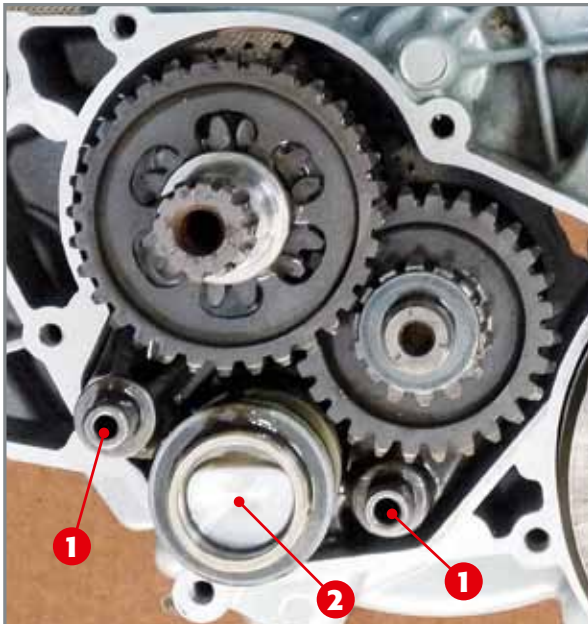

Forks, desmodromic control and gears.

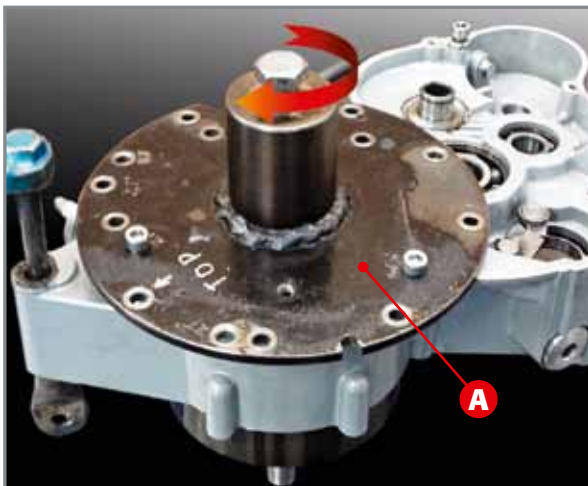

Disassembling the motor shaft.

2.7.2 INTERNAL TRANSMISSION CONTROL AND TRANSMISSION GEARS

The internal transmission control is enclosed inside the two engine casings. To access this, you must remove the eleven screws that couple the two engine casings, then decouple these with the use of the special tool **A** (code 01.00042.000).

Tool **A** must be mounted onto the right casing so as to cover the flywheel housing and fastened to the three threaded holes of the flywheel cover.

Then tighten the upper screw on the tool, whilst holding the motor shaft still (e.g. by holding the connecting rod), until the casings are completely decoupled from each other.

Unthread the two fork pins **1** as much as is needed to decouple them from their respective housing. Turn the pin-fork assembly outwards, remove the desmodromic device **2**, then the shaft-fork assembly. Remove the complete gear unit whilst paying attention to the shim washers.

2.8 MOTOR SHAFT

Mount tool **A** (code 01.00042.000) onto the left casing so as to cover the primary gear housing, fastening it to the three threaded holes of the right casing.

Then tighten the upper screw on the tool, until the motor shaft is completely unthreaded.



2.9 BEARINGS AND OIL SEALS

Remove all oil seals which will be replaced during re-assembly. It is recommended to extract all bearings while hot by placing the casings in an oven at a temperature of 150 °C for about twenty minutes, thereby allowing the bearings to be easily unthreaded. The bearings can also be extracted when cold by using appropriate universal tools. To do so, it is recommended to place the half-casings onto a flat, wooden surface that is big enough to provide ample support and guarantee surface integrity.

Check the wear-and-tear state of the bearings and replace them if any loosening or blockage is noticed.

To insert the bearings once again, insert the half-casings in an oven at 150 °C for approximately twenty minutes. Cold bearings enter their housing very easily. If the bearings are not firmly blocked once they cool, they will probably rotate in their housing the next time they become hot and in such an instance the half-casings must be replaced.

Attention!

before placing the crankcase in the oven, remove all rubber and plastic parts.



ASSEMBLING AND TESTING THE ENGINE

Before reassembling the engine you must perform a number of fundamental tests to guarantee that the engine functions properly.

Hereunder are the main steps and checks.

Before reassembling the parts, grease the oil seals and oil all the bearings.

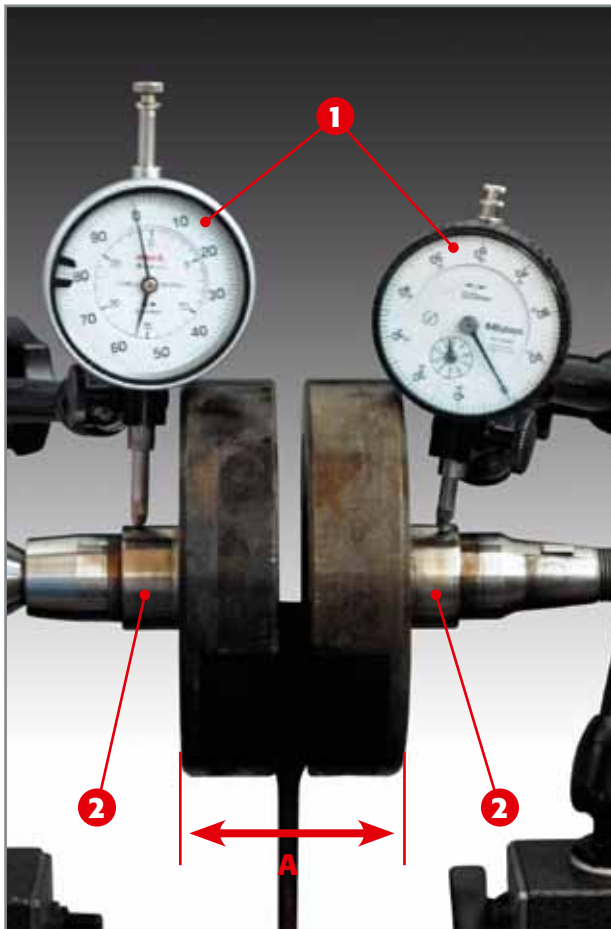

Verifying alignment and torque of each half-shaft.

3.1 TESTING THE MOTOR SHAFT AND CONNECTING ROD

Firstly verify the wear-and-tear state of the coupled surfaces.

Test the misalignment of the axes of the half-shafts by placing the motor shaft between two tailstocks or similar tools and verify the maximum variation in one revolution by means of comparators **1** being placed on the coupled surfaces with the main bearings **2**.

Limit value allowed: 0.08 mm.

Should a difference be noticed in the readings of the two half-shafts, this will be due to the torque of the shaft itself.

Limit value allowed in the difference: 0.03 mm.

Moreover, verify any axial loosening between the head of the connecting rod and the internal part of the half-shafts.

Recommended loosening: 0.39 to 0.72 mm.

Verify distance A between the two external surfaces of the half-shafts that must be **62 mm: +0.05 to -0.15 mm.**



Heating the bearing.

3.2 MOUNTING THE COMPLETE MOTOR SHAFT

The complete motor shaft is first coupled with the left casing. To do so, you must heat the main bearing and the area around it. Continue heating until the motor shaft is inserted into the bearing with minimal hindrance.

Before starting the heating process it is recommended to grease the oil seal found on the outer side of the casing.

Attention!

Be careful not to deteriorate the oil seal during heating.

3.3 GEARBOX UNIT: TESTING AND REASSEMBLING

As seen in paragraph 1.7, the gearbox unit consists of the control and the gearbox itself. The control is in turn split into internal and external controls.

Hereunder are the tests and reassembly procedures of such units to the engine.

3.3.1 TESTING THE TOOTHED WHEELS AND SHAFTS

Perform the following inspections on all toothed wheels:

- verify the wear-and-tear of the sliding surfaces;
- verify there are no cracks and abnormal wear-and-tear on the sides of the teeth **A**;
- verify that the engagement parts **B** of the toothed wheels are not chipped or rounded;
- verify that the areas **C** that make contact with the forks are not particularly worn.

Moreover, verify that the shafts supporting the toothed wheels do not present any signs of seizing or wear-and-tear.

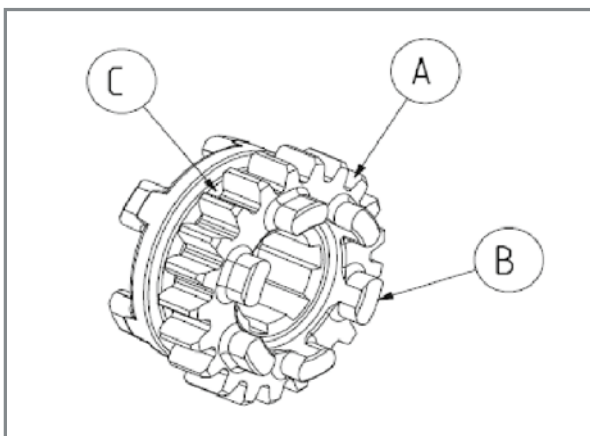

Verifications to be performed on the toothed wheels

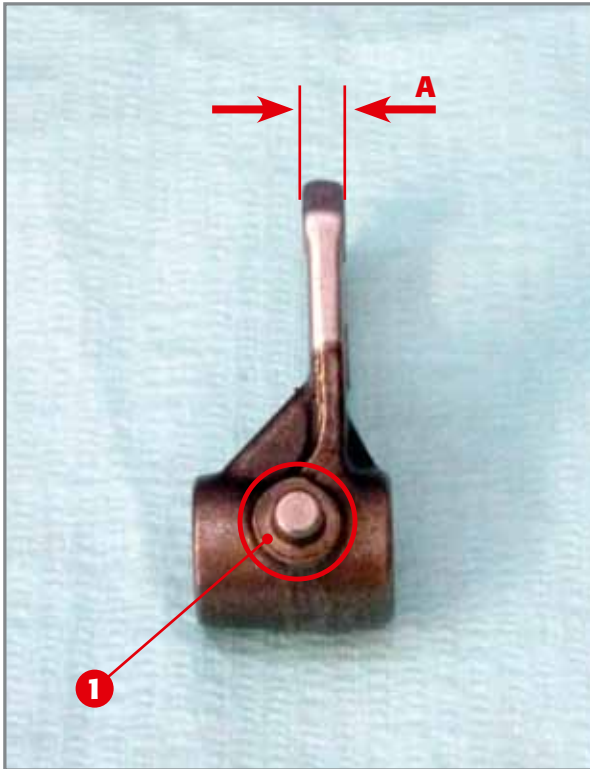

Testing the wear-and-tear of the forks.

3.3.2 TESTING THE FORKS, FORK PINS AND DESMODROMIC DEVICE

Verify that the guide pins 1, which engage in the desmodromic control, do not present any signs of seizing or abnormal wear-and-tear and that distance A between the external surfaces of the fork is not less than the below-mentioned minimum.

Minimum acceptable distance: 4.4 mm.

Verify that the fork pins onto which the forks slide, are not particularly worn or corroded. Verify that the desmodromic control device does not have any corroded and/or worn areas, especially the grooves in which the guide pins of the forks are engaged.

3.3.3 ASSEMBLING THE INTERNAL TRANSMISSION CONTROL

Assemble the gearbox according to the exploded view hereunder, externally from the engine after having verified the wear-and-tear state of the washers and six shim washers.

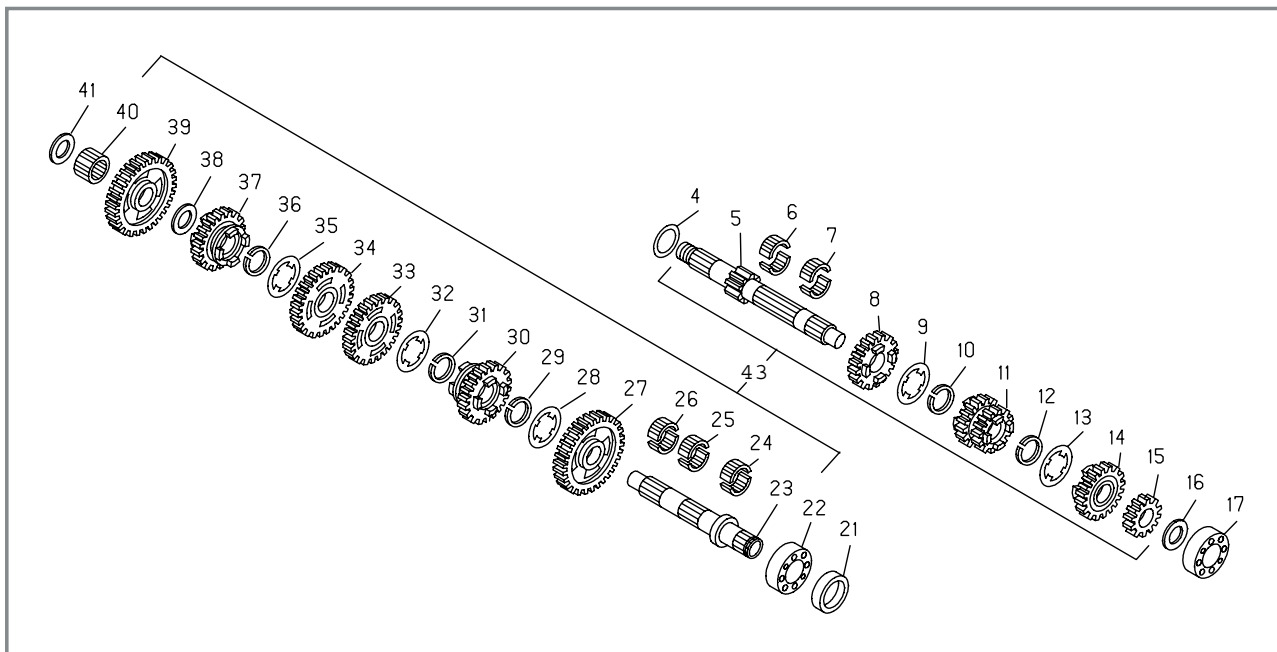

GEARBOX EXPLODED VIEW:

4) Shim washer 20x30x0.5;
 5) Primary shaft;
 6) 7) Roller assembly 16x21x10;
 8) 5vp gear;
 9) Slotted washer;
 10) Seeger 19sw;
 11) 3 / 4vp gear;
 12) Seeger 19sw;
 13) Slotted washer;
 14) 6vp gear;
 15) 2vp gear;
 16) Washer thickness 15x25;

20) Seeger 20e;
 21) Oil seal ring;
 23) Secondary shaft;
 24) 25) 26) Roller cage 18x22x10;
 27) 2vs gear;
 28) Slotted washer;
 29) Seeger 20sw;
 30) 6vs gear;
 31) Seeger 20sw;
 32) Slotted washer;
 33) 3vs gear;
 34) 4vs gear;

35) Slotted washer;
 36) Seeger 20sw;
 37) 5vs gear;
 38) Shim washer 18x27x0.8;
 39) 1vs gear;
 40) Assembly 18x22x10;
 41) Washer thickness 15x25.



Inserting the gear in the left casing .

Insert both primary and secondary units, simultaneously, in the respective housing in the left casing.
 Remember to heavily oil the gears and the shafts that support them.
 It is recommended to verify that all components slide perfectly.





Turning the fork-pin assembly outwards and inserting the desmodromic control device.

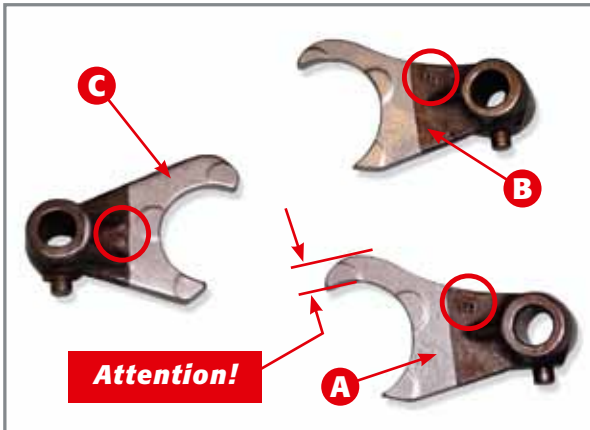

Symbols marked on forks.

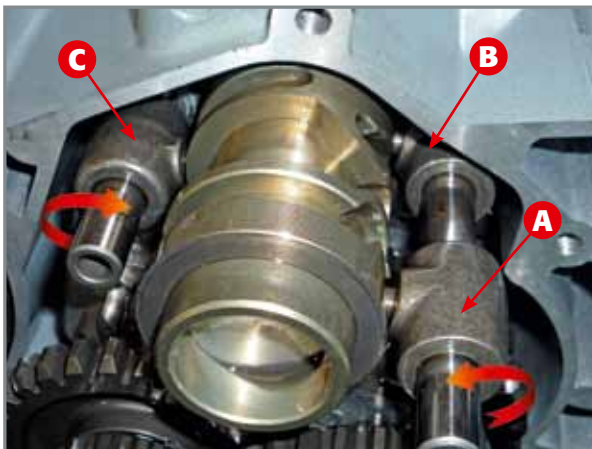

Turning the fork-pin assembly inwards and inserting the fork pins into their respective housing. Inserting the fork guide pins 2 into the slots of the desmodromic device.

Insert the gear, then mount the fork-fork pin assembly, whilst ensuring to first insert the fork into the path of the specific gears. Then turn the fork-pin assembly outwards for the bolts to remain in the casing and not enter their housing.

CAUTION!

Each fork is marked with a symbol that must face the casing. The forks must be applied according to the mark indicated in the images. The upper part of fork "A" is higher than fork "B".

Insert the desmodromic control **1** and turn the fork-pin assembly inwards for the fork pins to enter their respective housing in the casing. For this to occur, the guide pins **2** on the forks must engage with the slots on the desmodromic control.

To verify that all operations pertaining to the reassembly of the gear to the casing function properly you must simply ensure that the toothed wheels turn freely.



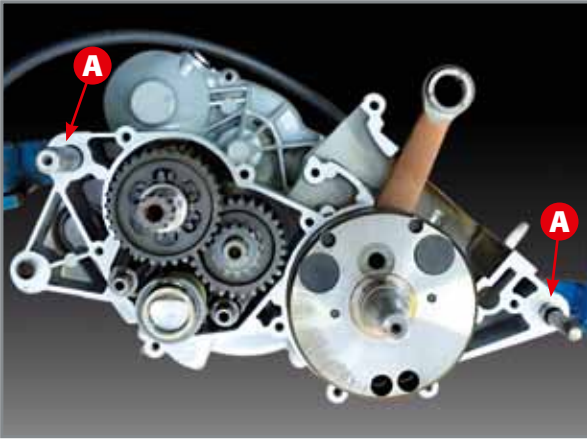

3.4 CLOSING THE ENGINE CASING

Insert two centring bushes A and replace the gasket with a new one. Once the seal is replaced with a new one, heat the main bearing and the area around it on the right casing. Continue heating until the casing enters the motor shaft with minimal hindrance.

Before starting the heating process it is recommended to grease the oil seal found on the outer side of the half-casing.

ATTENTION!

Be careful not to deteriorate the oil seal while heating the bearing

Press the right half-casing towards the left half, ensuring that the shafts, bolts and pins on the casings are inserted into their respective housing and the half-casing is positioned correctly. To facilitate the progressive approach and alignment of the two half-casings, you can use two screws placed diametrically opposite, then tightened gradually. If the casings do not remain in their correct position, do not tighten further but loosen the screws and set the casings back into their correct position.

Ensure that the two casings fit perfectly then mount and tighten the recessed hexagonal head screws (M6x50), whose tightening torque must be 10Nm. It is recommended to tighten the screws in a cross-wise pattern.

Then carefully cut the excess parts of the seal in the cylinder area and intake pipe.

Give a few blows to the end-parts of the motor shaft with a rubber hammer in direction of the axes so as to release any residual stress on the casings caused by the heating process.

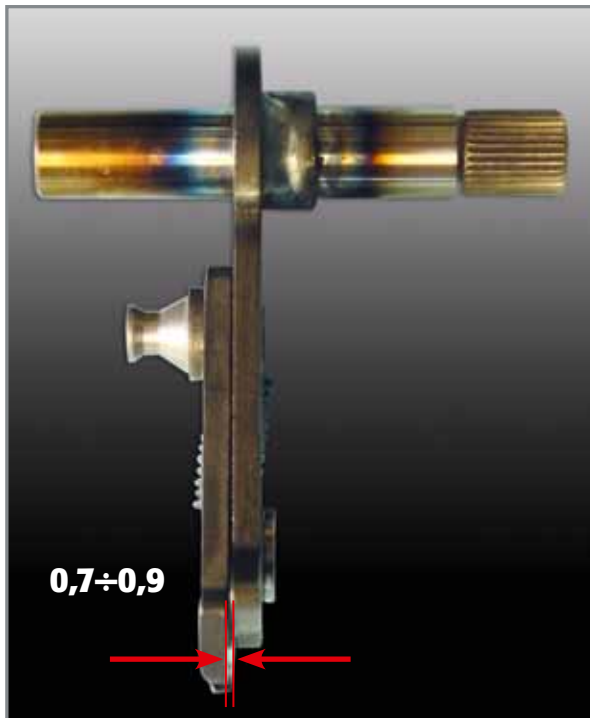

Distanza ammissibile tra albero e ventaglio.

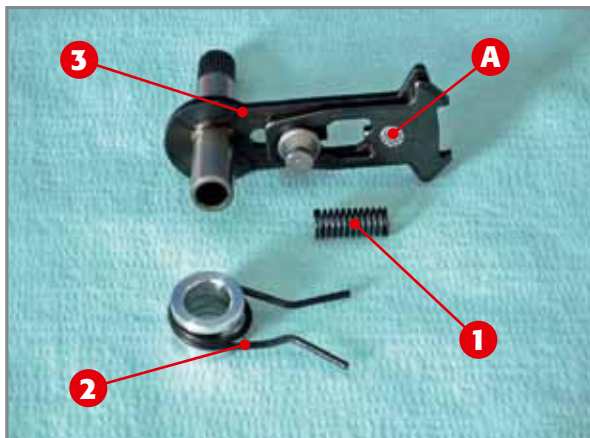

COMPLETE CONTROL SHAFT:

- 1) Pawl spring;
- 2) Spring return transmission control;
- 3) Control shaft;
- A) Area pertaining to the spring return pin.

3.5 EXTERNAL TRANSMISSION CONTROL

Before reassembling the external transmission control you should check the wear-and-tear state of the device. With regards to the stop cam, simply ensure that there is no abnormal wear-and-tear and/or seizing, whereas the gear shaft requires more elaborate verification.

3.5.1 TESTING THE COMPLETE GEAR SHAFT

With the device completed, verify the distance between the mobile pawl and the control shaft falls between 0.70 and 0.90 mm. If the measurement exceeds this, you must replace the mobile pawl.

To replace the mobile pawl you must remove the pawl spring **1** and the return spring of the transmission control **2**. Drill a hole in zone **A** with a 5 mm tip for the return spring pin in which it is riveted until it is disassembled.

Then rest the new mobile pawl onto the control shaft **3**, insert the new spring return pin and rivet the excess part of the pin. Re-mount the pawl spring and the transmission control spring return.

3.5.2 ASSEMBLING THE EXTERNAL TRANSMISSION CONTROL

While keeping the stopping device **1** moved, position the stop cam **2** on the protruding end-part of the desmodromic control **3**, for opening **A**, which is in the lower part of the cam, to engage with pin **B**, which is found on the protruding end-part of the desmodromic control.

Then mount the TSPCE fastening screw M6x30 between the stop cam and the desmodromic control, after placing the medium resistant thread stoppers: tighten to 11Nm.

Insert the transmission control shaft into its housing applying two specific thrust washers at the two ends of the small shaft.

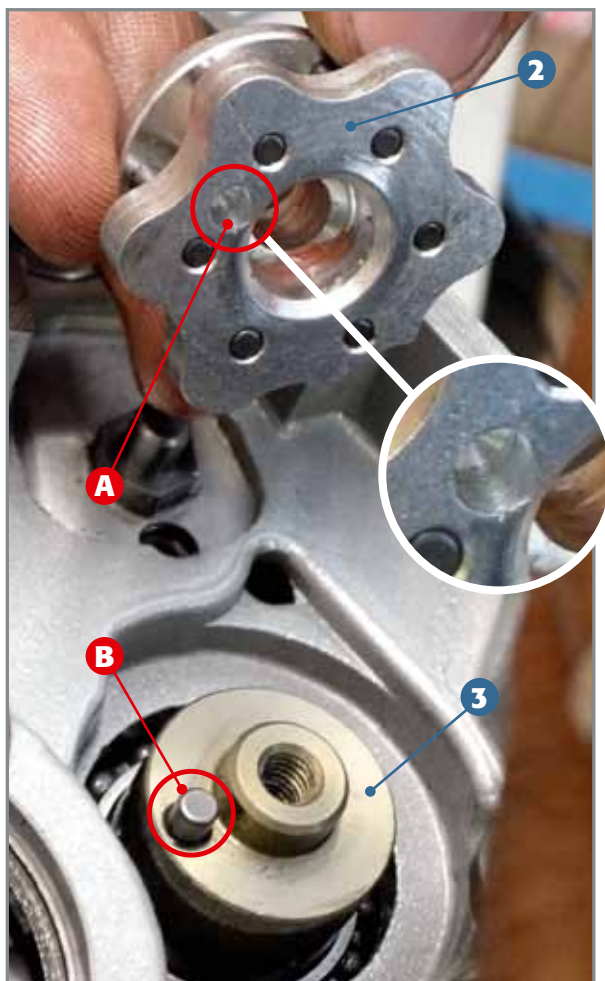

Positioning the stop cam onto the desmodromic device.



Verifying whether the gearbox unit functions properly.

Should you wish to test the entire gearbox unit and ensure it functions properly, temporarily couple the external control lever and simulate a gear shifting operation by lifting and lowering the control lever. If no abnormal blockage occurs, the entire device is functioning correctly.

Please note that if the unit is operated without oil, the device will be noisier than usual.



3.6 START-UP DEVICE

Before reassembling the start-up device you must perform some important verifications.

3.6.1 TESTING THE IGNITION SHAFT AND THE ASSEMBLY

To disassemble all components of the ignition shaft you must remove the spring return lever **11** and spacer **14**. Open the Seeger **23**, which allows you to remove all the other components.

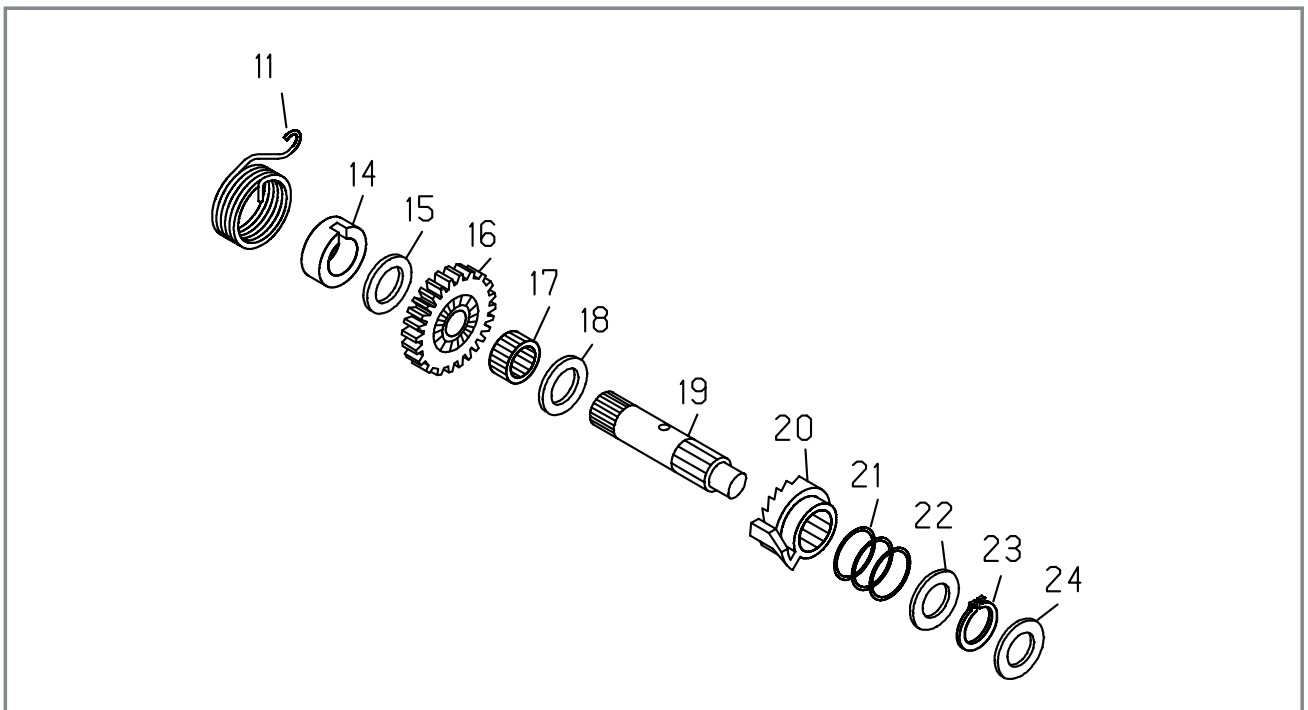

EXPLODED VIEW OF THE COMPLETE IGNITION SHAFT:

- 11) Spring return lever;
- 14) Spacer;
- 15) Washer-spacer;
- 16) Start-up gear;
- 17) Cage 16x20x10;
- 18) Washer-spacer 16x25;
- 19) Ignition shaft;
- 20) Ignition sleeve;
- 21) Sleeve spring;
- 22) Shim washer 20x30x0.5;
- 23) Seeger 20e;
- 24) Washer-spacer 15x25

Verify that the sides of the teeth of the start-up gear **16** do not present any signs of seizing or particular superficial wear-and-tear and that the front teeth (on the side of sleeve **20**) do not have any cracks. If so, replace the component.

Verify that the front teeth of sleeve **20** are not cracked and that the spring **21** exerts enough pressure onto the sleeve for wheel **16** to be driven by sleeve **20**.

Moreover, verify that all the washers and shim washers are not abnormally or excessively worn. If so, replace them. Verify that spring **11** is not cracked or abnormally deformed. Should it fail to bring the external start-up lever back to its idle position, replace it.

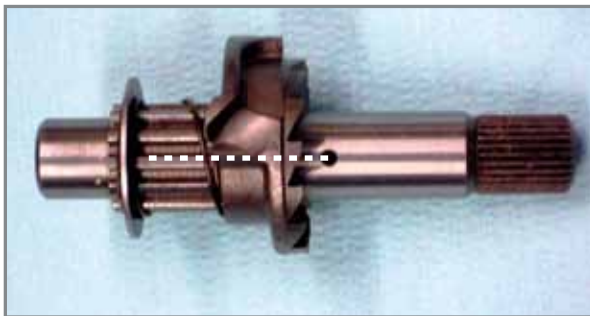

Positioning the sleeve onto the spindle.

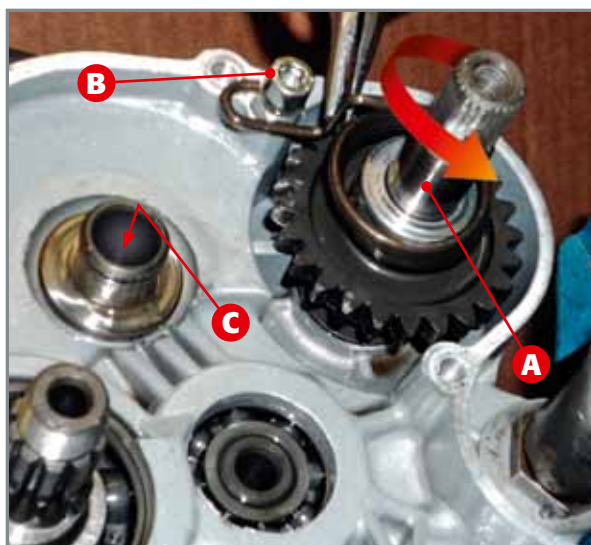

Coupling of the complete ignition shaft to the casing.



Start-up device assembly coupled with the casing.

3.6.1 To reassemble this, insert Seeger **23**, shim washer **22**, spring **21** and sleeve **20** in such a way that the opening that will block spring **11**, is aligned with the left border of the ramp on the sleeve.

Then insert the shim washer **18**, cage **17**, gear **16**, shim washer **15**, spring **11** and spacer **14**.

3.6.2 MOUNTING THE START-UP DEVICE

Insert the complete ignition shaft **A** into the relative housing whilst keeping the spline facing outwards.

Turn the shaft anti-clockwise until the stop limit is reached and then hook the spring return lever to the cylindrical head screw **B**. If this screw (M6x20) has been disassembled, tighten it with a torque of 10Nm. If the idler gear pin **C** has been disassembled or replaced, tighten the relative Allen screw (M8x20) with a torque of 23Nm.

Insert the idler gear into the relative pin and the washer-spacer 18x27 and close the assembly with the Seeger (18e). Lubricate the assembly with transmission oil and mount the external lever temporarily to then simulate ignition so as to verify that no abnormal blockage occurs.



3.7 PRIMARY GEAR AND CLUTCH UNIT

After having verified that the teeth of the primary gear do not have any dents and/or abnormal wear-and-tear, insert the primary gear into the conical part of the motor shaft (left side) straight after having thoroughly degreased the part of the shaft in question and the opening on the gear. Then insert the fastening screw as far as possible.

The fastening screw between the motor shaft and the primary gear must have a torque of 120Nm. This can be implemented once the clutch bell is inserted by using the special primary tool **A** (code 007.14.000.0.0).

3.7.1 TESTING THE CLUTCH BELL AND REPLACING THE SILENT-BLOCK

Before remounting the clutch bell, check that the sides of the teeth **A**, which pertain to primary transmission and **B**, which pertains to the seizing process with the start-up idler gear, do not have any superficial corrosion or are abnormally worn.

Carefully analyse the teeth **C**, with which the conductor discs engage, to ensure they are not cracked or worn.

If any damage is caused, replace the components.

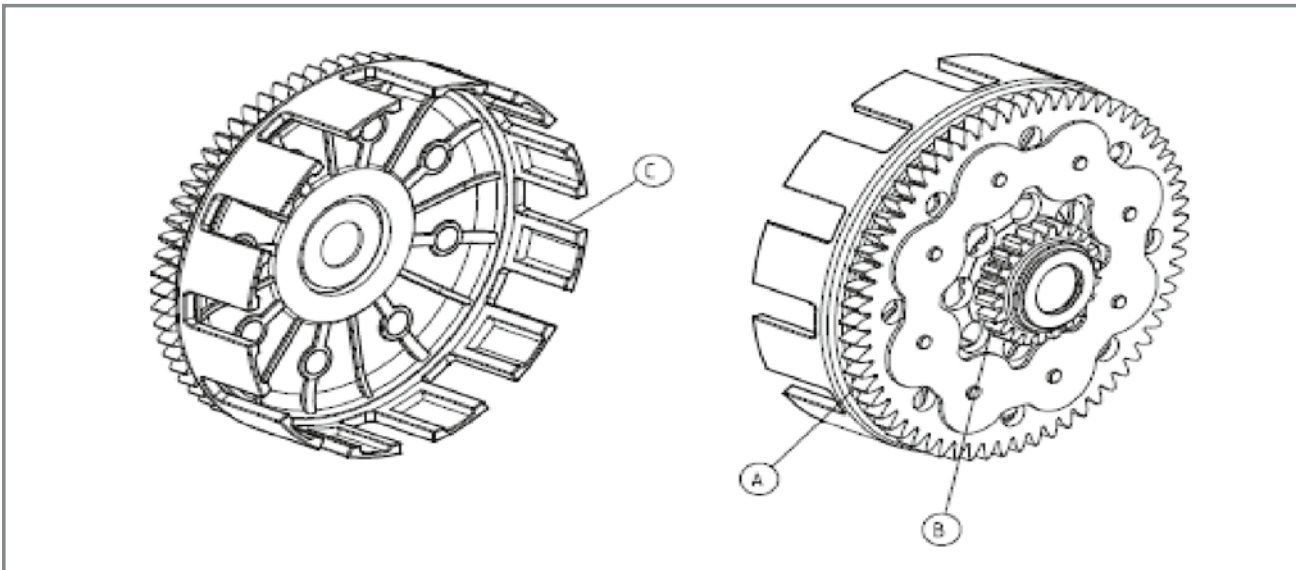

CLUTCH BELL:

- A) Teeth engaged with the primary gear;
- B) Teeth engaged with the start-up idler gear;
- C) Teeth engaged with the conductor discs.

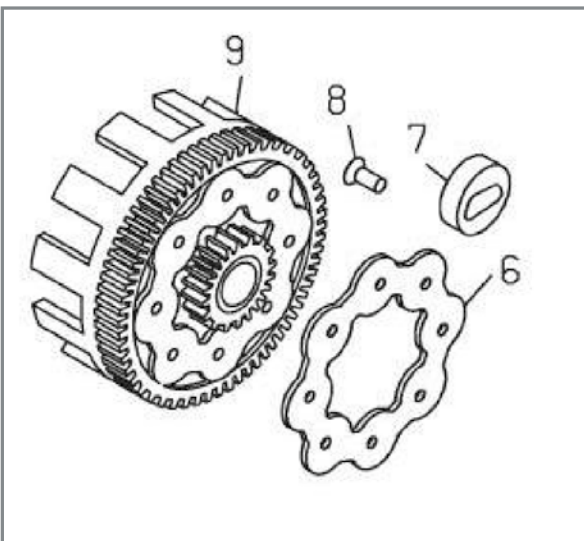

Exploded view of the clutch bell. Verifying the silent-blocks 7.

Verify the wear-and-tear state of the silent-blocks **7** as follows. Whilst keeping the toothed wheel with the wider diameter in place, make the clutch bell **9** turn. Should there be loosening between the two components, the silent-blocks must be replaced.

The silent-blocks are replaced by piercing the riveted part of rivet **8** with a 5 mm tip. Place the bell in such a way for the retaining disc to be mounted from above, and then couple the new silent-blocks to the clutch bell in the relative housing.

Bring the retaining disc towards the bell and insert the rivets (5x15) and rivet them.

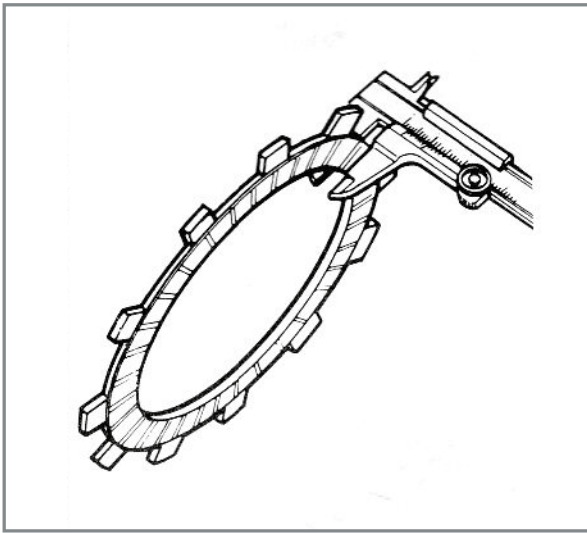

Minimum distance between two opposite inserts.

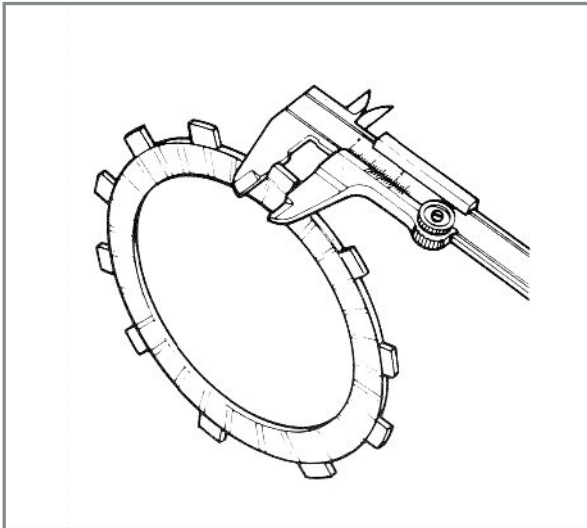

Minimum tooth thickness of the driving discs.

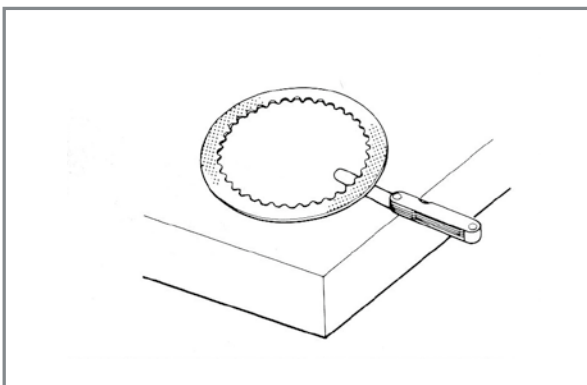

Measuring the distortion of the driven discs.

3.7.2 TESTING THE CLUTCH DISCS

The clutch discs are divided into driving and driven elements: six driving discs and five driven discs.

Both sides of the driving discs have cork inserts that become worn due to the sliding movement with the driven discs.

You must verify that the thickness between two inserts placed on opposite sides of each driving disc is not less than the minimum value set at: **minimum distance between two opposite inserts: 2.5 mm.**

Another value you must verify is the tooth thickness of each driving disc and this must not be less than the minimum value set at: **minimum tooth thickness of the driving discs: 13.5 mm.**

Moreover, verify the distortion of the driven discs. This is implemented by resting the driven discs onto a perfectly flat surface and with the use of a feeler blade verify that the gap between the disc and surface does not exceed: **acceptable distortion of the driven discs: 0.10 mm.**



Measuring the length of the clutch springs.

3.7.3 TESTING THE SPRINGS

To ensure that the pressure between the clutch discs is correct, you must verify the wear-and-tear state of the springs. The minimum acceptable length is: minimum length of the clutch springs: **33.3 mm (new springs 33.8 mm)**.

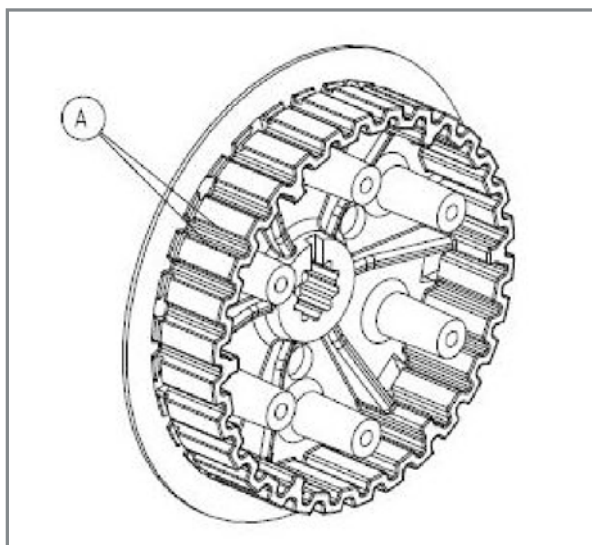

Testing the teeth of the clutch drum.

3.7.4 TESTING THE CLUTCH DRUM

The clutch drum is engaged with the driven clutch discs by means of teeth **A**: verify that the teeth do not present any seizing or abnormal wear-and-tear. If so, replace the drum.



Tightening the nut that blocks the clutch bell to the primary shaft.

3.8 ASSEMBLING THE CLUTCH

Insert washer **1** 20x35x1 and bushing **2** on the primary shaft then mount the clutch bell **3**. Ensure that the radial loosening between the clutch bell and bushing falls between:

radial loosening of the clutch bell bushing: 0.01 to 0.11 mm

Then insert a new special washer **4**, clutch drum **5**, the new safety washer **6** and the nut **7**.

The nut must be tightened to a torque of 70Nm whilst keeping the clutch bell-primary gear assembly blocked in place by means of the special primary tool **A** (code 007.14.000.0.0). Paragraph 2.4 contains the description of its correct use.

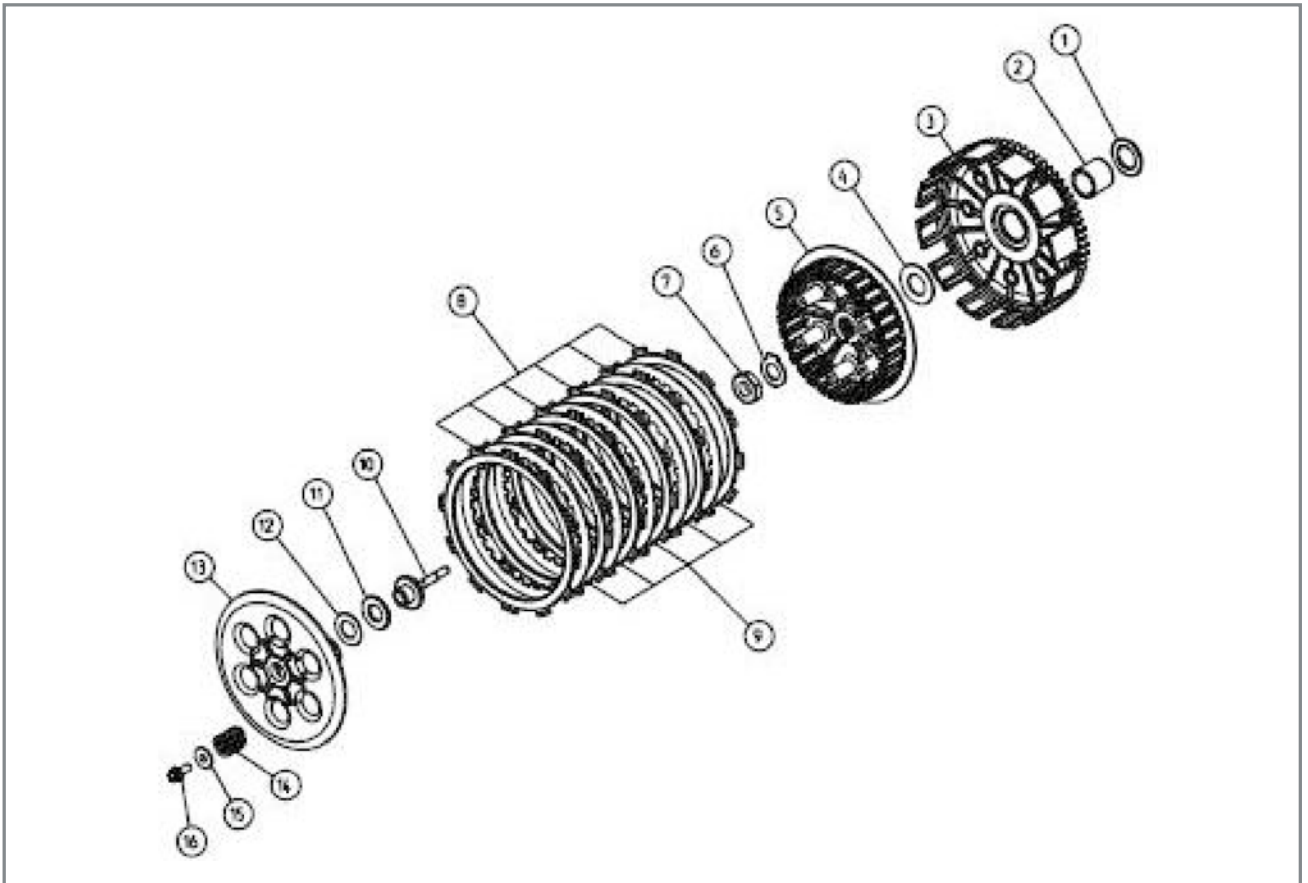

CLUTCH EXPLODED VIEW:

- 1) Washer 20x35x1;
- 2) Bushing;
- 3) Clutch bell;
- 4) Special washer;
- 5) Clutch drum;
- 6) Safety washer;
- 7) Nut;
- 8) Driving discs;
- 9) Driven discs;
- 10) Pressure plate;
- 11) Thrust bearing;
- 12) Special washer;
- 13) Pressure plate cap;
- 14) Spring;
- 15) Washer 6x18;
- 16) Screw M6x16

3.8 Once this is tightened well, fold the two flaps on the safety washer for them to rest onto the nut.

Grease the clutch discs with new transmission oil and insert the clutch discs set, alternating a driving disc and a driven disc.

Enter the longer part of the thrust plate **10** into the housing on the primary shaft and the thrust bearing **11** together with the special washer **12**.

Close the clutch bell with the pressure plate cap **13**, insert the springs into the respective housing on the cap and then the washers **15** 6x18 and the screws **16** M6x16 that must be tightened to 10Nm in a cross-wise pattern, whilst keeping the clutch assembly blocked in place by means of the special primary tool (code 007.14.000.0.0).

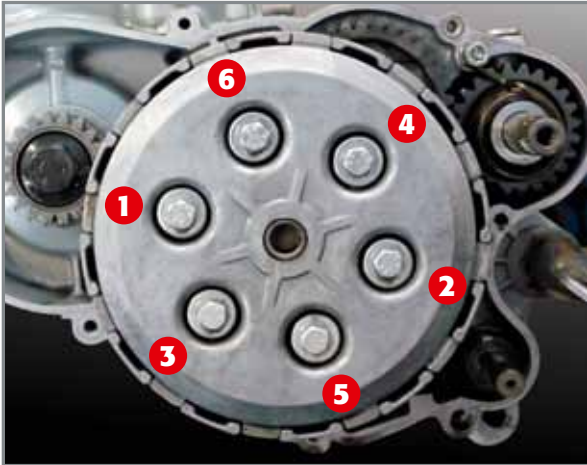

Tightening order of the clutch bell bolts.



Layout of the screws on the internal cover of the clutch.

3.9 INTERNAL COVER OF THE CLUTCH

Couple a new seal with the left casing after inserting centering pins and the internal cover of the clutch.

The layout of the bolts is shown in the picture and these must be tightened to a torque of 10Nm by following a cross-wise pattern as shown in the picture below.

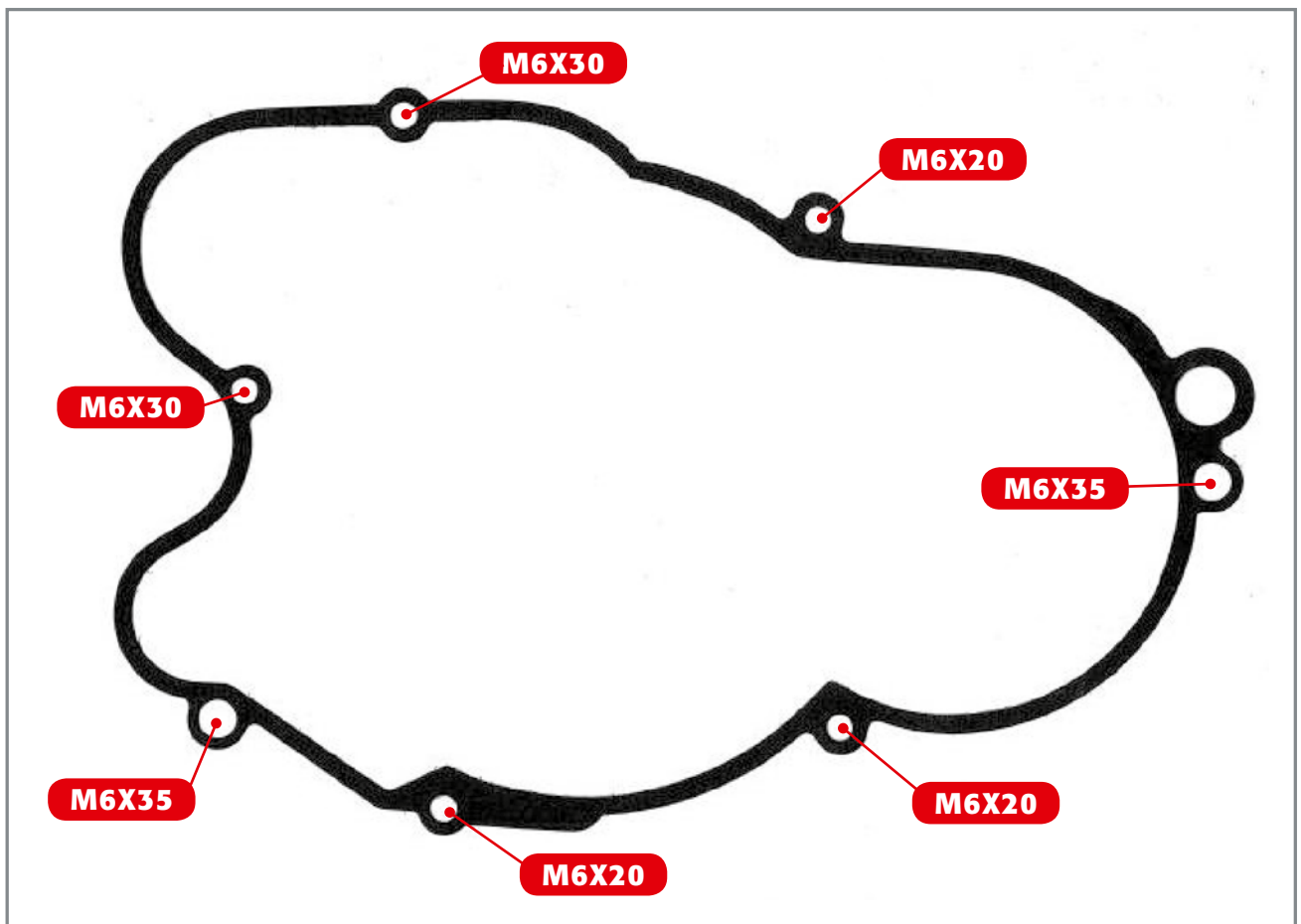

Tightening order of the casing cover bolts.

3.10 IGNITION SYSTEM

Before reassembling the ignition system, you should carry out the following inspection.

3.10.1 TESTING THE IGNITION STATOR

The stator winding must be inspected while the temperature of the component is approximately 20 °C.

The inspection may also be performed with the generator coupled to the engine.

Disconnect the 12-way black connector between the generator and CDI and with the use of a multimeter, verify that the resistances read between the terminals shown below fall within the prescribed range:

black-white (pick-up): 320 ohm \pm 15%

red-blue (condenser): 300 ohm \pm 15 %

yellow-brown (services): 0.45 ohm \pm 20 %



Verifying stator winding functionality.

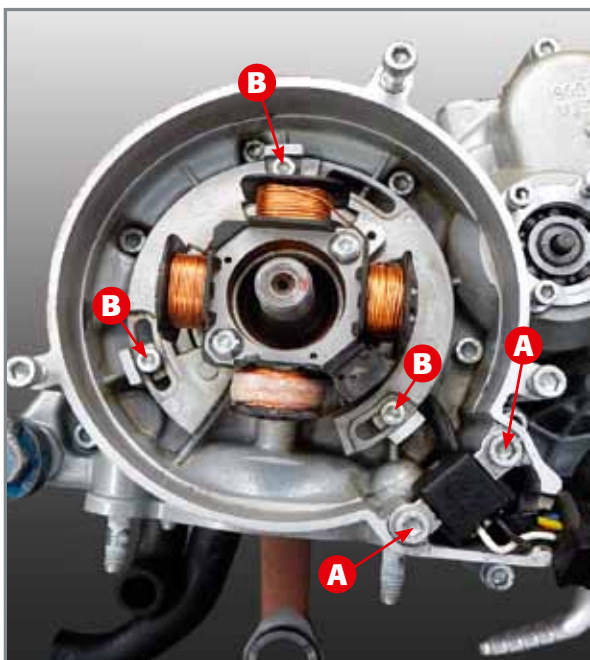

Stator 1 and pick-up 2 assembly.

3.10.2 STATOR AND PICK-UP WINDING

Insert the stator winding and pick-up into the respective housing whilst being careful not to crush the cables between the stator and pick-up.

Apply medium resistant thread stoppers to bolts **A** and **B** and then tighten both bolts **A** to a torque of 8Nm and the three bolts **B** to a torque of 6Nm.

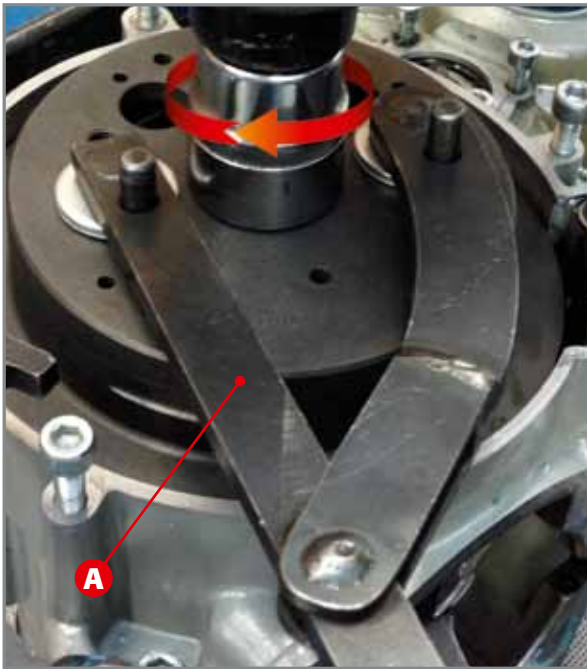

Mounting the flywheel onto the motor shaft.



3.10.3 FLYWHEEL

After having thoroughly degreased the conical surfaces, insert the flywheel into its compartment on the right side of the engine, ensuring that the opening on the flywheel enters the Woodruff key. Insert the special washer and the nut that fastens the flywheel to the motor shaft.

Keep the flywheel in place with the use of a special universal device **A** and tighten the nut that blocks the flywheel onto the motor shaft at a torque of 140Nm.

The GB version is provided with an extra mass. This must be applied to the flywheel once again and fixed by the two specific screws which must be tightened at a torque of 20Nm.

3.11 THERMAL UNIT

Before assembling the thermal unit you must perform thorough verifications on the cylinder, piston, piston pin, piston rings and head as described below.

3.11.1 TESTING THE PISTON, PISTON PIN AND PISTON RINGS

Remove the carbon deposits from the piston crown and wash the entire plunger with a special degreasing product. Do not use pointed or sharp tools for the cleaning process. Then carefully analyse the piston, which must have no strains, scratches, cracks or any kind of damage.

Then analyse the external diameter of the plunger - the limit of service is given in the table below, relative to the specific category. The diameter must be measured at X from the bottom of the mantle, perpendicular to the axis of the piston pin.

The category is marked on the piston crown.

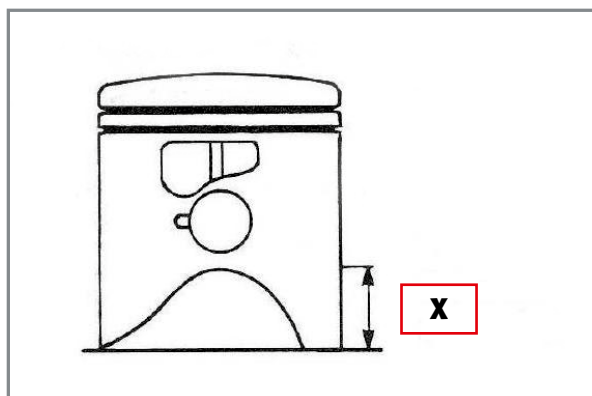

Height at which the external diameter of the piston is measured.

Cubic Capacity [cm ³]	Height X [mm]	Limit of service according to the category			
		A	B	C	D
125	11.5	53.935	53.945	53.955	
200	12	63.935	63.945	63.955	63.965
250	13.5	72.445	72.455	72.465	
290	16	77.950	77.960	77.970	

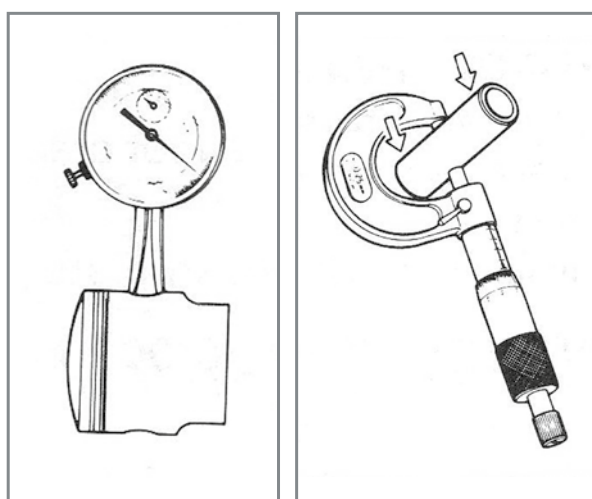

Measuring the piston pin and its housing.

Verify the size of the piston pin and its housing found on the piston. The piston pin must be measured from its extreme ends, which engage with the piston.

Cubic Capacity [cm ³]	Size limit [mm]	
	Piston pin housing	Piston pin
125-200	16.02	15.99
250 - 290	18.02	17.99



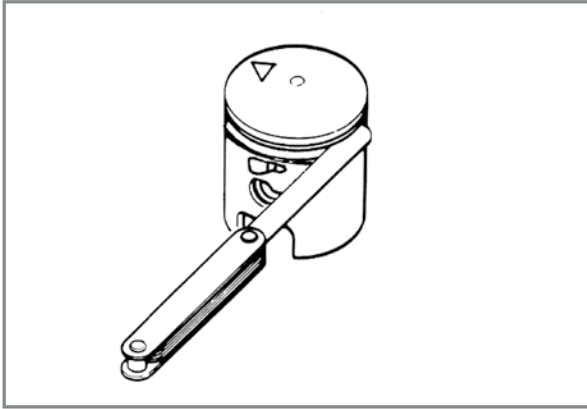

Testing the loosening between the housings and piston rings.



First verification of the piston rings.

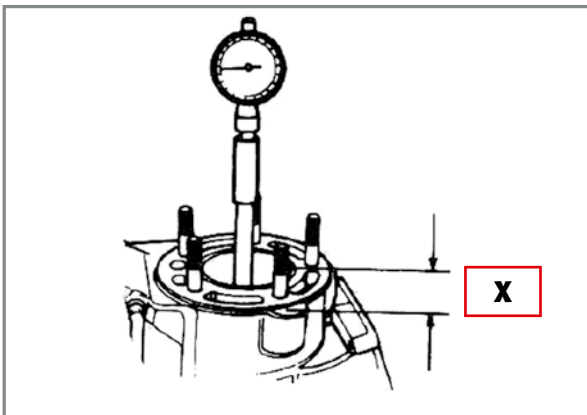

Placing the gauge to measure the bore.

3.11.1 Verify the loosening between the housings and piston rings by placing a caliper in between.

Cubic Capacity [cm ³]	Limit of service [mm]
125	0.18
200	0.18
250	0.14
290	0.14

To verify the wear-and-tear state of the piston rings you must insert the piston ring into the cylinder for its axis to be collinear with the cylinder's axis. Then measure the distance between the two opposite edges.

Cubic Capacity [cm ³]	Limit of service [mm]
125	0.60
200	0.60
250	0.60
290	0.60

3.11.2 TESTING THE CYLINDER AND HEAD

Verify that the bore falls within the limits of service in respect to the category shown in the table below, whilst ensuring to measure it at the distance of **X** from the upper edge of the cylinder itself.

Please note that this measurement is to be taken by placing the bore gauge with its axis perpendicular to the axis of the motor shaft.

Cubic Capacity [cm ³]	Height X [mm]	Limit of service according to the category			
		A	B	C	D
125	10.0	54.005	54.015	54.025	
200	13.0	64.005	64.015	64.025	64.035
250	10	72.515	72.525	72.535	
290	10	78.015	78.025	78.035	

3.11.2 The maximum loosening between the cylinder and the piston must be within the values given in the table below. To evaluate the loosening, you must apply the difference between the diameter on the cylinder and that on the piston at the height of **X** as stipulated in the tables above. Should the difference exceed those stipulated in the table below, replace the piston with another from the same category that is marked on the piston crown.

Cubic Capacity [cm ³]	Loosening limit between the cylinder and piston (worn)			
	A	B	C	D
125	0,06	0,07	0,07	
200	0,07	0,07	0,07	0,07
250	0,07	0,07	0,07	
290	0,06	0,06	0,06	

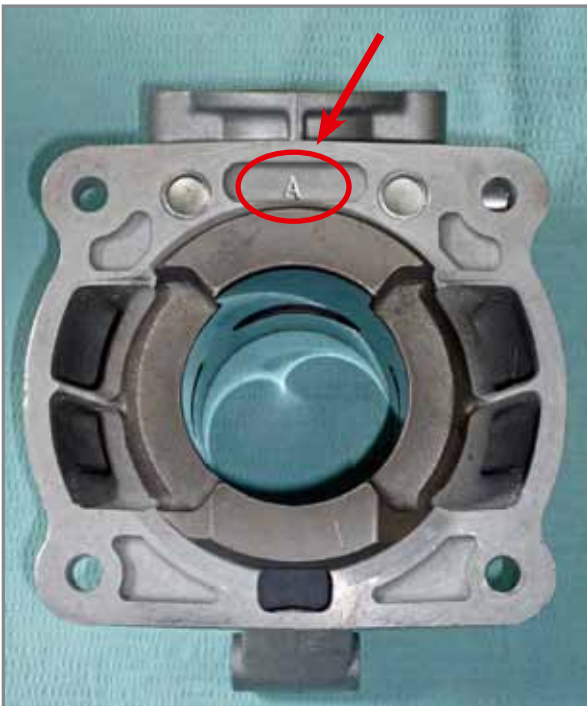

Position of the class marking on the cylinder.

Should the result exceed those stipulated, replace the piston with another from the same category that is marked on the piston crown.

Verify that the cylinder is perfectly smooth. Otherwise, replace the element. The cylinder class is marked on the lower part of the cylinder, on the side of the exhaust manifold.

Verify that the coupling surface between the cylinder and head is flat. This can be carried out by resting the surface of the cylinder onto a smooth surface and verifying that the gap does not exceed 0.05 mm when measured with a caliper.

The same test is performed on the head, where the cylinder and head are coupled.

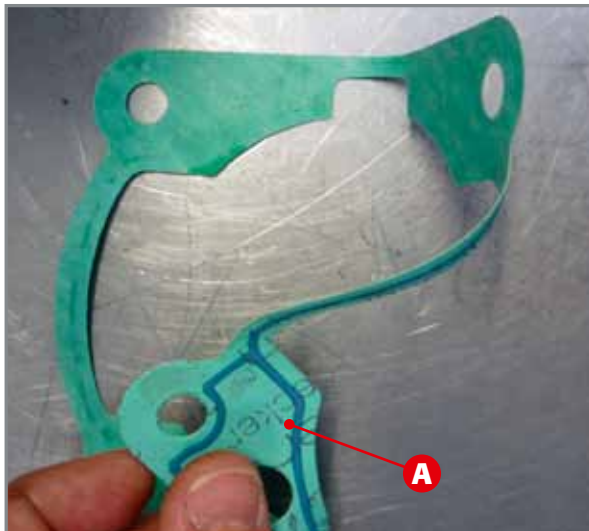

Detail of the paper seal that is to be mounted between the base unit and the cylinder.

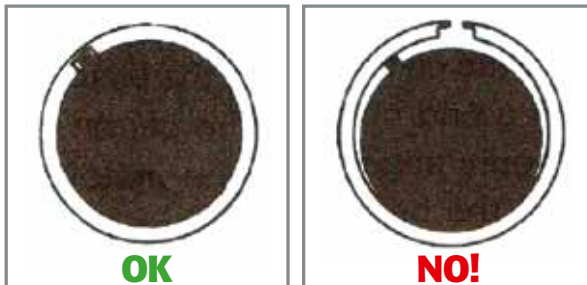

Positioning the piston rings onto the piston.



The letter marked on the piston rings.

3.12 ASSEMBLING THE PISTON, PISTON RING, PISTON PIN, CRANK CASE/CYLINDER GASKET AND CYLINDER

Insert a circlip to retain the piston pin in one of the housings on the sides of the piston by placing the open part of the seeger towards the top or the bottom.

Oil the piston pin and insert in the piston; then couple the piston pin with piston on the opposite side of the circlip, leaving enough space to allow the connecting rod to be couple with the piston.

Insert the roller cage into the connecting rod, place the piston with the arrow facing to the exhaust side .

Insert the second circlip.

Insert the cylinder base gasket on the cylinder and crank cases. The rubber lip A must be facing the crank cases.

To have the correct gasket thickness, read the 3.12.1 par.

First We suggest to use a new gasket with the same thickness as the old one.

Heavily oil the piston with motor oil, then insert the piston rings, the edges of which must face the stop-pin area. The 125cc my'11, 200cc, 250cc, 290cc piston rings, have a letter marked on one side, which will be applied facing the top piston.



Inserting the piston into the cylinder.

- 3.12** Carefully oil all the cylinder with motor oil and insert the piston into the cylinder. Pressing the piston rings with your fingers and push the piston into cylinder. The exhaust port on the cylinder must be facing the front of the engine. Push the cylinder towards the crank cases and tighten the four nuts in criss-cross pattern. The nuts must be tightened at a torque of 23Nm.

3.12.1 THICKNESS CHECK OF CYLINDER/CRANKCASES GASKET

The thickness check of cylinderbase gasket must be do whenever:

- Cylinder is changed
- Piston is changed
- Crankshaft is changed
- Con road
- Crankcases are changed

This check is very important to have a good performance of engine.

The thickness check must be do by special tools. The table shows the special tools in correspondence to Displacement and Model Year.

Displacement [cc]	Model Year	Cod.
125	2009/2010/2011	007 440100 000
125 "Factory"	2010	
200	2009/2010/2011	007 440110 000
250 "GB"	2010/2011	
250	2009/2010/2011	007 440120 000
290	2009/2010/2011	



The position of the tool on the cylinder.



The the tool touches the cylinder and the piston.



The tool touches the cylinder but don't touches the piston: Measure the clearance between piston and tool.



Caso in cui il pistone spinge il piastrino verso l'alto.

3.12.1 The special tools must be use in this way:

- Lean on cylinder the special tool as shows the picture.

- Bring the piston to the TDC; the clearance between tool and piston must be $0 \pm 0,10\text{mm}$. Measure the clearance using the thickness gauge.

If the clearance is $>0,10\text{mm}$, it is necessary reduce the gasket thickness.

If the piston push upward the tool is necessary increase the gasket thickness.

The gaskets have four thickness:

- 0,2mm;
- 0,3mm;
- 0,5mm;
- 1,0mm

It is possible to stack the gaskets.



Seal head with highlighted reference to the mount.

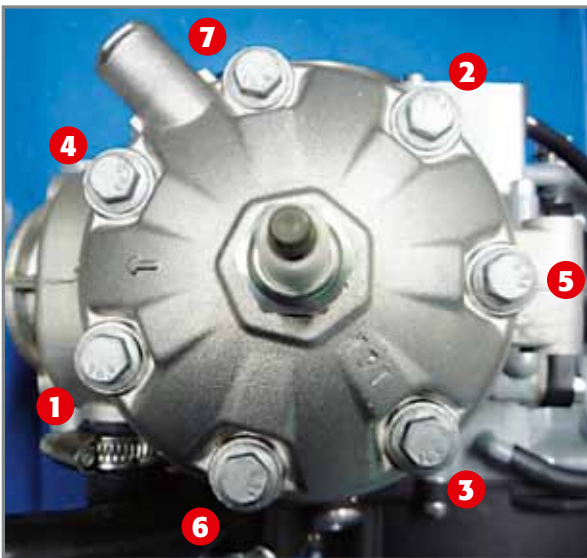

3.13 ASSEMBLING THE HEAD

Turn the flywheel to ensure that the crankshaft functions correctly.

Put grease inside the threaded holes where the head locking screws will be placed. Remove the excessive grease on the surface where the head gasket will be placed.

Place the gasket on the cylinder taking care that the reference label A on the gasket must be placed aligned with exhaust flange.

The reference label on the gasket

Place the O-ring in its seat on the upper external area of combustion chamber and place the combustion chamber into the head cover.

Place the head on the gasket taking care that the arrow printed on the head cover must be pointed towards the exhaust flange.

Place screws (M7x31) in place together with copper washers (7x12x0,5) and screw by hand till they keep head cover in place.

Lock the screws by following 2 times the sequence listed below. Use the following listed torque according to locking sequence:

- First lock 15Nm
- Second lock 22Nm

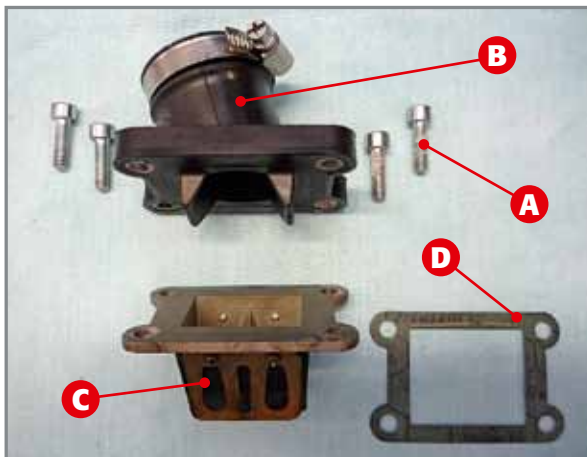

EXPLODED VIEW OF THE INTAKE SYSTEM.

- A) Bolts;
- B) Intake manifold;
- C) Lamella pack;
- D) Seal

3.14 INTAKE SYSTEM

You must also verify the efficiency of the intake system in order to be sure of the established performance. Particular reference is made to the lamella pack as well as the integrity of the intake manifold and seal.

3.14.1 TESTING THE LAMELLA PACK

The lamella pack consists of the support, lamellas and stoppers.

Verify that the lamellas are not broken, cracked or deformed. This test requires you to simply observe the complete pack so as to verify whether there are any gaps between the lamellas and the support. If so, replace the lamellas.

However, it is recommended to replace the entire pack every 40 hours of operation. Do not mount lamellas that are made of a different material than that stipulated.

3.14.2 MOUNTING THE INTAKE SYSTEM

Couple the seal **D**, the complete lamella pack **C** and the intake manifold **B** to the base unit.

Fasten it all by tightening the four bolts **A** with a torque of 7Nm.

3.15 START-UP AND GEAR LEVER

Insert the start-up lever into the specific slotted shaft and place it in such a way that when idle, the foldable part is inserted into the housing on the exhaust manifold. Tighten the bolt M6x16 with a torque of 23Nm after having applied the thread stoppers 100m sp sichel.

Insert the transmission control lever into the specific slotted shaft by placing it in a horizontal position or in the most comfortable position for the user. Tighten the locking screw M6x25 with a torque of 10Nm.



3.16 WATER PUMP UNIT

The pump unit consists of a centrifugal impeller **26** that supports the shaft **21**, which is fastened to the pump gear **20** by means of the roller **22**. The impeller is closed with cover **32** by means of three bolts **33** and sealed with O-ring **27** and oil seal **25**.

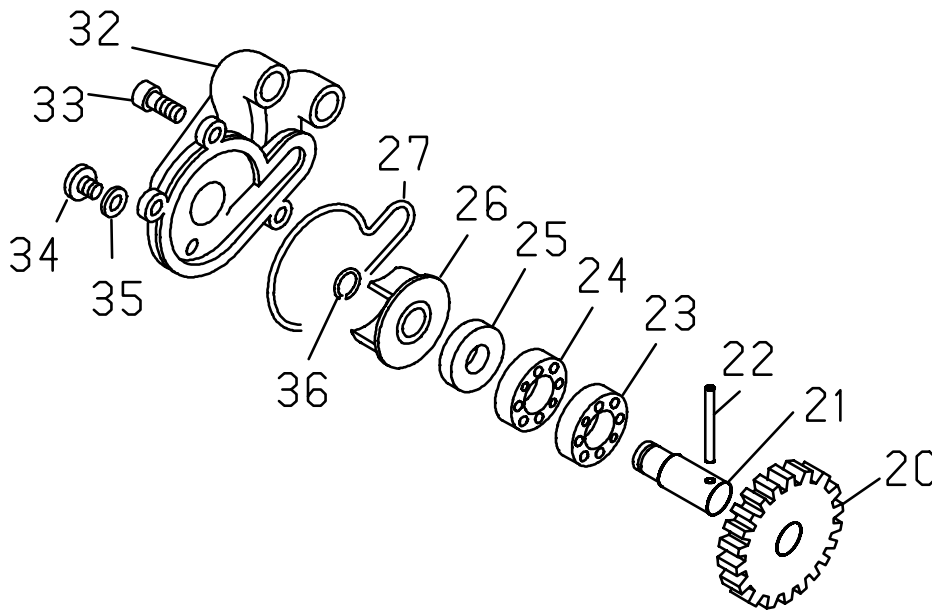

EXPLODED VIEW OF THE PUMP UNIT:

- 20) Pump gear;
- 21) Shaft;
- 22) Roller;
- 23) Bearing 10x22x6;
- 24) Bearing;
- 25) Oil seal 10x18x4;
- 26) Impeller;
- 27) O-ring;
- 32) Cover;
- 33) Screw M5x16;
- 34) Screw M6x8;
- 35) Seal 6x12x1.5;
- 36) Seeger 9e

3.16.1 DISASSEMBLING AND REASSEMBLING THE WATER PUMP

Should it be necessary to intervene on the two bearings or oil seal, you must disassemble the shaft and then the entire clutch casing.

To access the impeller to verify its wear-and-tear state you must remove the pump cover by loosening the three screws that fasten the cover to the internal casing of the clutch. Then open the special snap ring **36** and extract the impeller.

Verify that the front part of the impeller is not damaged. Otherwise, replace the element.

Check the wear-and-tear state of the oil seal and replace it if not intact.

MOUNTING THE ENGINE ON THE VEHICLE AND REPOSITIONING THE COMPONENTS

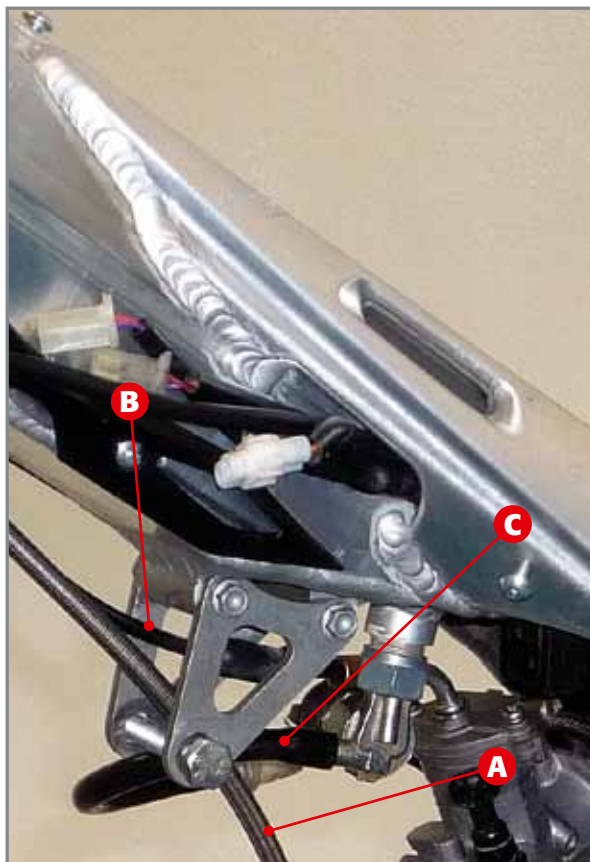

Passing the pipes and cables.

4.1 GENERAL GUIDELINES

Before reassembling the engine onto the vehicle, it is recommended to follow a number of preparatory steps in order to prevent blockage or entanglement occurring due to the cables, pipes or metal clamps.

It is recommended to keep the cables on the right side of the engine unit and place the clamps onto the water sleeves in such a way so as to facilitate the tightening process.

Ensure that the vapour vents pass through the specific metal cable duct.

The frame, the clutch actuator pipe **A** and the accelerator cable **B** must pass between the two upper brackets for the engine to be anchored to the frame.

Ensure that the fuel pipe **C** does not pass between the above-mentioned brackets in order to prevent crushing the pipe when the engine is inserted.





Positioning the pins to anchor the engine to the vehicle.

4.2 COUPLING THE ENGINE TO THE FRAME

Place the engine beneath the vehicle, lift it and insert the following in the same order:
 The lower bolt **A**;
 The upper bolt **B**;
 The swing arm bolt **C**.

*Please note that to facilitate inserting the engine between the two upper brackets, it is recommended to loosen bolts **D**.*

Insert the control box support into the protruding part of the upper bolt, then insert the nut.



Inserting the pinion into the output shaft.



Rotating the chain tensioner



The three screws of the flywheel casing.

4.3 COUPLING THE CLUTCH ACTUATOR, PINION AND FLYWHEEL CASING

Place the clutch actuator in its housing and tighten the four bolts (M5x12) with a torque of 6Nm.

Proceed as follows to insert the pinion onto the output shaft.

Ensure that the chain is channelled into the guide found on the protection block **A** on the swing arm. Insert the pinion into the chain and whilst turning the tensioner **B** downwards, insert the pinion onto the output shaft until it reaches the Seeger mounted onto the shaft. Insert the external Seeger. Let the tensioner go and whilst turning the wheel ensure that no blockage occurs.

Then couple the flywheel casing with the engine by means of the three bolts M6x20 that are to be tightened with a torque of 10Nm.



Detailed control box and cable assembly.

4.4 ELECTRONIC CONTROL BOX

Before inserting the electronic control box into its support, it is recommended to set the multi-pin connector in place and pass the cable that connects the engine to the main system.

Place the multi-pin connector of the control box in such a way for it to enter its relative space in the control box support.

Slide the cable to the main system along the right engine bracket and fasten it with a clamp (refer to the arrow).

Insert the control box in such a way for the housing on the elastic control box to engage with flap **A**. Insert the multi-pin connector well into the control box.

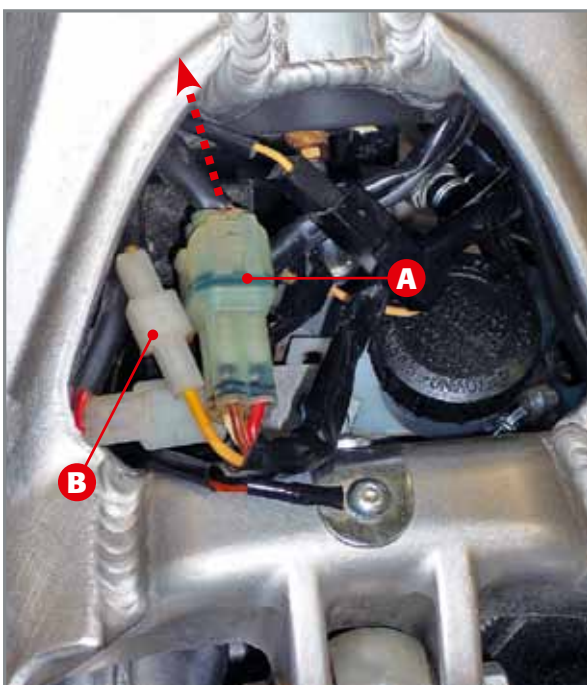

Monopole and quadripole connectors.

4.5 CONNECTING THE ENGINE CABLE TO THE MAIN SYSTEM AND MOUNTING THE REAR MUDGUARD

Before remounting the rear mudguard you must reconnect the engine to the main system by means of the quadripole and monopole connector.

Connect connectors **A** and **B** to the counterparts of the main electrical system and fasten them to the cables with clamps.

Pull the cables forward to the left side of the frame until the connectors enter beneath the frame itself.

Then reassemble the rear mudguard by tightening its bolts with a torque of 5Nm after having connected the relative connector to the back light.

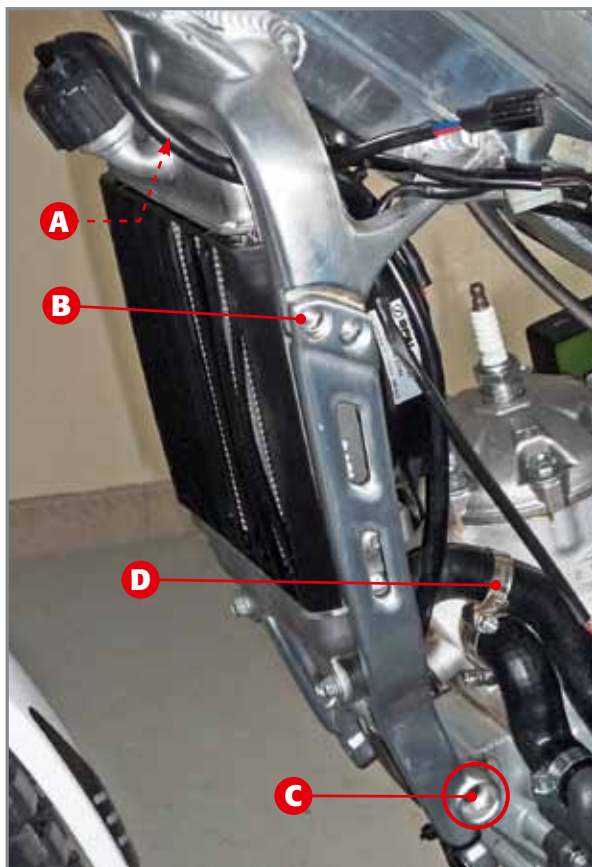

Reassembling the water radiator.



Reassembling the coil and support.

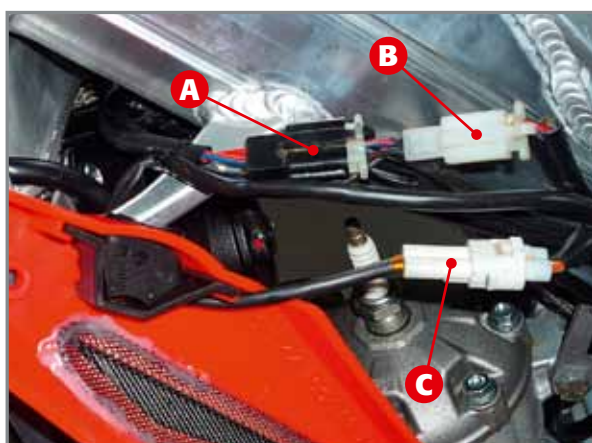

4.6 REMOUNTING THE COMPLETE WATER RADIATOR AND COIL

Insert the upper bolt **A** of the radiator into the special housing found on the frame and insert the four bolts **B** (two on each side), without tightening them well, which fasten the engine brackets to the frame. Then insert the front engine bolt **C**.

Tighten the four bolts **B** (M6x1.25x16) that fasten the engine brackets to the frame with a torque of 10Nm and then the front engine bolt **C** (M10x1.5x127) with a torque of 25Nm.

Then tighten the anchor nuts and bolts between the engine and frame as explained in paragraph 4.2, with the following torque values.

Component	Tightening torque [Nm]
Lower bolt A (10x1,25x100)	30
Upper bolt B (8x1,25x55)	30
Swing arm bolt C (16x1,25x155)	50
Bolts D (6x1x50)	10

Connect the water pipes to the radiator, reposition the metal clamps and tighten.

Reposition the coil with the relative support in its housing found on the radiator, insert the bolt and tighten well.

Reconnect the connectors **A** and **B**, which respectively pertain to the electric fan and the thermal bulb, then connector **C**, which connects the map switch to the main electrical system. Then cover the three connectors with the left side and tighten the two bolts (M5x0.8x8) that fasten it to the frame with a torque of 5Nm.

4.7 ENGINE PROTECTION PLATE

Reposition the engine protection rubber on the plate, bring the assembly close to the engine, insert and tighten the respective bolts.

Bolts **A** must be tightened with a torque of 20Nm and bolts **B** with 30Nm, after having applied the medium resistant thread stoppers.

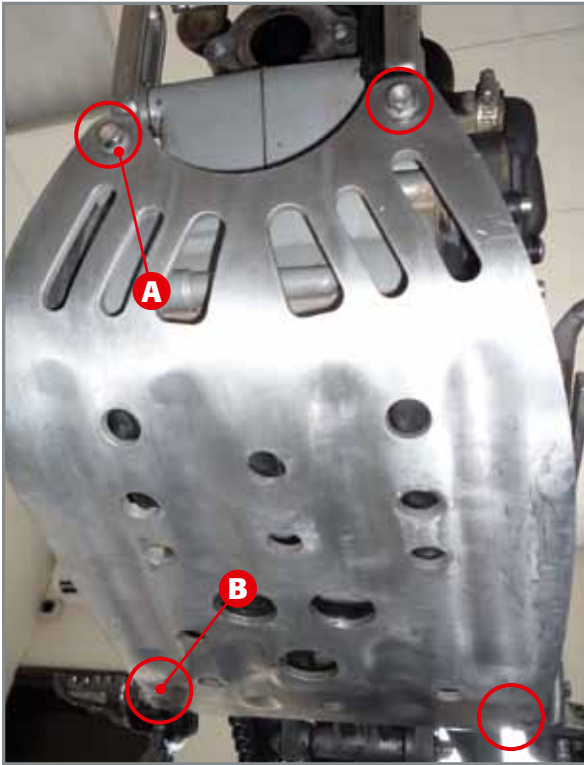

Engine protection plate.

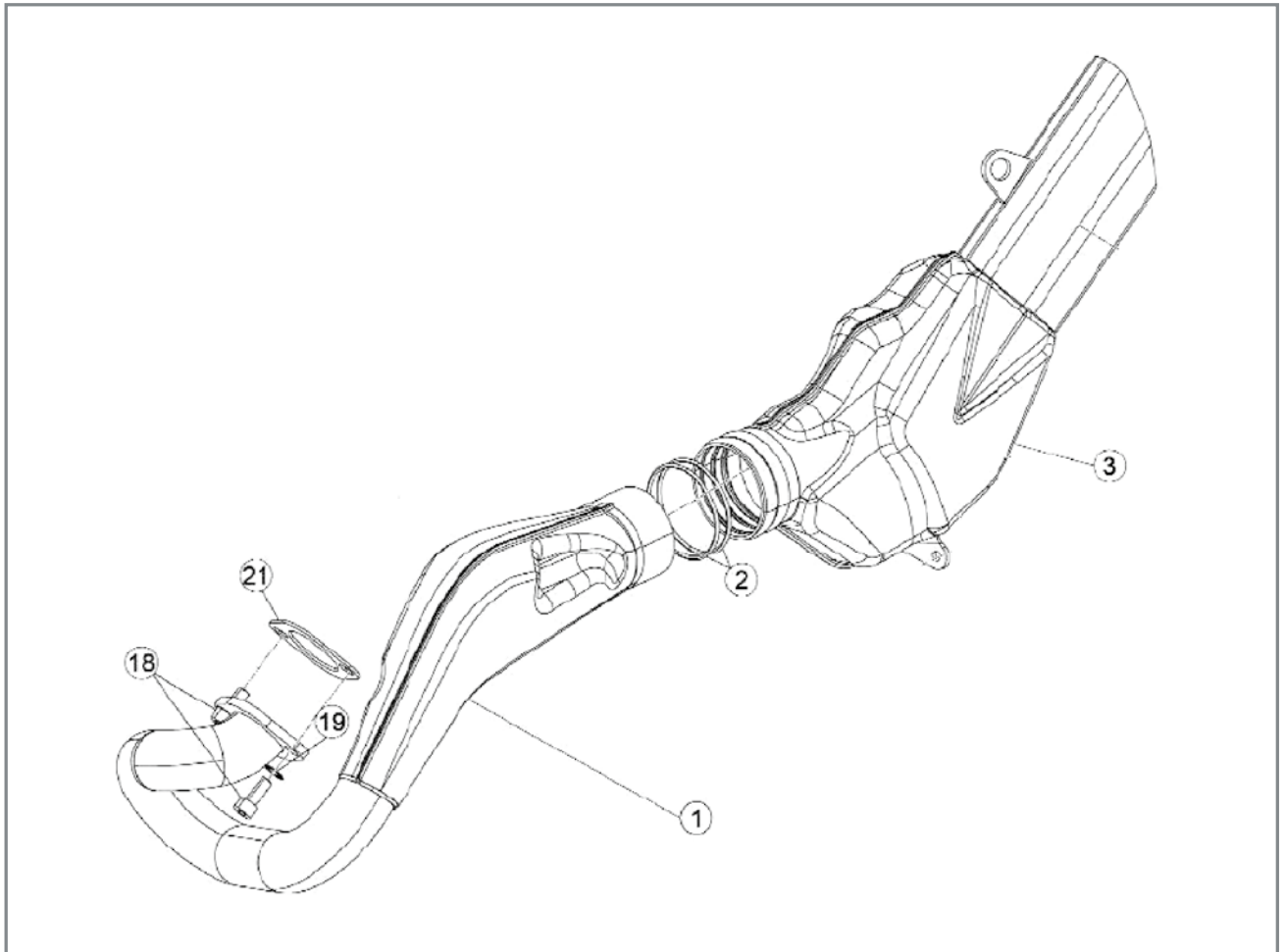

EXHAUST PIPE EXPLODED VIEW:

- 1) Exhaust manifold;
- 2) O-ring;
- 3) Silencer;
- 18) Bolt 8x20;
- 19) Grover washer;
- 21) Seal

4.8 EXHAUST MANIFOLD

Reposition the exhaust manifold 1 onto the vehicle for the two flange openings to be close to the respective openings on the cylinder. Couple the manifold with the silencer 3, interpose the seal 21 between the cylinder and the exhaust manifold and insert bolt 18 (M8x1.25x20) into the opening on the right side of the cylinder. Push the manifold into the silencer whilst paying utmost attention to O-rings 2 so as to ensure they do not get entangled and break.

Insert the second bolt 18 (M8x1.25x20) into the left opening on the manifold flange and tighten the two bolts 18 with a torque of 23Nm.

To facilitate the tightening process, it is recommended to turn the handlebar to either side so as to leave more handling space when using a hexagonal spanner with a spherical head.



TABLE OF TIGHTENING TORQUES OF THE ENGINE COMPONENTS

Fastening	Component	Cl.R.	Pcs.	Thread stoppers	Torque [Nm]
THERMAL UNIT					
Head - Cylinder (head with internal cap)	Special bolt M7x31	12.9	7		20-22
H2O pump cover	Allen screw M5x16	8.8	3		6
	TTLIC Screw M6x8	4.8	1		5
CRANKSHAFT UNIT					
Primary gear screew	Special screw M12x1.25	10.9	1		120
Flywheel-nut	Special nut M16x1.25 ch24	8	1		140
BASE UNIT					
Right casing - Left casing	Allen screw M6x50	8.8	11		10
Casing – Motor shaft reducing ring	Allen screw M5x16	8.8	8		6
Clutch casing - Left casing	Screw M6x20	8.8	3		10
	Screw M6x30	8.8	2		10
	Screw M6x35	8.8	2		10
Cylinder - Casing	Stud bolt M8x46	8.8	4		20-23
*Cylinder - Casing	Stud bolt M8x41	8.8	4		20-23
Special flanged nut	M8 ch10	8	4		20-23
Flywheel cover	Allen screw M6x20	8.8	3		10
Clutch cover	Allen screw M6x20	8.8	4		10
Intake manifold	Allen screw M6x20	8.8	4		7
Oil level cap	M16x1.25	-	1		10
Oil indicator cap	M16x1.5	-	1		-
Oil drain cap with magnet	M16x1.25	-	1		10
IGNITION UNIT					
Pick-up fastening	Allen screw M6x12	8.8	2	Medium resistant thread stoppers	8
Stator fastening	Allen screw M5x12	8.8	3	Medium resistant thread stoppers	6
Start-up idler gear	Allen screw M8x20	8.8	1		23
Start-up lever	Bolt M8x16 ch10	8.8	1	Medium resistant thread stoppers	23
Spring return start-up lever	Allen screw M6x20	8.8	1		10
	Nut M6x3.5 ch10	04	1		10
Sleeve	Special bolt M12x1.25	-	1		10
Spark plug	N7YCC M14x1.25	-	1		25-30
GEARBOX UNIT					
Gear stop cam	Screw M6x30 TSPCE	10.9	1	Medium resistant thread stoppers	11
Gearbox control lever	Bolt 6x25	8.8	1	Medium resistant thread stoppers	10
CLUTCH UNIT					
Clutch-nut	Special Nut M14x1,25x6 ch10	0,4	1	Medium resistant thread stoppers	70
Clutch cap	Bolt M6x16 ch10	8.8	6		10

* For a 125 cc engine



TABLE OF TIGHTENING TORQUES OF THE ENGINE-FRAME

Fastening	Component	Cl.R.	Pcs.	Thread stoppers	Torque [Nm]
ENGINE TO FRAME ANCHOR					
Front fitting	Bolt M10x1.5x127	5.8	1		25
Rear fitting	Bolt M10x1.25x100	5.8	1		30
Engine head fitting	Bolt M8x1.25x55	8.8	1		30
Engine bracket fitting	Bolt M6x1x50	8.8	2		10
Engine/Swing arm/Frame	Bolt M16x1.25x255	5.8	1		50
Engine arms/Frame	Screw M8x1.25x16	8.8	4		25
ENGINE PROTECTION PLATE UNIT					
Engine protection plate (front)	Screw M8x1.25x16	8.8	2		20
Engine protection plate (rear)	Screw M8x1.25x20	8.8	2		30

ENGINE SPECIFICATIONS

Type	BETA6605 ZD39T A		BETA6605 ZD3B9T		BETA6605 ZD3B9T F		BETA6605 ZD3B9T I	
no. of cylinders	1		1		1		1	
Bore	54,0 mm		64,0 mm		72,5 mm		78,0 mm	
Stroke	54,0 mm		60,5 mm		60,5 mm		60,5 mm	
Total Cubic Capacity	125 cm ³		194,6 cm ³		249,7 cm ³		289,1 cm ³	
Compression ratio	MY10: 14,01	Factory MY10 125 MY11 16,1:1	11,8:1		8,9:1		9,5:1	
Ignition	Electronic AET 12V - 85W		Electronic AET 12V - 85W		Electronic AET 12V - 85W		Electronic AET 12V - 85W	
Spark plug	NGK BR7ES		NGK BR7ES		NGK BR7ES		NGK BR7ES	
Primary drive ratio	3,55							
Transmission ratio in	I	II	III	IV	V	VI		
	10,058	8,114	6,863	5,325	3,254	2,282		
Supply								
Carburettor	Keihin PWK F28 mm		Mikuni VM F26 mm	Keihin PWK F28 mm	Keihin PWK F28 mm		Keihin PWK F28 mm	
Jets MY10	Min:55 Max:130 Factory Min:52 Max:130		Min:30 Max:150		Min:48 Max:125		Min:48 Max:125	
Jets MY11	Min:55 Max:130		Min:30 Max:150	Min:48 Max:125	Min:48 Max:125		Min:48 Max:125	
Needle	JJH		JJH		JJH		JJH	
Clip	IV		IV		IV		IV	
Mixture	1.5% synthetic oil; 4% mineral oil		1.5% synthetic oil; 4% mineral oil		1.5% synthetic oil; 4% mineral oil		1.5% synthetic oil; 4% mineral oil	

RECOMMENDED LUBRICANTS AND LIQUIDS

APPLICATION	PRODUCT	QUANTITY
Gearbox and clutch box	BARDAHL GEAR BOX 20W40	550 ml
Supply	BARDAHL KXT	1,5% (percentage of oil with respect to fuel)
Cooling system	BARDAHL PERMANENT FLUID ANTIFREEZE	500 ml





Beta
the play bike

BETAMOTOR S.P.A.
PIAN DELL'ISOLA, 72
50067 RIGNANO SULL'ARNO (FIRENZE) ITALIA
INFO@BETAMOTOR.COM WWW.BETAMOTOR.COM