

RR 4T 125cc LC ENDURO 2019

CATALOG OF SPARE PARTS

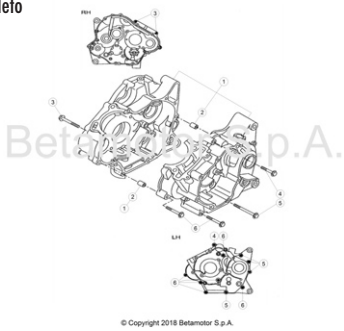

The images and content herein are the exclusive property of Betamotor SpA, which reserves all rights thereto. Any reproduction, modification, editing, dissemination, communication, exploitation in any form and way, original or derived, is strictly forbidden if not expressly approved in writing by Betamotor SpA. Any violation will be actively pursued in all relevant civil and criminal forums by Betamotor SpA.

TAV.01 Carter completo - Crankcase, assy - Carter complet - Kurbelwellengehäuse, KPL. - Carter completo



Pag. 6

TAV.01A Coperchio frizione - Clutch cover - Couvercle d'embrague - Kupplungsdeckel - Tapa embrague

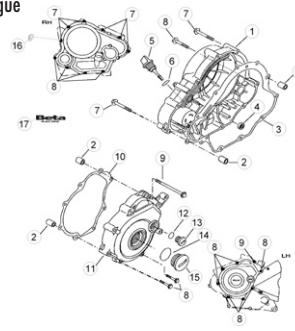

Pag. 7

TAV.02 Albero motore - Crankshaft - Vilebrequin - Kurbelwelle - Cigüeñal

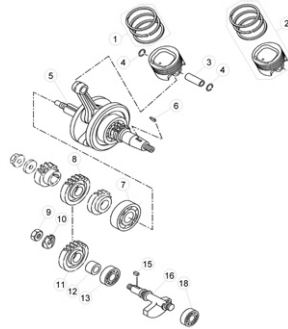

Pag. 8

TAV.03 Frizione - Clutch - Embrayage - Kupplung - Embrague

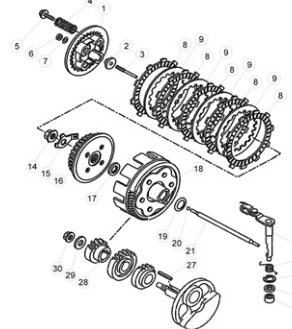

Pag. 10

TAV.04 Ingranaggi cambio - Gear group - Engrenages changement de vitesses - Schaltgetriebe - Engranaje del cambio

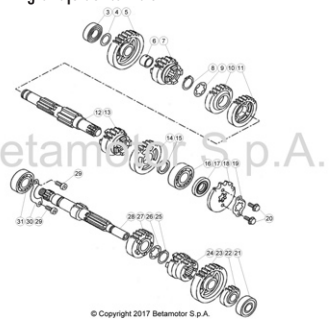

Pag. 12

TAV.05 Comando cambio - Gear shift control - Commande changement de vitesse - Chaltung - Mando cambio

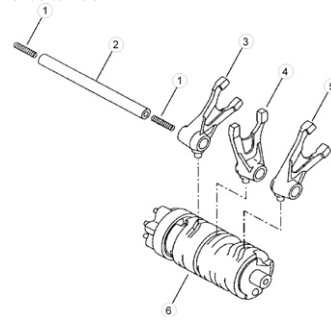

Pag. 13

TAV.05A Avviamento a pedale - Kickstarter - Démarrage à pedal - Pedalstart - Arranque a pedal

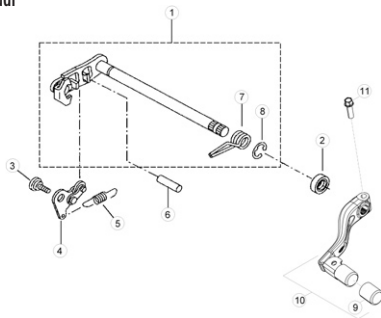

Pag. 14

TAV.07 Avviamento elettrico - Electric starter - Démarrage électrique - Elektrischer start - Arranque eléctrico

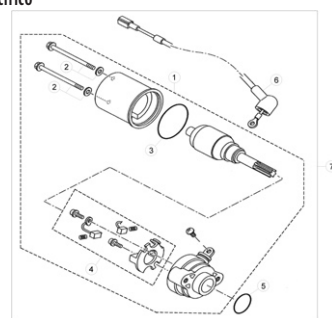

Pag. 15

TAV.07A Ruota libera - Free wheel - Roue libre - Freilauf - Rueda libre

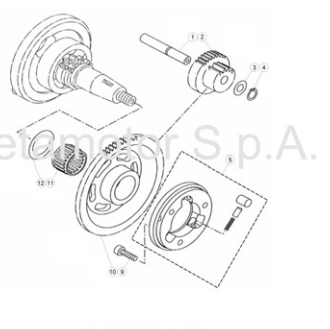

Pag. 16

TAV.08 Impianto di lubrificazione - Lubrication system - Système de lubrification - Schmieranlage - Sistema de lubricación

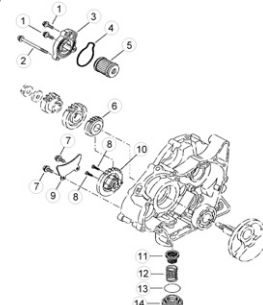

Pag. 17



Beta
motorcycles

TAV.09 Pompa acqua - Water pump - Pompe a eau - Wasserpumpe - Bomba agua

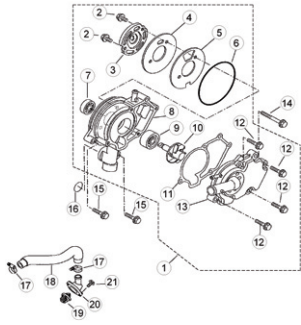

Pag. 18

TAV.10 Gruppo accensione elettronica - Electronic ignition assy. - Groupe allumage électronique - Elektronischezündung gruppe - Grupo encendido electrónico

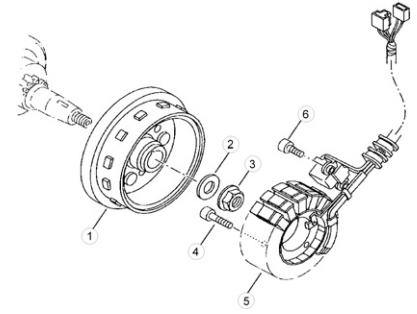

Pag. 19

TAV.11 Cilindro completo - Cylinder, assy - Cylindre complet - Zylinder, KPL. - Cilindro completo

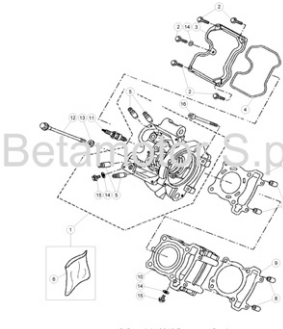

Pag. 20

TAV.11A Valvole - Valves - Soupapes - Ventil - Válvulas

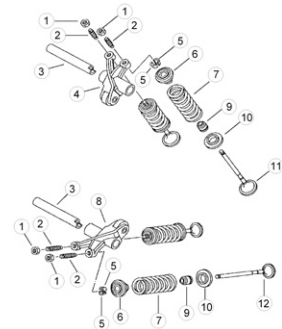

Pag. 21

TAV.11B Catena distribuzione - Timing chain - Chaîne de distribution - Steuerkette - Cadena de distribución

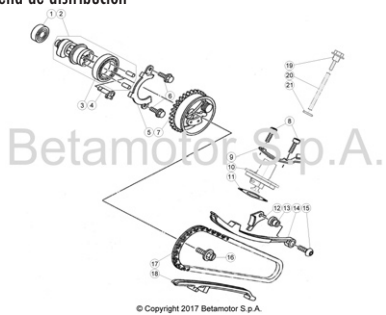

Pag. 22

TAV.12 Carburatore - Carburettor - Carburateur - Vergaser - Carburador

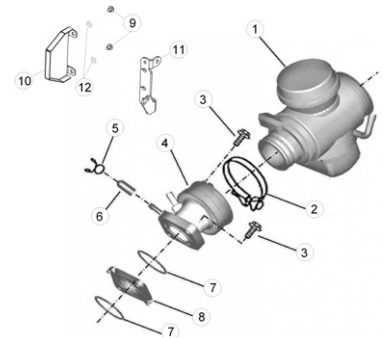

Pag. 23

TAV.12A Carburatore - Carburettor - Carburateur - Vergaser - Carburador

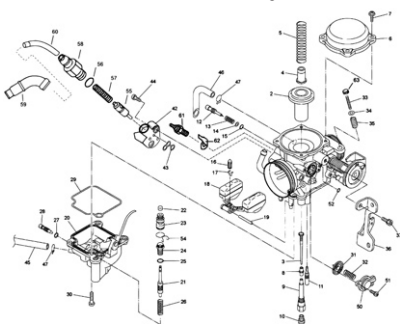

Pag. 24

TAV.31 Telaio - Frame - Chassis - Rahmen - Chasis

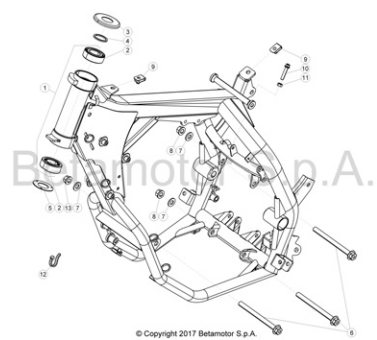

Pag. 26

TAV.32 Accessori telaio - Frame accessories - Accessoires chassis - Rahmenzubehören - Accesorios Chasis

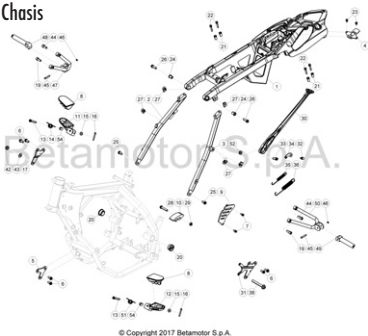

Pag. 28

TAV.33 Forcellone posteriore - Rear fork - Fouche arriere - Hinterradschwinge - Horquilla posterior

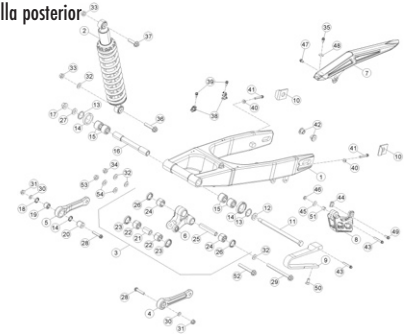

Pag. 30

TAV.34 Forcella anteriore - Front fork - Fourche AV. - Vorderradgabel - Horquilla delantera



Pag. 32

TAV.35 Comandi-Manubrio - Controls-Handlebars - Commandes-Guidon - Bedienungselemente-Lenker - Mandos-Manillar

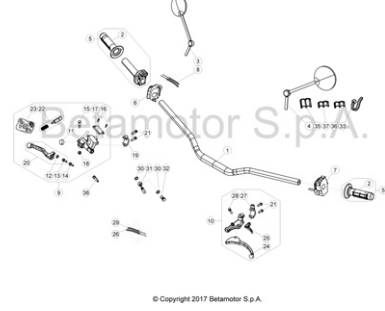

Pag. 34

TAV.36 Impianto freni idraulici - Hydraulic brakes system - Installation des freins hydrauliques - Hidraulischebremse anlage - Instalación freno hidráulico

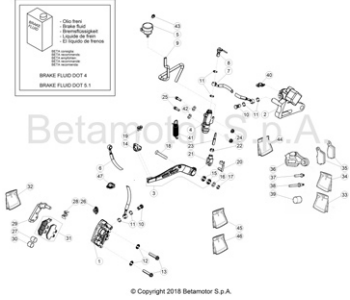

Pag. 36

TAV.37 Gruppo scarico - Exhaust system - Echappement - Auspuffanlage - Grupo escape

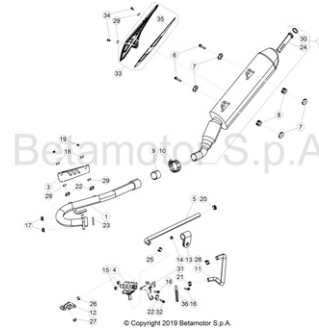

Pag. 38

TAV.38 Scatola filtro - Filter box - Boîtier du filtre - Sicherungskasten - Caja del filtro

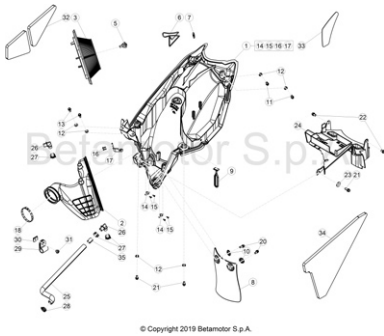

Pag. 40

TAV.39 Impianto di raffreddamento - Installation de refroidissement - Installation de refroidissement - Kühlsystem - Instalación de enfriamiento

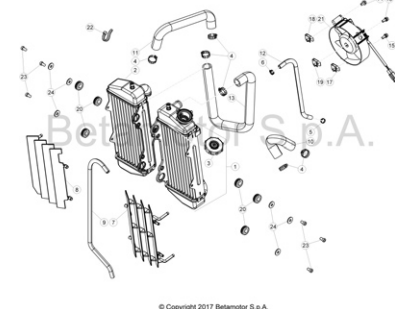

Pag. 42

TAV.40 Impianto elettrico - Electrical equipment - Installation électrique - Elektrische anlage - Instalación eléctrica



Pag. 44

TAV.41 Ruota anteriore ENDURO - Front wheel ENDURO - Roue AV. ENDURO - Vorderrad ENDURO - Rueda delantera ENDURO

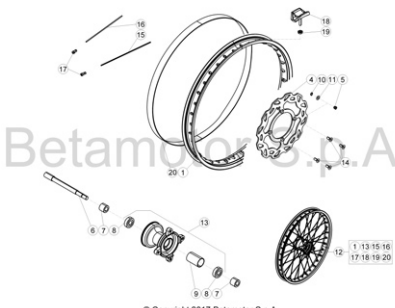

Pag. 46

TAV.41A Ruota anteriore MOTARD - Front wheel MOTARD - Roue AV. MOTARD - Vorderrad MOTARD - Rueda delantera MOTARD

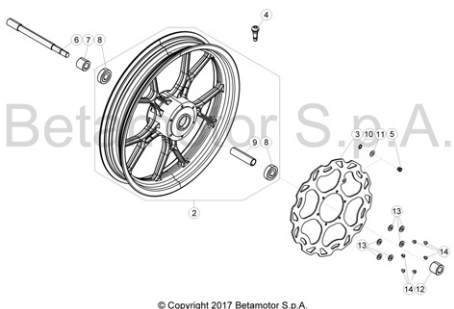

Pag. 47

TAV.42 Ruota posteriore ENDURO - Rear wheel ENDURO - Roue AR. ENDURO - Hinterrad ENDURO - Rueda trasera ENDURO



Pag. 48



TAV.42A Ruota posteriore MOTARD - Rear wheel MOTARD - Roue AR. MOTARD - Hinterrad MOTARD - Rueda trasera MOTARD

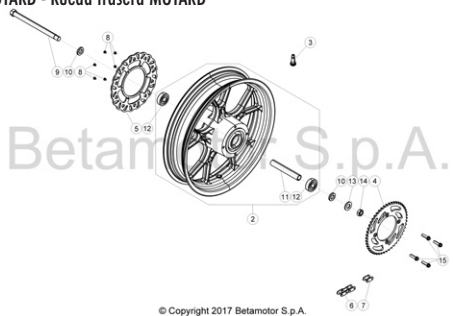

© Copyright 2017 Betamotor S.p.A.

Pag. 49

TAV 43 Carenature-Serbatoio-Sella - Fairings-Tank-Saddle - Carenages-Reservoir-Selle - Verkleidungen-Tank-Sattel - Carenados-Deposito-Sillin **ENDURO**



© Copyright 2019 Betamotor S.p.A.

Pag. 50

TAV 43 Carenature-Serbatoio-Sella - Fairings-Tank-Saddle - Carenages-Reservoir-Selle - Verkleidungen-Tank-Sattel - Carenados-Deposito-Sillin **MOTARD**

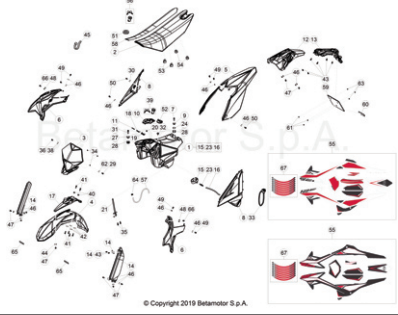

© Copyright 2019 Betamotor S.p.A.

Pag. 54

TAV.44 Attrezzatura specifica - Special tools - Outillage spéciale - Spezialwerkzeug - Utillaje específico

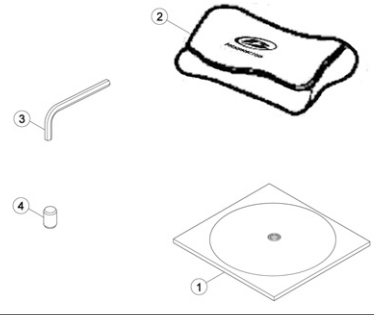

Pag. 58

Tav.01

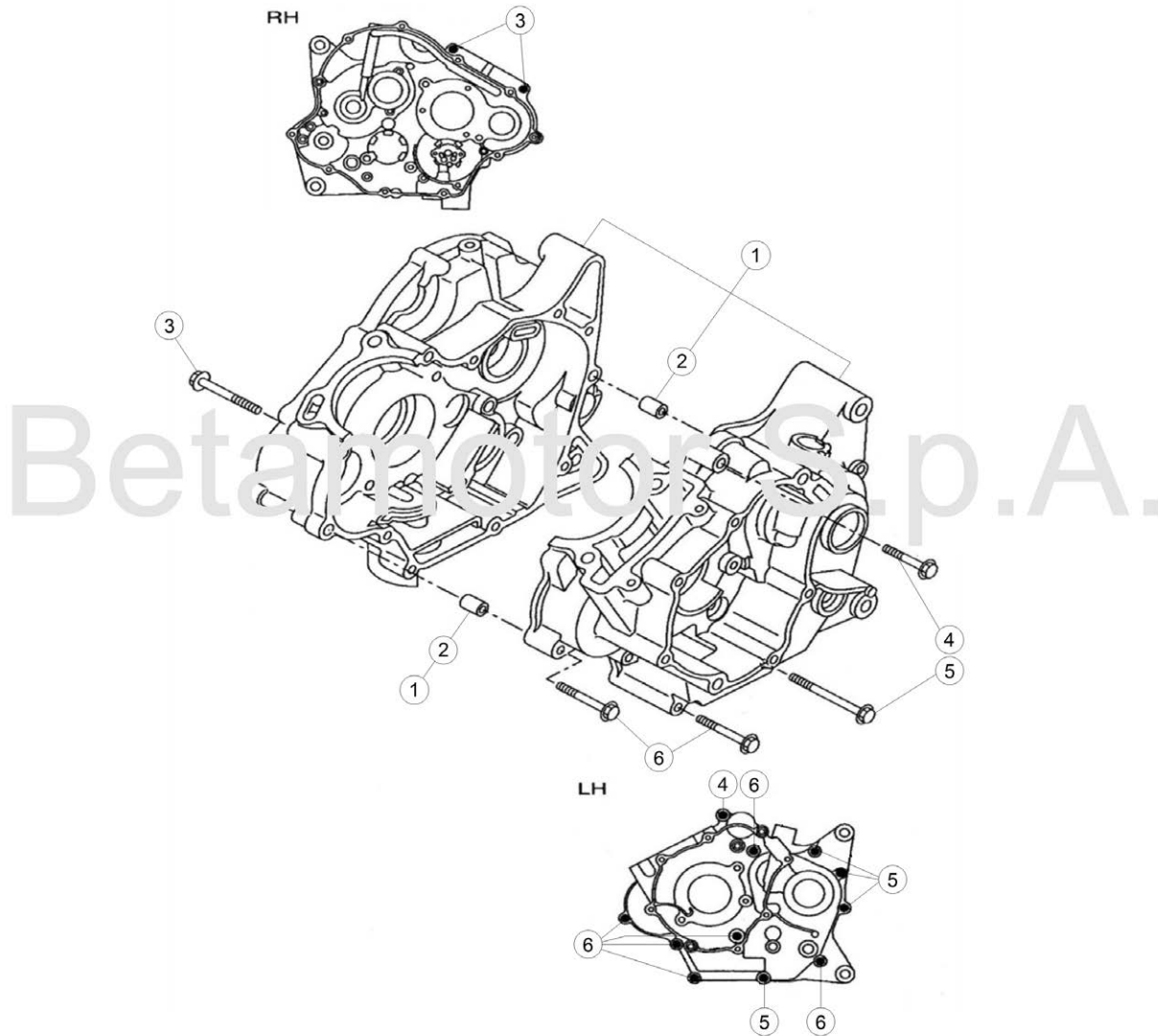

© Copyright 2018 Betamotor S.p.A.

Pos Loc Pos Ps Pos	Numero Number Numéro Número Nummer	Q.tà Q.ty Q.té M.ge C.ad	Nota Note Note Nota Anm.	Descrizione	Description	Désignation	Beschreibung	Descripció
1	021.01.000.80.00	1		Coppia carter	Crankcase pair	Paire carter	Gehäusepaar	Par cárter
2	021.01.001.00.00	2		Grano di riferimento D.10x14-INT.D.8,5	Dowel D.10x14-INT.D.8,5	Repère D.10x14-INT.D.8,5	Passstift D.10x14-INT.D.8,5	Centraje D.10x14-INT.D.8,5
3	021.01.002.00.00	2		Vite TE M6x55	Screw TE M6x55	Vis TE M6x55	Schraube TE M6x55	Tornillo TE M6x55
4	021.01.003.00.00	1		Vite TE M6x40	Screw TE M6x40	Vis TE M6x40	Schraube TE M6x40	Tornillo TE M6x40
5	021.01.004.00.00	4		Vite TE M6x70	Screw TE M6x70	Vis TE M6x70	Schraube TE M6x70	Tornillo TE M6x70
6	021.01.005.00.00	6		Vite TE M6x45	Screw TE M6x45	Vis TE M6x45	Schraube TE M6x45	Tornillo TE M6x45

Tav.01A

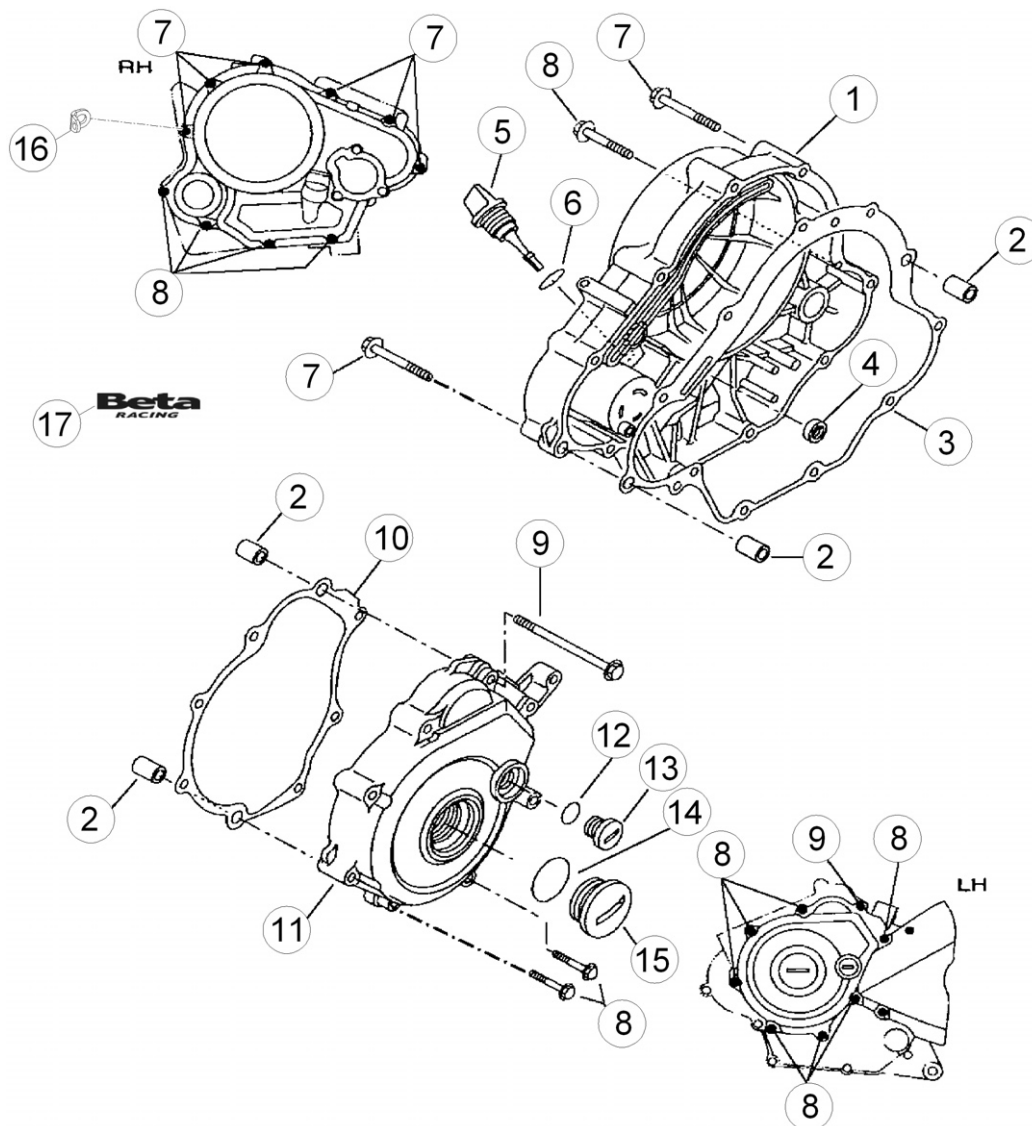

Pos Loc Pos Ps Pos	Numero Number Numéro Número Nummer	Q.tà Q.ty Q.té M.ge C.ad	Nota Note Note Nota Anm.	Descrizione	Description	Désignation	Beschreibung	Descripción
1	021.01.019.00.00	1		Coperchio frizione	Clutch cover	Couvercle d'embrayage	Kupplungsdeckel	Tapa embrague
2	021.01.001.00.00	4		Grano di riferimento D.10x14-INT.D.8,5	Dowel D.10x14-INT.D.8,5	Repère D.10x14-INT.D.8,5	Passstift D.10x14-INT.D.8,5	Centraje D.10x14-INT.D.8,5
3	021.01.007.00.00	1		Guarnizione coperchio frizione	Clutch cover gasket	Joint couvercle embrayage	Dichtung Kupplungsabdeckung	Junta tapa embrague
4	021.01.008.00.00	1		Paraolio D.18X10X6	Oil seal D.18X10X6	Pare-huile D.18X10X6	Dichtring D.18X10X6	Sello de lub. D.18X10X6
5	021.01.009.00.00	1		Tappo con asta livello olio	Plug w/Oil Dipstick	Bouchon Avec Jauge Niveau Huile	Ölmesstabschraube	Tapón con Varilla Nivel Aceite
6	021.09.014.00.00	1		Anello di tenuta D.19X2,4	Oil seal D.19X2,4	Joint spie D.19X2,4	Dichtring D.19X2,4	Retén de aceite D.19X2,4
7	021.01.010.00.00	6		Vite TE M6x50	Screw TE M6x50	Vis TE M6x50	Schraube TE M6x50	Tornillo TE M6x50
8	021.01.003.00.00	11		Vite TE M6x40	Screw TE M6x40	Vis TE M6x40	Schraube TE M6x40	Tornillo TE M6x40
9	021.01.011.00.00	1		Vite TE M6x90	Screw TE M6x90	Vis TE M6x90	Schraube TE M6x90	Tornillo TE M6x90
10	021.01.012.00.00	1		Guarnizione coperchio volano	Alternator cover gasket	Garniture couvercle alternateur	Alternatordeckeldichtung	Junta tapa alternador
11	021.01.020.00.00	1		Coperchio volano	Flywheel cover	Carter volant	Schwungraddeckel	Tapa volante
12	021.01.014.00.00	1		Anello OR D.13,5x2,2	O-Ring D.13,5x2,2	Bague d'étanchéité D.13,5x2,2	O-Ring D.13,5x2,2	Anillo OR D.13,5x2,2
13	021.01.021.00.00	1		Tappo	Plug	Bouchon	Verschluß	Tapón
14	021.01.016.00.00	1		Anello tenuta D.31,5x2,4	Oil seal D.31,5x2,4	Bague d'étanchéité D.31,5x2,4	Dichtring D.31,5x2,4	Reten de ac. D.31,5x2,4
15	021.01.022.00.00	1		Tappo	Plug	Bouchon	Verschluß	Tapón
16	25.57912.000	1		Fissaggio molla collettore	Retaining plate, manifold spring	Plaque de fixation ressort de coll.	Befestigungsplatte krümmfeder	Pastilla de fijación del muelle colector
17	014.43.010.00.00	1		Decalco BETA	BETA decalcomania	Décalcomanie BETA	Abziehbild BETA	Calcomanía BETA

Tav.02

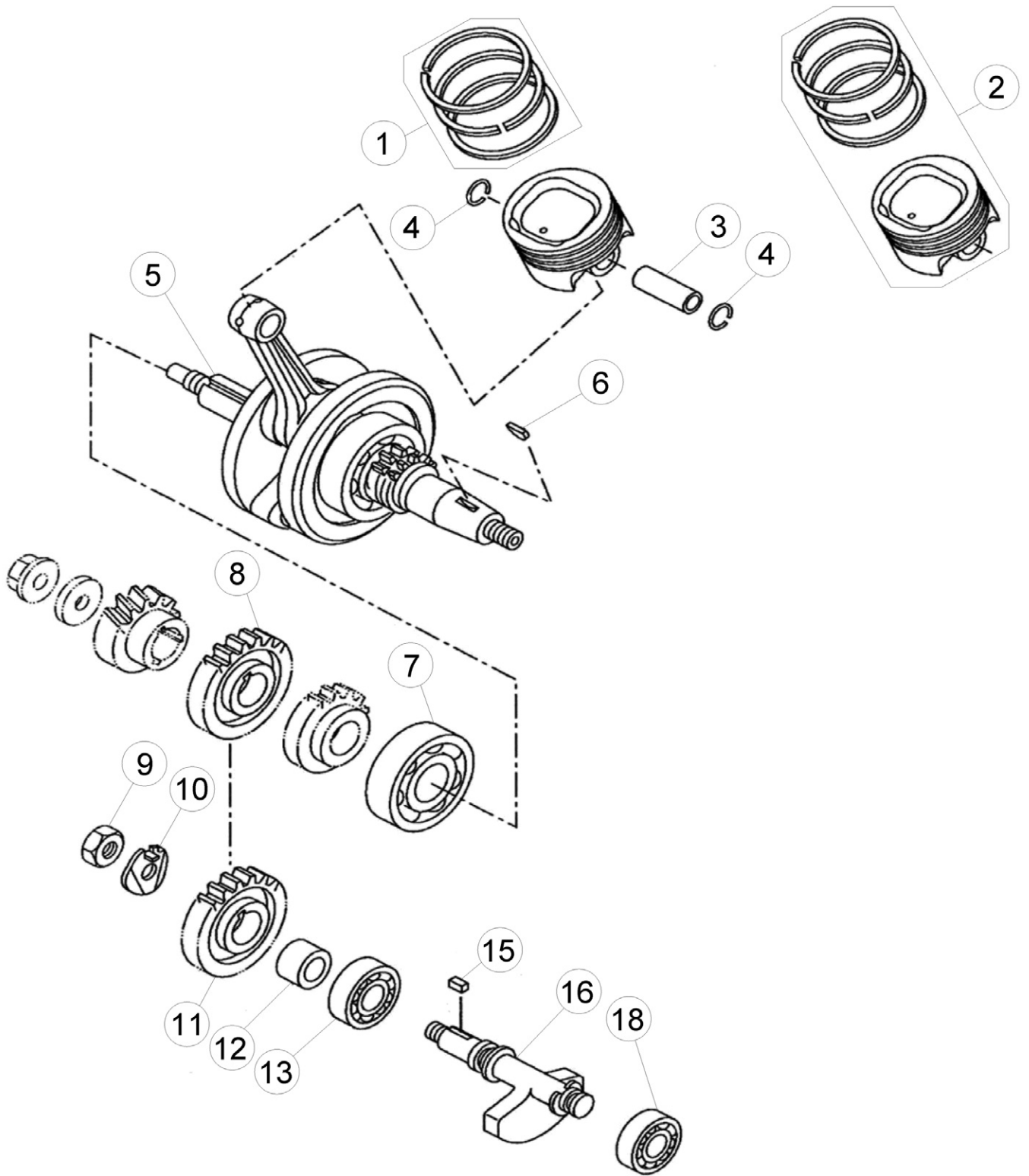

Tav.02

Pos Loc Pos Ps Pos	Numero Number Numéro Número Nummer	Q.tà Q.ty Q.té M.ge C.ad	Nota Note Note Nota Anm.	Descrizione	Description	Désignation	Beschreibung	Descripcìon
1	021.02.018.82.00	1		Serie segmenti	Ring set	Serie segments	Set Kolberringe	Serie segmentos
2	021.02.023.80.00	1		Pistone	Piston	Piston	Kolben	Pistón
3	021.02.002.00.00	1		Spinotto D.14x37	Pin D.14x37	Axe D.14x37	Zapfen D.14x37	Eje D.14x37
4	021.02.003.00.00	2		Anello elastico ferma-spinotto D.14	Piston pin circlip D.14	Bague élastique bloque-axe D.14	Sprengring zur Bolzenfeststellung D.14	Anillo elástico bloquea-clavija D.14
5	021.02.004.00.00	1		Imbiellaggio completo	Crankshaft assembly	Vilebrequin complet	Kurbelwelle Kpl.	Gr. bielas completo
6	021.02.005.00.00	1		Chiavetta lato volano D.13x3x5	Flywheel Key D.13x3x5	Clavette D.13x3x5	Keil D.13x3x5	Chaveta D.13x3x5
7	021.02.006.00.00	1		Cuscinetto D.25x62x17	Bearing D.25x62x17	Roulement D.25x62x17	Lager D.25x62x17	Cojinete D.25x62x17
8	021.02.007.00.00	1		Ingranaggio conduttore contralbero	Countershaft driving gear	Engrenage conducteur du contre-arbre	Vorgelegewelle Antriebszahnrad	Engr. accionador del contraeje
9	021.02.008.00.00	1		Dado M10X1 H=8	Nut M10X1 H=8	Ecrou M10X1 H=8	Mutter M10X1 H=8	Tuerca M10X1 H=8
10	021.02.009.00.00	1		Rondella 10,2x28x0,8	Washer 10,2x28x0,8	Rondelle 10,2x28x0,8	U.Scheibe 10,2x28x0,8	Arandela 10,2x28x0,8
11	021.02.010.00.00	1		Ingranaggio condotto contralbero	Countershaft driven gear	Engrenage entraîné du contre-arbre	Vorgelegewelle Angetriebenes Zahnrad	Engr. conducido del contraeje
12	021.02.011.00.00	1		Distanziale	Spacer	Entretoise	Distanzstück	Distanciadador
13	021.02.012.00.00	1		Cuscinetto a sfere D.35x15x11	Ball bearing D.35x15x11	Roulement à billes D.35x15x11	Kugellager D.35x15x11	Cojinete de bolas D.35x15x11
15	021.02.014.00.00	1		Chiavetta 5x5x6	Key 5x5x6	Clavette 5x5x6	Keil 5x5x6	Chaveta 5x5x6
16	021.02.015.00.00	1		Contralbero	Countershaft	Contre-arbre	Vorgelegewelle	Contraeje
18	021.02.017.00.00	1		Cuscinetto a sfere D.40x17x12	Ball bearing D.40x17x12	Roulement à billes D.40x17x12	Kugellager D.40x17x12	Cojinete de bolas D.40x17x12

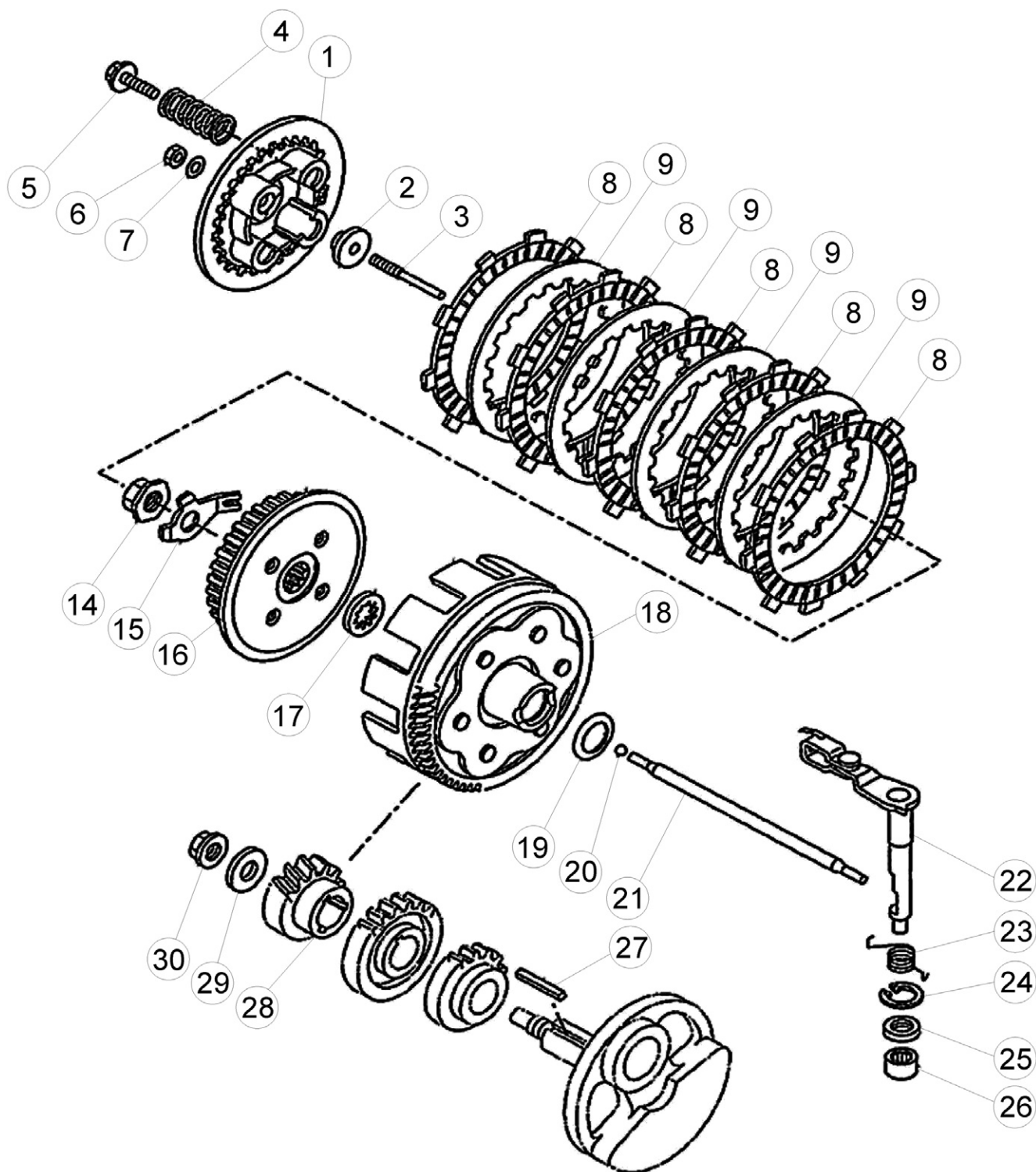

Tav.03

Pos Loc Ps Pos	Numero Number Numéro Número Nummer	Q.tà Q.ty Q.té M.ge C.ad	Nota Note Note Nota Anm.	Descrizione	Description	Désignation	Beschreibung	Descripción
1	021.03.032.00.00	1		Spingidisco frizione	Clutch pressure plate	Plateau de pression	Kupplungsdruckplatte	Placa de presión de embrague
2	021.03.031.00.00	1		Piattello	Plate	Disque	Platte	Platillo
3	021.03.039.00.00	1		Perno guida frizione	Clutch Guide Pin	Axe de Guidage Embrayage	Kupplungsführungsstift	Perno Guía Embrague
4	021.03.037.00.00	4		Molla frizione	Clutch spring	Ressort embr.	Kupplg.feder	Muelle embr.
5	021.03.004.00.00	4		Vite	Screw	Vis	Schraube	Tornillo
6	021.03.005.00.00	1		Dado	Nut	Ecrou	Mutter	Tuerca
7	021.03.006.00.00	1		Rondella	Washer	Rondelle	U.Scheibe	Arandela
8	021.03.034.00.00	5		Disco conduttore	Driving plate	Disque menant	Kup.-streibscheibe	Disco conductor
9	021.03.033.00.00	4		Disco condotto	Driven plate	Disque entrainé	Scheibe, getrieben	Disco conducido
14	021.03.013.00.00	1		Dado M14x1 H=8	Nut M14x1 H=8	Ecrou M14x1 H=8	Mutter M14x1 H=8	Tuerca M14x1 H=8
15	021.03.014.00.00	1		Rondella	Washer	Rondelle	U.Scheibe	Arandela
16	021.03.036.00.00	1		Tamburo frizione	Clutch drum	Tambour d'embr.	Kupplungstrommel	Tambor de embr.
17	021.03.041.00.00	1		Rondella	Washer	Rondelle	U.Scheibe	Arandela
18	021.03.042.00.00	1		Campana frizione	Clutch housing	Cage embrayage	Kupplungskorb	Campana embrague
19	021.03.018.00.00	1		Rondella conica D.20x28,5x0,3	Conical Washer D.20x28,5x0,3	Rondelle conique D.20x28,5x0,3	Kegelscheibe D.20x28,5x0,3	Arandela cónica D.20x28,5x0,3
20	021.03.038.00.00	1		Sfera D.7,93	Ball D.7,93	Bille D.7,93	Kugel D.7,93	Bola D.7,93
21	021.03.040.00.00	1		Asta spingidisco frizione	Clutch Pushrod	Tige Presse-disque Embrayage	Kupplungsscheibendruckstab	Varilla Empuja-disco Embrague
22	021.03.030.00.00	1		Leva	Lever	Levier	Hebel	Palanca
23	021.03.022.00.00	1		Molla ritorno asta frizione	Return spring clutch fl. dipstick	Ressort de retour axe embrayage	Rückschlagfeder Kupplungsstange	Muelle de retorno varilla embrague
24	021.03.023.00.00	1		Anello seeger D.20	Snap ring D.20	Circlips D.20	Seegerring D.20	Anillo seeger D.20
25	021.03.024.00.00	1		Paraolio D.18x12x5	Oil seal D.18x12x5	Pare-huile D.18x12x5	Dichtring D.18x12x5	Sello de lub. D.18x12x5
26	021.03.025.00.00	1		Gabbia a rulli D.12x16x10	Roller cage D.12x16x10	Cage a roul. D.12x16x10	Rollenkäfig D.12x16x10	Jaula de rod. D.12x16x10
27	021.03.026.00.00	1		Chiavetta 5x5x33	Key 5x5x33	Clavette 5x5x33	Keil 5x5x33	Chaveta 5x5x33
28	021.03.027.00.00	1		Pignone motore Z=24	Engine sprocket Z=24	Pignon moteur Z=24	Motorritzel Z=24	Piñón motor Z=24
29	021.03.028.00.00	1		Rondella piana D.12,2x30x3	Plain washer D.12,2x30x3	Rondelle plate D.12,2x30x3	U.Scheibe D.12,2x30x3	Arandela plana D.12,2x30x3
30	021.03.029.00.00	1		Dado M12X1 H=8	Nut M12X1 H=8	Ecrou M12X1 H=8	Mutter M12X1 H=8	Tuerca M12X1 H=8

Tav.04

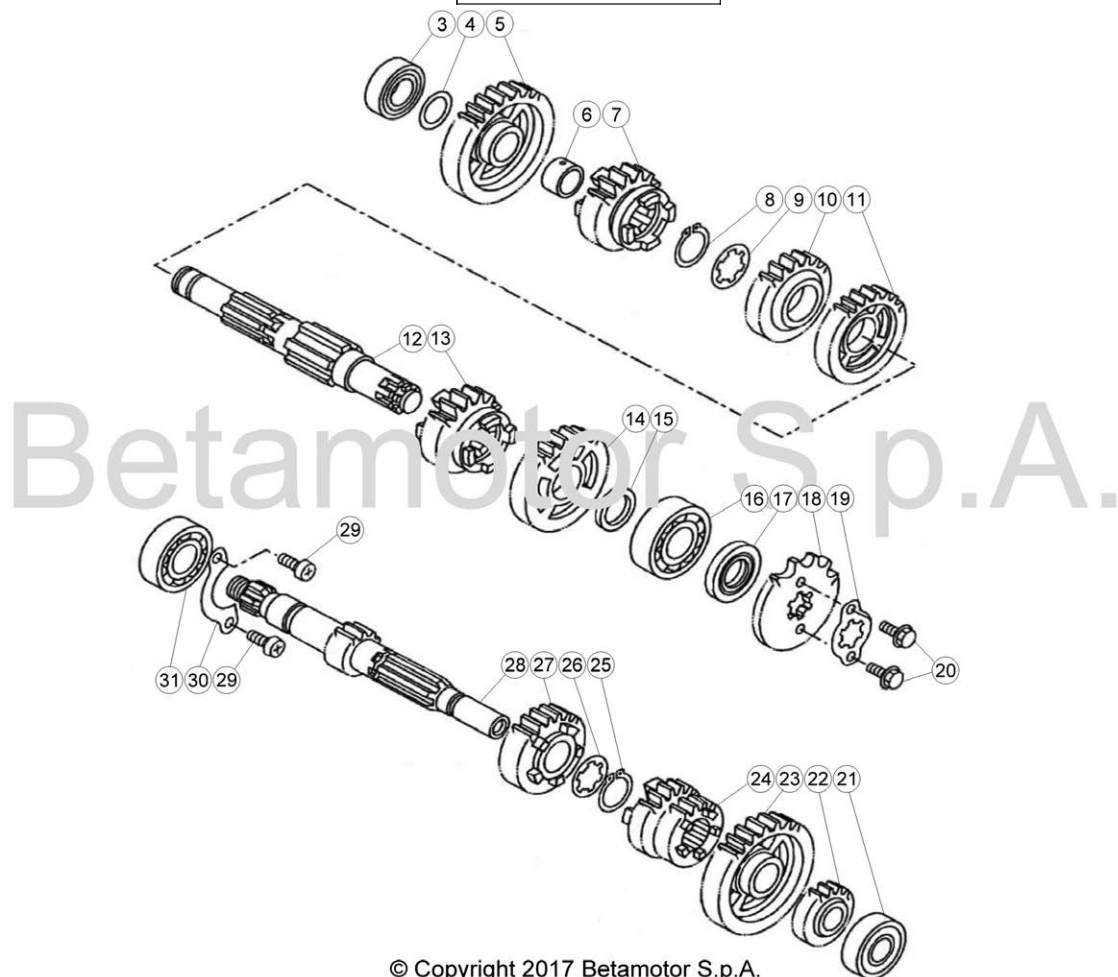

© Copyright 2017 Betamotor S.p.A.

Pos Loc Pos Ps Pos	Numero Number Numéro Número Nummer	Q.tà Q.ty Q.té M.ge C.ad	Nota Note Note Nota Anm.	Descrizione	Description	Désignation	Beschreibung	Descripción
3	021.04.002.00.00	1		Cuscinetto a sfere D.35x17x10	Ball bearing D.35x17x10	Roulement à billes D.35x17x10	Kugellager D.35x17x10	Cojinete de bolas D.35x17x10
4	021.04.003.00.00	1		Rondella	Washer	Rondelle	U.Scheibe	Arandela
5	021.04.004.00.00	1		Ingranaggio 1° Albero Secondario	1st Gear, Lay Shaft	Pignon 1er Arbre Secondaire	1. Zahnrad Sekundärwelle	Engranaje 1° Árbol Secundario
6	021.04.005.00.00	1		Boccola	Bush	Moyeu	Büchse	Buje
7	021.04.031.00.00	1		Ingranaggio 5° Albero Secondario	5th Gear, Lay Shaft	Pignon 5ème Arbre Secondaire	5. Zahnrad Sekundärwelle	Engranaje 5° Árbol Secundario
8	021.04.007.00.00	1		Anello seeger	Snap ring	Circlips	Seegerring	Anillo seeger
9	021.04.008.00.00	1		Rondella	Washer	Rondelle	U.Scheibe	Arandela
10	021.04.032.00.00	1		Ingranaggio 4° Albero Secondario	4th Gear, Lay Shaft	Pignon 4ème Arbre Secondaire	4. Zahnrad Sekundärwelle	Engranaje 4° Árbol Secundario
11	021.04.033.00.00	1		Ingranaggio 3° Albero Secondario	3rd Gear, Lay Shaft	Pignon 3ème Arbre Secondaire	3. Zahnrad Sekundärwelle	Engranaje 3° Árbol Secundario
12	021.04.011.00.00	1		Albero secondario completo	Complete lay shaft	Arbre secondaire complet	Komplette Vorgelegewelle	Arbol primario completo
13	021.04.012.00.00	1		Ingranaggio 6° Albero Secondario	6th Gear, Lay Shaft	Pignon 6ème Arbre Secondaire	6. Zahnrad Sekundärwelle	Engranaje 6° Árbol Secundario
14	021.04.034.00.00	1		Ingranaggio 2° Albero Secondario	2nd Gear, Lay Shaft	Pignon 2ème Arbre Secondaire	2. Zahnrad Sekundärwelle	Engranaje 2° Árbol Secundario
15	021.04.014.00.00	1		Rondella	Washer	Rondelle	U.Scheibe	Arandela
16	021.04.015.00.00	1		Cuscinetto a sfere D.47x20x14	Ball bearing D.47x20x14	Roulement à billes D.47x20x14	Kugellager D.47x20x14	Cojinete de bolas D.47x20x14
17	021.04.016.00.00	1		Paraolio D.20x35x5	Oil seal D.20x35x5	Pare-huile D.20x35x5	Dichtring D.20x35x5	Sello de lub. D.20x35x5
18	021.04.017.00.00	1		Ingranaggio rinvio Z=14	Intermediate gear Z=14	Engrenage de renvoi Z=14	Vorgelegerad Z=14	Engranaje intermedio Z=14
19	021.04.018.00.00	1		Piastrina ferma-pignone	Sprocket keep plate	Plaque fixe pignon	Ritzfeststellplättchen	Placa sujeta-piñón
20	021.04.019.00.00	2		Vite TE M6x10	Screw TE M6x10	Vis TE M6x10	Schraube TE M6x10	Tornillo TE M6x10
21	021.04.020.00.00	1		Cuscinetto a sfere D.35x15x11	Ball bearing D.35x15x11	Roulement à billes D.35x15x11	Kugellager D.35x15x11	Cojinete de bolas D.35x15x11
22	021.04.021.00.00	1		Ingranaggio 2° Albero Primario	2nd Gear, Main Shaft	Pignon 2ème Arbre Primaire	2. Zahnrad Primärwelle	Engranaje 2° Árbol Primario
23	021.04.035.00.00	1		Ingranaggio 6° Albero Primario	6th Gear, Main Shaft	Pignon 6ème Arbre Primaire	6. Zahnrad Primärwelle	Engranaje 6° Árbol Primario
24	021.04.023.00.00	1		Ingranaggio 3° Albero Primario	3rd Gear, Main Shaft	Pignon 3ème Arbre Primaire	3. Zahnrad Primärwelle	Engranaje 3° Árbol Primario
25	021.04.024.00.00	1		Anello seeger	Snap ring	Circlips	Seegerring	Anillo seeger
26	021.04.025.00.00	1		Rondella	Washer	Rondelle	U.Scheibe	Arandela
27	021.04.036.00.00	1		Ingranaggio 5° Albero Primario	5th Gear, Main Shaft	Pignon 5ème Arbre Primaire	5. Zahnrad Primärwelle	Engranaje 5° Árbol Primario
28	021.04.027.00.00	1		Albero primario	Mainshaft	Arbre primaire	Hauptwelle	Arbol primario
29	021.04.028.00.00	2		Vite t.c.c.e. M6X12	Screw t.c.c.e. M6X12	Vis t.c.c.e. M6X12	Schraube t.c.c.e. M6X12	Tornillo t.c.c.e. M6X12
30	021.04.029.00.00	1		Piastrina cuscinetto albero primario	Plate position ball bearings	Butée de roulement	Kugellagerprimdrachse	Precinto cojinete eje primario
31	021.04.030.00.00	1		Cuscinetto a sfere D.42x20x12	Ball bearing D.42x20x12	Roulement à billes D.42x20x12	Kugellager D.42x20x12	Cojinete de bolas D.42x20x12

Tav.05

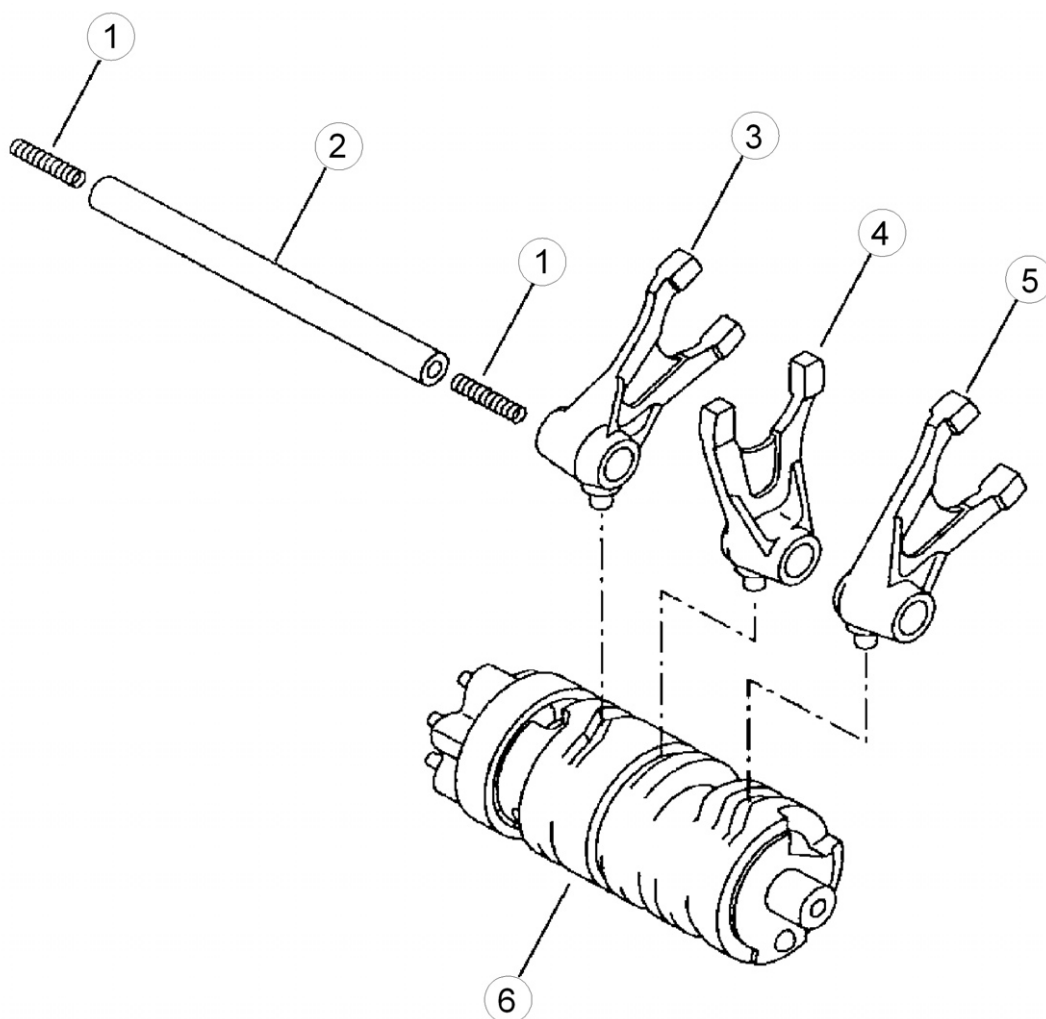

Pos Loc Pos Ps Pos	Numero Number Numéro Número Nummer	Q.tà Q.ty Q.té M.ge C.ad	Nota Note Note Nota Anm.	Descrizione	Description	Désignation	Beschreibung	Descripción
1	021.05.001.00.00	2		Molla	Spring	Ressort	Feder	Muelle
2	021.05.002.00.00	1		Perno guida forchetta	Selector pin	Pivot guide fourche	Schaltgabel Pin	Eje horquilla
3	021.05.003.00.00	1		Forchetta	Fork	Fourchette	Schaltgabel	Horquilla
4	021.05.004.00.00	1		Forchetta	Fork	Fourchette	Schaltgabel	Horquilla
5	021.05.005.00.00	1		Forchetta	Fork	Fourchette	Schaltgabel	Horquilla
6	021.05.006.00.00	1		Desmodromico	Desmodromic	Desmodromique	Zwangsläufig	Desmodrómico

Tav.05A

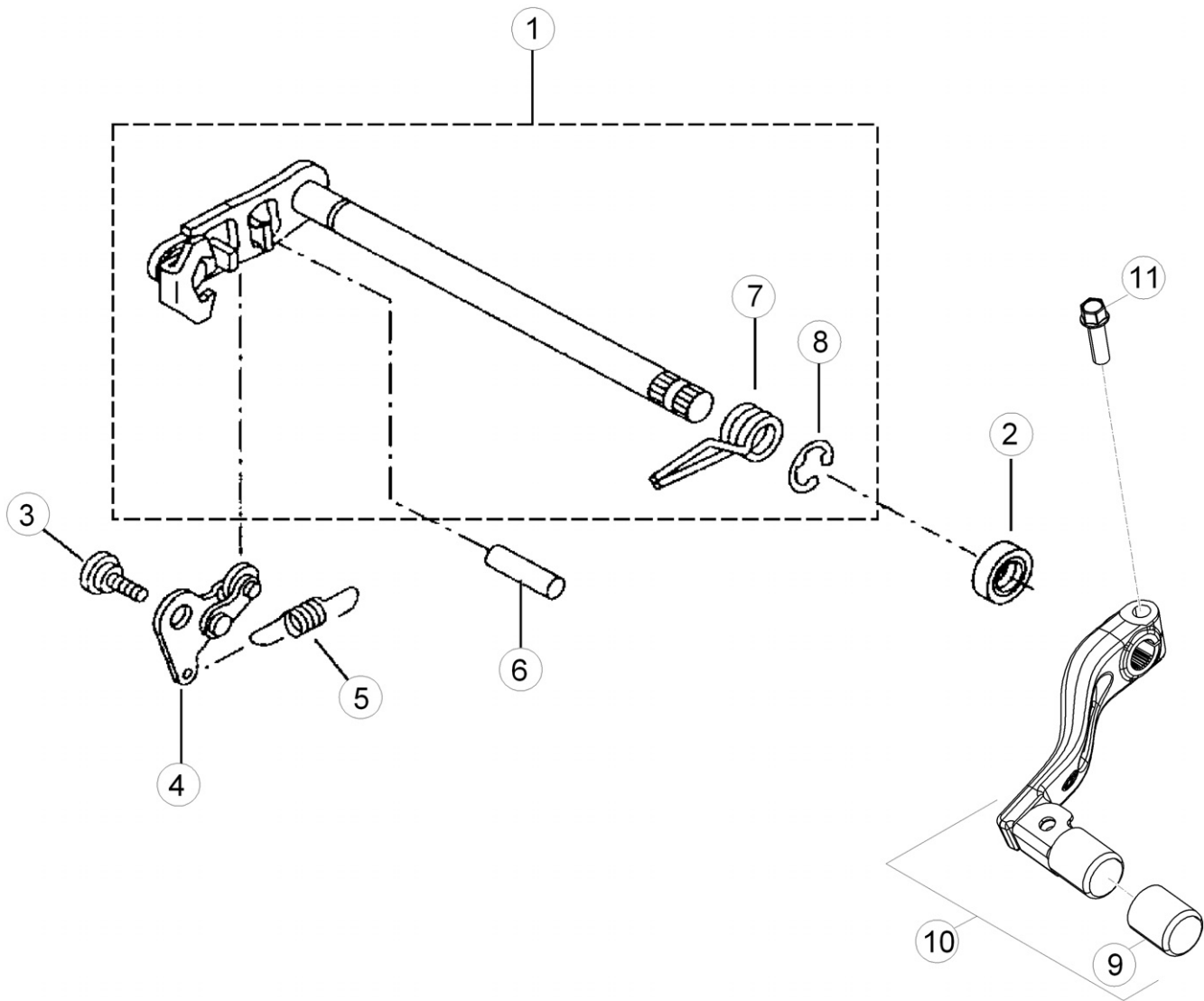

Pos Loc Pos Ps Pos	Numero Number Numéro Número Nummer	Q.tà Q.ty Q.té M.ge C.ad	Nota Note Note Nota Anm.	Descrizione	Description	Désignation	Beschreibung	Descripcìon
1	021.05.007.00.00	1		Albero selettore completo	Selector shaft, assy	Arbre sélection complet	Welle Schaltschiene komplett	Eje selector completo
2	021.05.008.00.00	1		Paraolio D.12x22x5	Oil seal D.12x22x5	Pare-huile D.12x22x5	Dichtring D.12x22x5	Sello de lub. D.12x22x5
3	021.05.009.00.00	1		Vite fiss. piastrina M6X1	Plate fastening screw M6X1	Vis de fixation plaquette M6X1	Befestigungsschraube M6X1	Tornillo fijación placa M6X1
4	021.05.010.00.00	1		Piastrina fermo selettore	Lock selector plate	Plaquette arret sélecteur	Plättchen schaltwelle fest	Placa parada selector
5	021.05.011.00.00	1		Molla selettore 1,4	Spring gear selector 1,4	Ressort sélecteur 1,4	Feder Schaltaut. 1,4	Muelle selector 1,4
6	021.05.012.00.00	1		Spina riferimento	Dowel	Goujon référence	Markierungsstift	Púa de referencia
7	021.05.013.00.00	1		Molla albero selettore	Selector shaft spring	Ressort arbre sélection	Feder Welle Schaltschiene	Meulle eje selector
8	021.05.014.00.00	1		Anello seeger D.10	Snap ring D.10	Circlips D.10	Seegerring D.10	Anillo seeger D.10
9	16.29590.000	1		Gommino	Rubber buffer	Caoutchouc	Gummi	Goma
10	021.05.000.80.00	1		Leva cambio	Gear change lever	Levier comm. chang. vit.	Schalthebel	Palanca cambio
11	11.49070.000	1		Bullone 6x20 ch rs	Bolt 6x20 ch rs	Boulon 6x20 ch rs	Bolzen 6x20 ch rs	Tornillo 6x20 ch rs

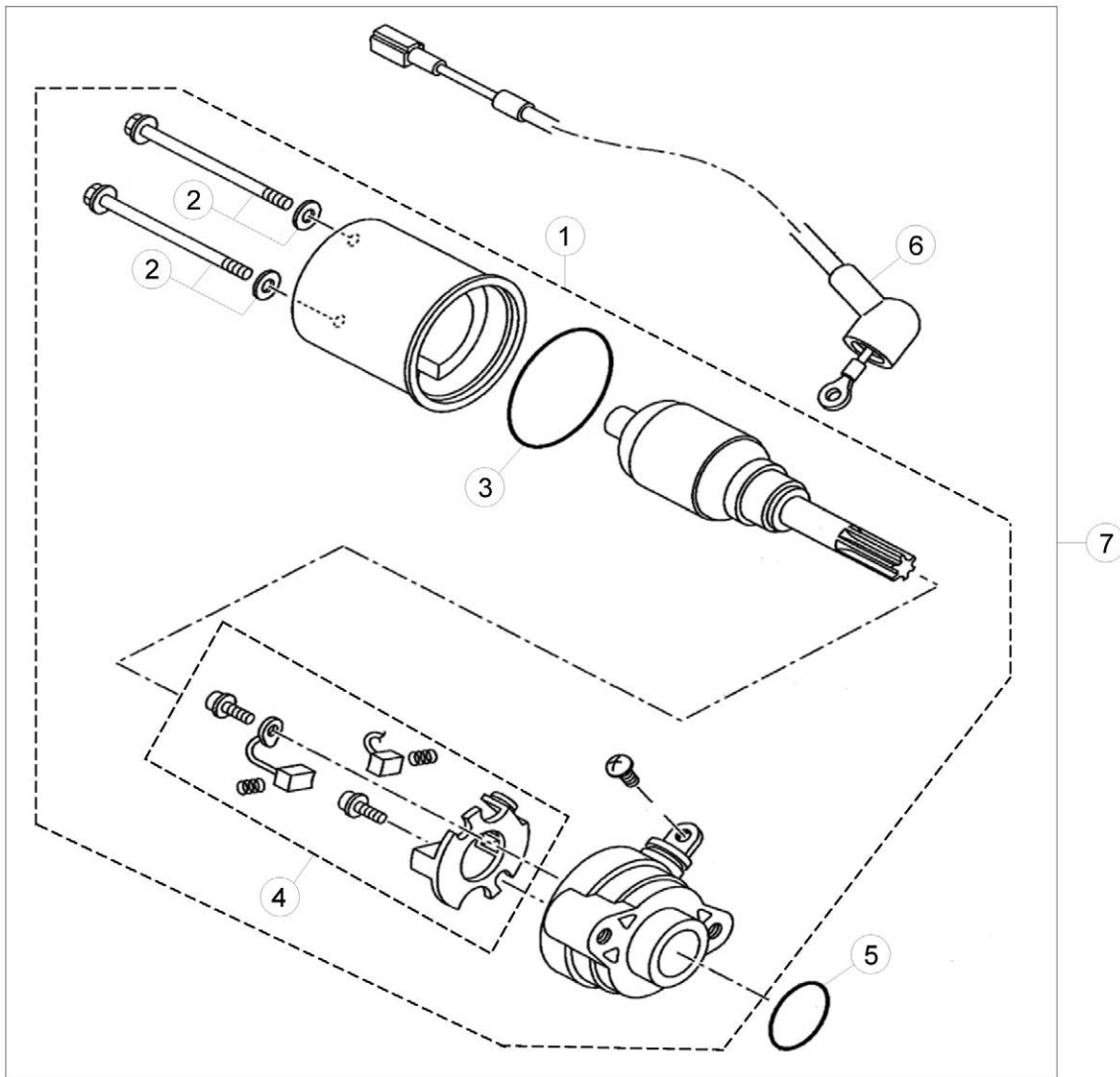

Pos Loc Pos Ps Pos	Numero Number Numéro Número Nummer	Q.tà Q.ty Q.té M.ge C.ad	Nota Note Note Nota Anm.	Descrizione	Description	Désignation	Beschreibung	Descripcìon
1	021.07.000.00.00	1		Motorino avviamento	Starter motor	Moteur du démarreur	Startermotor	Motor de arranque
2	021.07.001.00.00	2		Vite	Screw	Vis	Schraube	Tornillo
3	021.07.002.00.00	1		Anello di tenuta	Oil seal	Joint spie	Dichtring	Retén de aceite
4	021.07.003.00.00	1		Kit spazzole	Brushes kit	Kit brosses	Bausatz Bürsten	Kit escobillas
5	021.07.004.00.00	1		Anello di tenuta D.25,5x2,4	Oil seal D.25,5x2,4	Joint spie D.25,5x2,4	Dichtring D.25,5x2,4	Retén de aceite D.25,5x2,4
6	021.07.005.00.00	1		Cablaggio motorino avviamento	Starter motor wiring	Câblage moteur du démarreur	Startermotorkabelung	Cableado motor de arranque
7	021.07.006.00.00	1		Motorino di avviamento con cablaggio	Starter motor with wiring	Moteur du démarreur avec câblage	Startermotor mit kabelung	Motor de arranque con cableado

Tav.07A

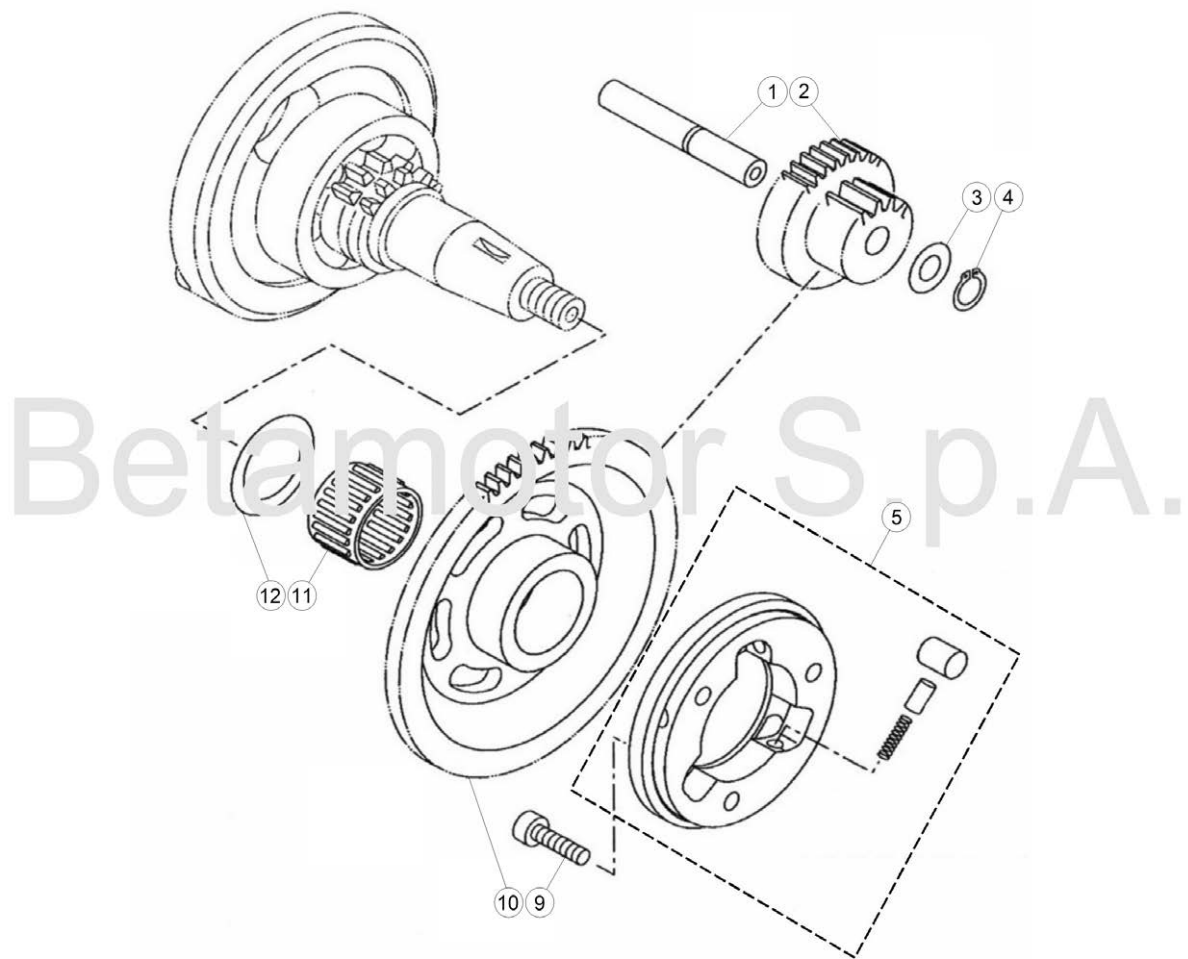

© Copyright 2018 Betamotor S.p.A.

Pos Loc Pos Ps Pos	Numero Number Numéro Número Nummer	Q.tà Q.ty Q.té M.ge C.ad	Nota Note Note Nota Anm.	Descrizione	Description	Désignation	Beschreibung	Descripció
1	021.07.007.00.00	1		Perno ingranaggio intermedio	Intermediate gear pin	Axe engrenage intermédiaire	Zahnradzwischenstift	Perno engranaje intermedio
2	021.07.020.00.00	1		Ingranaggio	Gear	Engrenage	Getriebe	Engranaje
3	021.07.009.00.00	1		Rondella piana D.10,2x18x1	Plain washer D.10,2x18x1	Rondelle plate D.10,2x18x1	U.Scheibe D.10,2x18x1	Arandela plana D.10,2x18x1
4	021.07.010.00.00	1		Anello seeger D.10	Snap ring D.10	Circlips D.10	Seegerring D.10	Anillo seeger D.10
5	021.07.011.00.00	1		Ruota libera	Free wheel	Roue libre	Freilauf	Rueda libre
9	31.31050.000	5		Vite t.c.c.e. M6x16 bianca c/frenafilletti	Screw t.c.c.e. M6x16 white w/threadlocker	Vis t.c.c.e. M6x16 blanc avec frein filet	Schraube t.c.c.e. M6x16 weiss mit Schraubensicherung	Tornillo t.c.c.e. M6x16 blanco con fijador de roscas
10	021.07.016.00.00	1		Ingranaggio condotto avviamento	Starter driven gear	Engrenage entraîné démarrage	Angetriebenes Zahnrad für Anlaß	Engranaje conducido arranque
11	021.07.017.00.00	1		Gabbia a rulli D. 25x30x19,8	Roller cage D. 25x30x19,8	Cage a roul. D. 25x30x19,8	Rollenkäfig D. 25x30x19,8	Jaula de rod. D. 25x30x19,8
12	021.07.018.00.00	1		Rondella piana D.25,2X36X1	Plain washer D.25,2X36X1	Rondelle plate D.25,2X36X1	U.Scheibe D.25,2X36X1	Arandela plana D.25,2X36X1

Tav.08

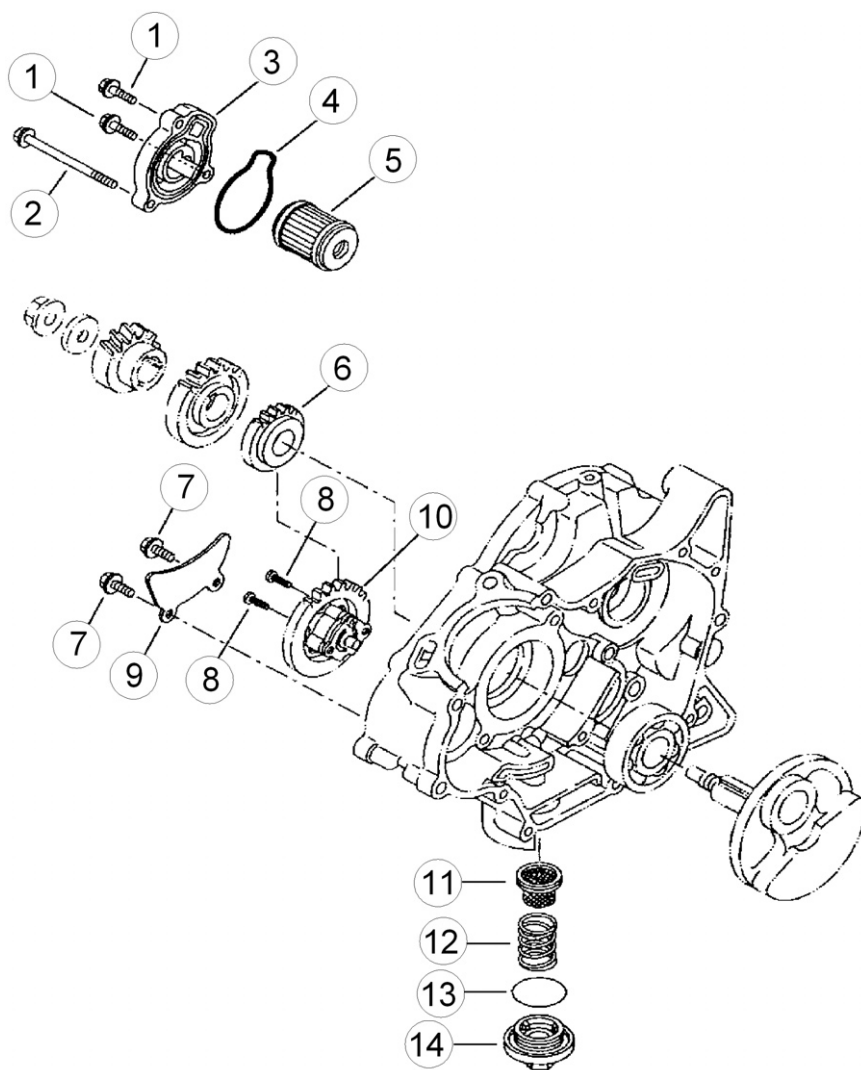

Pos Loc Pos Ps Pos	Numero Number Numéro Número Nummer	Q.tà Q.ty Q.té M.ge C.ad	Nota Note Note Nota Anm.	Descrizione	Description	Désignation	Beschreibung	Descripció
1	021.09.019.00.00	2		Vite TE FLG M6x20	Screw TE FLG M6x20	Vis TE FLG M6x20	Schraube TE FLG M6x20	Tornillo TE FLG M6x20
2	021.08.001.00.00	1		Vite TE M6x80	Screw TE M6x80	Vis TE M6x80	Schraube TE M6x80	Tornillo TE M6x80
3	021.08.014.00.00	1		Coperchio filtro olio	Oil filter cover	Couvercle filtre à huile	Ölfiltergehäuse	Tapa filtro de aceite
4	021.08.003.00.00	1		Anello di tenuta D.53,6x2,4	Oil seal D.53,6x2,4	Joint spie D.53,6x2,4	Dichtring D.53,6x2,4	Retén de aceite D.53,6x2,4
5	021.08.004.00.00	1		Filtro olio completo	Oil filter, assy	Filtre à huile complet	Ölfilter kepl	Filtro de aceite completo
6	021.08.015.00.00	1		Ingranaggio pompa olio	Pump oil gear	Engrenage huile pompe	Getriebe zur Pumpenölleitung	Engranaje bomba aceite
7	021.08.006.00.00	2		Vite TE M6x12	Screw TE M6x12	Vis TE M6x12	Schraube TE M6x12	Tornillo TE M6x12
8	021.08.007.00.00	2		Vite T.C.B. M5x25	Screw T.C.B. M5x25	Vis T.C.B. M5x25	Schraube T.C.B. M5x25	Tornillo T.C.B. M5x25
9	021.08.008.00.00	1		Coperchio ingranaggio pompa olio	Oil pump gear cover	Couvercle engrenage pompe huile	Deckel zahnrad Ölpumpe	Tapa engranaje bomba aceite
10	021.08.009.00.00	1		Pompa olio completa	Oil pump assembly	Pompe à huile complète	Ölpumpe komplett	Bomba del aceite completa
11	021.08.010.00.00	1		Filtro olio	Oil filter	Filtre à huile	Ölfilter	Filtro de aceite
12	021.08.011.00.00	1		Molla	Spring	Ressort	Feder	Muelle
13	021.08.012.00.00	1		Anello di tenuta D.35,7x3,5	Oil seal D.35,7x3,5	Joint spie D.35,7x3,5	Dichtring D.35,7x3,5	Retén de aceite D.35,7x3,5
14	021.08.013.00.00	1		Tappo scarico olio	Oil exh. plug	Bouchon dech. huile	Ölablassschraube	Tapón de descarga aceite

Tav.09

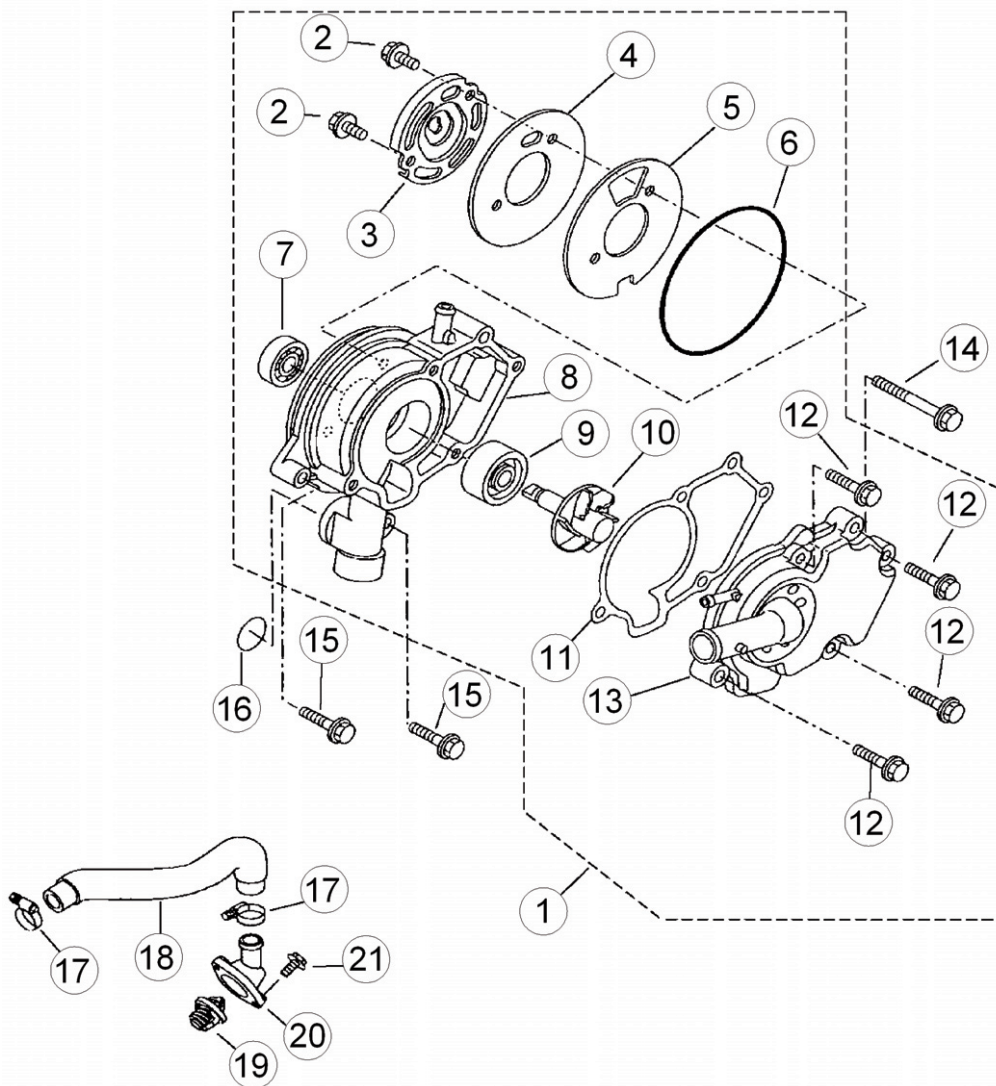

Pos Loc Pos Ps Pos	Numero Number Numéro Número Nummer	Q.tà Q.ty Q.té M.ge C.ad	Nota Note Note Nota Anm.	Descrizione	Description	Désignation	Beschreibung	Descripció
1	021.09.000.00.00	1		Pompa acqua completa	Water pump, assy	Pompe à eau	Wasserpumpe	Bomba de agua compl.
2	021.09.020.00.00	2		Vite	Screw	Vis	Schraube	Tornillo
3	021.09.002.00.00	1		Piastra arresto	Stop plate	Plaque butee	Anschlagplatte	Placa de tope
4	021.09.003.00.00	1		Piastra coperchio pompa	Pump cover plate	Plaque cCouvercle pompe	Pumpendeckel platte	Placa tapa bomba
5	021.09.004.00.00	1		Guarnizione piastra	Gasket, Plate	Joint Plaque	Dichtpl. Gassch. Fcr-Mx	Junta Placa Valvula
6	021.09.005.00.00	1		Anello di tenuta D.1,9x84	Oil seal D.1,9x84	Joint spie D.1,9x84	Dichtring D.1,9x84	Retén de aceite D.1,9x84
7	021.09.006.00.00	1		Cuscinetto a sfere D.10x26x8	Ball bearing D.10x26x8	Roulement à billes D.10x26x8	Kugellager D.10x26x8	Cojinete de bolas D.10x26x8
8	021.09.007.00.00	1		Corpo pompa acqua	Water pump plunger cylinder	Cylindre de plongeur de pompe eau	Wasserpumpengehäuse	Cuepo bomba agua
9	021.09.008.00.00	1		Paraolio D.10X31X13,5	Oil seal D.10X31X13,5	Pare-huile D.10X31X13,5	Dichtring D.10X31X13,5	Sello de lub. D.10X31X13,5
10	021.09.009.00.00	1		Girante pompa acqua	Water pump fan	Couronne pompe eau	Läuferrad der Wasserpumpe	Rotor bomba agua
11	021.09.010.00.00	1		Guarnizione coperchio pompa acqua	Water pump cover gasket	Joint couvercle pompe eau	Dichtung Wasserpumpeabdeckung	Junta tapa bomba agua
12	021.09.011.00.00	4		Vite TE M6x25	Screw TE M6x25	Vis TE M6x25	Schraube TE M6x25	Tornillo TE M6x25
13	021.09.012.00.00	1		Coperchio pompa acqua	Water pump cover	Couvercle pompe à eau	Wasserpumpendeckel	Tapa bomba agua
14	021.01.010.00.00	1		Vite TE M6x50	Screw TE M6x50	Vis TE M6x50	Schraube TE M6x50	Tornillo TE M6x50
15	021.09.013.00.00	2		Vite TE M6x25	Screw TE M6x25	Vis TE M6x25	Schraube TE M6x25	Tornillo TE M6x25
16	021.09.014.00.00	1		Anello di tenuta D.19X2,4	Oil seal D.19X2,4	Joint spie D.19X2,4	Dichtring D.19X2,4	Retén de aceite D.19X2,4
17	021.09.015.00.00	2		Fascetta	Clamp	Collier	Schelle	Abrazadera
18	021.39.008.00.00	1		Tube termostato-radiatore dx	Thermostat-radiator pipe, r.h.	Tuyau thermostat-radiateur dr.	Schlauch Thermostat- Kühler r.	Tube termostato-radiador der.
19	021.09.017.00.00	1		Termostato	Bimetal, thermostatic	Thérmostat	Thermostat	Termostato
20	021.09.018.00.00	1		Coperchio termostato	Thermostat cover	Couvercle du thermostat	Thermostatabdeckung	Tapa del termostato
21	021.09.019.00.00	1		Vite TE M6x20	Screw TE M6x20	Vis TE M6x20	Schraube TE M6x20	Tornillo TE M6x20

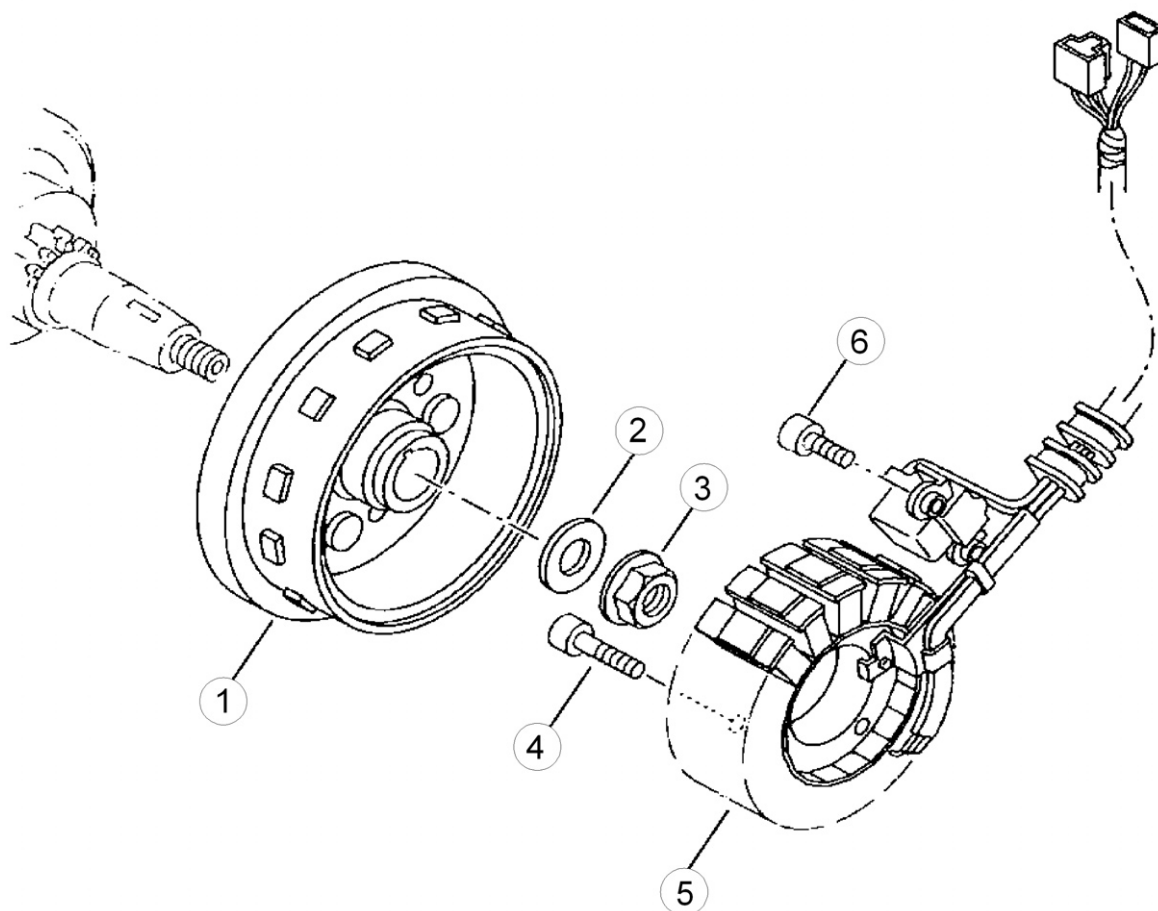

Pos	Numero	Q.tà	Nota	Descrizione	Description	Désignation	Beschreibung	Descripcìon
Loc	Number	Q.ty	Note					
Pos	Numéro	Q.té	Note					
Ps	Número	M.ge	Nota					
Pos	Nummer	C.ad	Anm.					
1	021.10.000.00.00	1		Rotore volano	Flywheel rotor	Rotor volant	Rotor schwungrad	Rotor volante
2	021.03.028.00.00	1		Rondella piana D.12,2x30x3	Plain washer D.12,2x30x3	Rondelle plate D.12,2x30x3	U.Scheibe D.12,2x30x3	Arandela plana D.12,2x30x3
3	021.10.001.00.00	1		Dado flangiato M12x1,25x11	Flanged nut M12x1,25x11	Ecrou bordé M12x1,25x11	Flanschmutter M12x1,25x11	Tuerca embreada M12x1,25x11
4	021.10.002.00.00	3		Vite t.c.c.e. M6x25	Screw t.c.c.e. M6x25	Vis t.c.c.e. M6x25	Schraube t.c.c.e. M6x25	Tornillo t.c.c.e. M6x25
5	021.10.003.00.00	1		Statore volano	Alternator stator	Stator volant	Stator schwungrad	Placa del volante
6	31.31050.000	2		Vite t.c.c.e. M6x16	Screw t.c.c.e. M6x16	Vis t.c.c.e. M6x16	Schraube t.c.c.e. M6x16	Tornillo t.c.c.e. M6x16

Tav.11

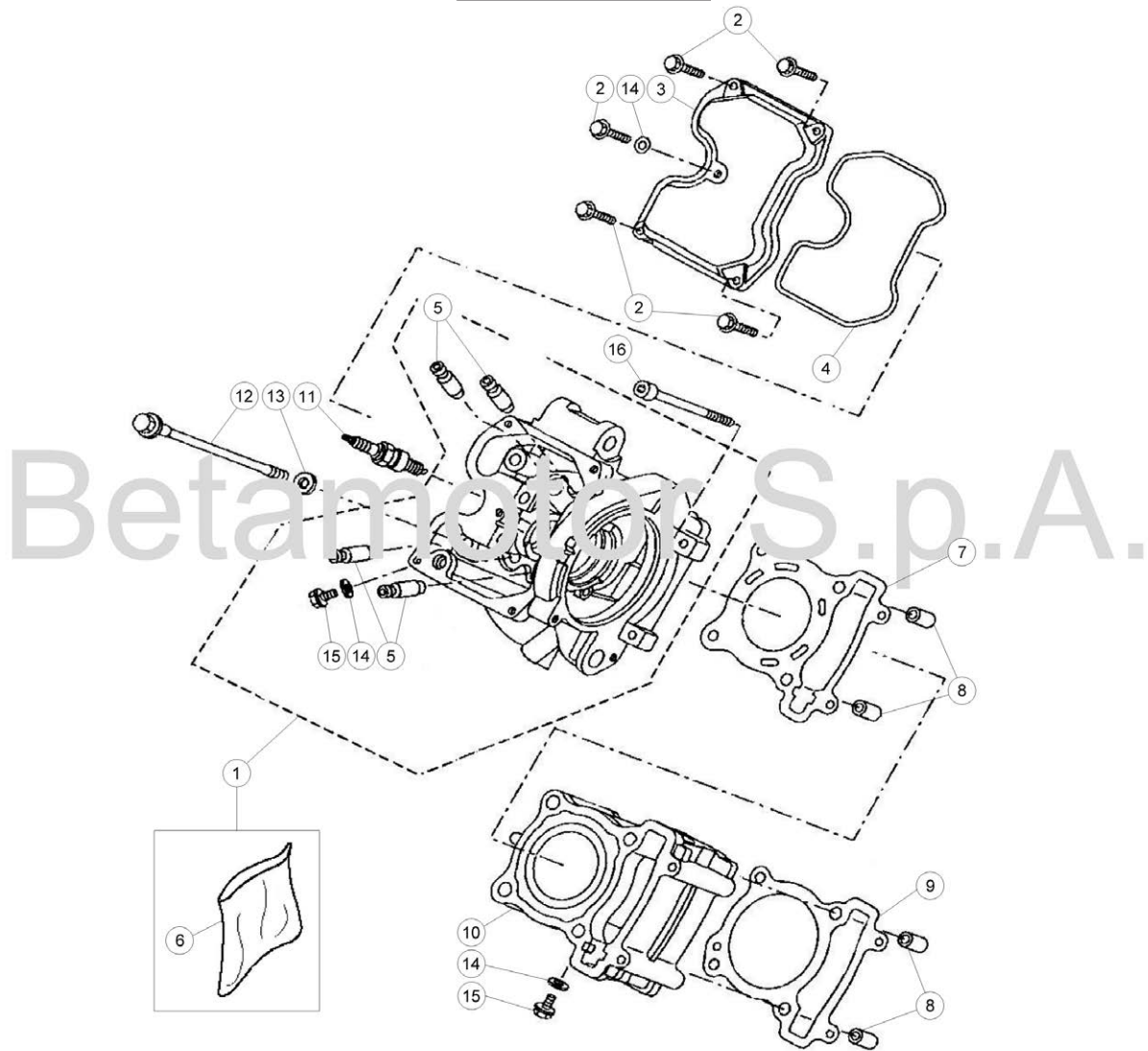

© Copyright 2016 Betamotor S.p.A.

Pos Loc Pos Ps Pos	Numero Number Numéro Número Nummer	Q.tà Q.ty Q.té M.ge C.ad	Nota Note Note Nota Anm.	Descrizione	Description	Désignation	Beschreibung	Descripció
1	021.11.048.00.00	1		Testa completa	Cylinder head	Culasse complete	Zylinderkopf Kpl.	Culata completa
2	021.09.019.00.00	5		Vite TE M6x20	Screw TE M6x20	Vis TE M6x20	Schraube TE M6x20	Tornillo TE M6x20
3	021.11.001.00.00	1		Coperchio testa	Cylinder head cover	Couvercle culasse	Zylinderkopfdeckung	Tapa culata
4	021.11.002.00.00	1		Anello di tenuta D.2,9	Oil seal D.2,9	Joint spie D.2,9	Dichtring D.2,9	Retén de aceite D.2,9
5	021.11.003.00.00	4		Guida valvola	Valve guide	Guide soupape	Ventilführung	Guía válvula
6	021.11.004.00.00	2		Prigioniero M8x36	Stud M8x36	Goujon M8x36	Stiftschraube M8x36	Espárrago M8x36
7	021.11.005.00.00	1		Guarnizione testa SP.0,2	Cylinder head gasket SP.0,2	Joint Culasse SP.0,2	Zylinderkopfichtung SP.0,2	Junta de culata SP.0,2
8	021.01.001.00.00	8		Grano di riferimento D.10x14-INT.D.8,5	Dowel D.10x14-INT.D.8,5	Repère D.10x14-INT.D.8,5	Passstift D.10x14-INT.D.8,5	Centraje D.10x14-INT.D.8,5
9	021.11.006.00.00	1		Guarnizione base cilindro	Cylinder base gasket	Garniture base cylindre	Dichtung für Zylinderfuß	Junta base cilindro
10	021.11.007.00.00	1		Cilindro D.52	Cylinder D.52	Cylindre D.52	Zylinder D.52	Cilindro D.52
11	021.11.008.00.00	1		Candela NGK CR8E	Spark plug NGK CR8E	Bougie NGK CR8E	Zündkerze NGK CR8E	Bujía NGK CR8E
12	021.11.009.00.00	4		Vite flangiata M8X175	Flange bolt M8X175	Boulon de bride M8X175	Flanschschraube M8X175	Perno de reborde M8X175
13	021.11.047.00.00	4		Rondella	Washer	Rondelle	U.Scheibe	Arandela
14	021.11.011.00.00	3		Rondella in rame D. 6,3x13x1,2	Copper washer D. 6,3x13x1,2	Rondelle en cuivre D. 6,3x13x1,2	Kupfer U.Scheibe D. 6,3x13x1,2	Arandela de cobre D. 6,3x13x1,2
15	021.11.012.00.00	2		Vite TE M6x10	Screw TE M6x10	Vis TE M6x10	Schraube TE M6x10	Tornillo TE M6x10
16	021.11.013.00.00	2		Vite tcce M6x100	Screw tcce M6x100	Vis tcce M6x100	Schraube tcce M6x100	Tornillo tcce M6x100

Tav.11A

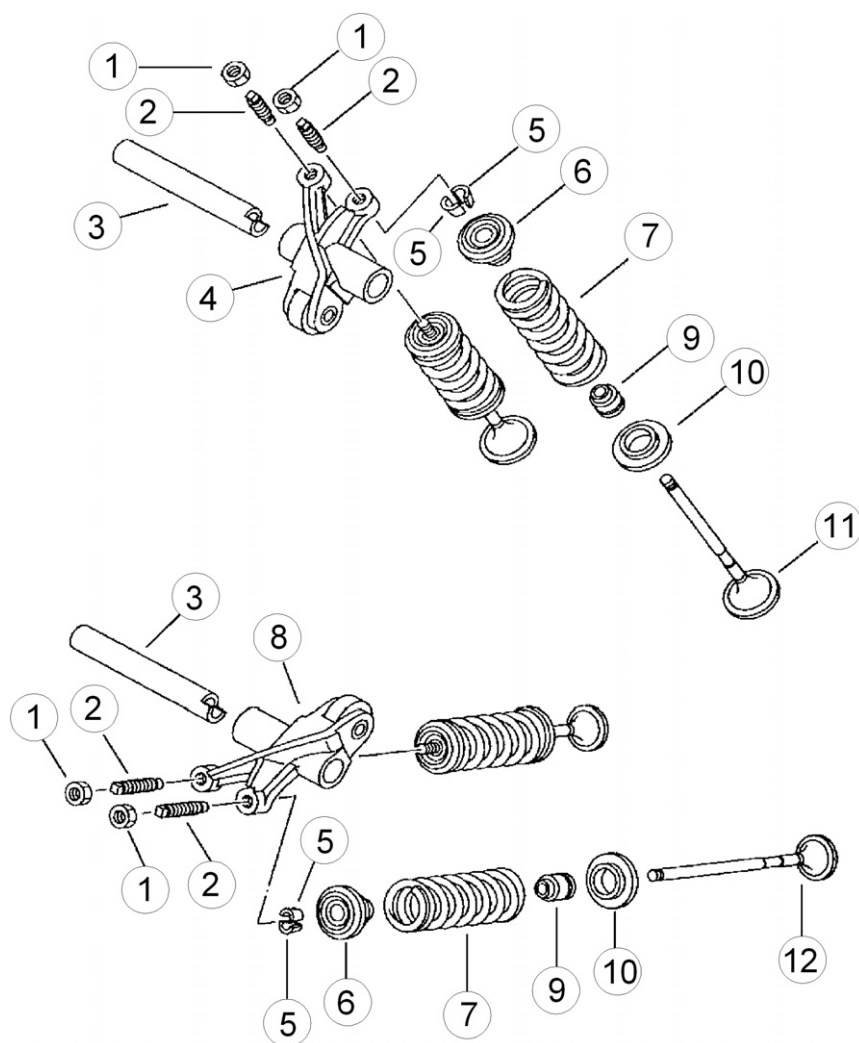

Pos	Numero	Q.tà	Nota	Descrizione	Description	Désignation	Beschreibung	Descripcìon
Loc	Number	Q.ty	Note					
Pos	Numéro	Q.té	Note					
Ps	Número	M.ge	Nota					
Pos	Nummer	C.ad	Anm.					
1	021.11.014.00.00	4		Dado M5X0,5 CH=8	Nut M5X0,5 CH=8	Ecrou M5X0,5 CH=8	Mutter M5X0,5 CH=8	Tuerca M5X0,5 CH=8
2	021.11.015.00.00	4		Vite registro valvola gas	Throttle adj. screw	Vis réglage papillons	Drosseleinstellschraube	Tornillo
3	021.11.016.00.00	2		Perno bilanciare D.10x66	Rocker shaft D.10x66	Axe culbuteur D.10x66	Kipphebel-Federwelle D.10x66	Eje balancín D.10x66
4	021.11.017.00.00	1		Bilanciere aspirazione	Suction lever	Balancier aspir.	Einlaßkipphebel	Balancin aspiración
5	021.11.018.00.00	8		Anello ritegno	Circlip	Circlips	Ring zur Befest. der Zapfen	Reten de ac.
6	021.11.019.00.00	4		Scodellino superiore	Upper stop washer	Rondelle d'arrêt supérieure	Oberer Federaufnahme	Platillo superior
7	021.11.020.00.00	4		Molla valvola	Valve spring	Ressort soupape	Ventilfeder	Muelle válvula
8	021.11.021.00.00	1		Bilanciere scarico	Exhaust lever	Balancier d'éch.	Auslaßkipphebel	Balancin de escape
9	021.11.022.00.00	4		Anello di tenuta D.4,5x9,5X8	Oil seal D.4,5x9,5X8	Joint spie D.4,5x9,5X8	Dichtring D.4,5x9,5X8	Retén de aceite D.4,5x9,5X8
10	021.11.023.00.00	4		Scodellino inferiore	Lower stop washer	Rondelle d'arrêt inférieure	Unterer Federaufnahme	Platillo inferior
11	021.11.024.00.00	2		Valvola di aspirazione D.19,5	Valve, in D.19,5	Soupape d'admission D.19,5	Ein. Ventil D.19,5	Valvula de admision D.19,5
12	021.11.025.00.00	2		Valvola di scarico D.17	Exhaust valve D.17	Soupape d'échapp. D.17	Auslassventil D.17	Válvula de descarga D.17

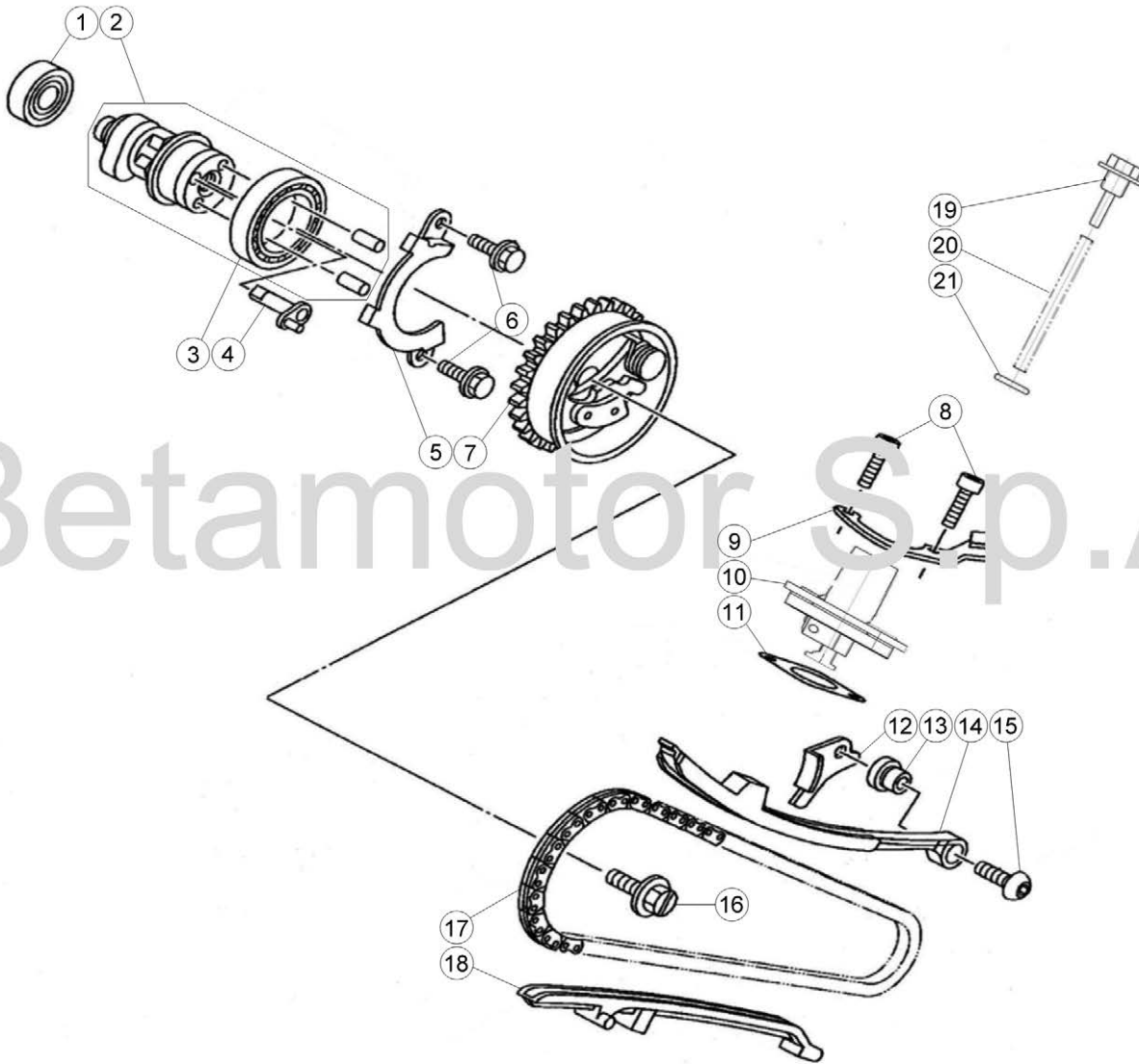

© Copyright 2017 Betamotor S.p.A.

Pos Loc Pos Ps Pos	Numero Number Numéro Número Nummer	Q.tà Q.ty Q.té M.ge C.ad	Nota Note Note Nota Anm.	Descrizione	Description	Désignation	Beschreibung	Descripción
1	021.11.026.00.00	1		Cuscinetto D.12x28x8	Bearing D.12x28x8	Roulement D.12x28x8	Lager D.12x28x8	Cojinete D.12x28x8
2	021.11.027.00.00	1		Albero A Camme Completo	Complete Camshaft	Arbre à Cames Complet	Komplette Nockenwelle	Árbol de Levas Completo
3	021.11.028.00.00	1		Cuscinetto D.30x47x9	Bearing D.30x47x9	Roulement D.30x47x9	Lager D.30x47x9	Cojinete D.30x47x9
4	021.11.029.00.00	1		Albero Di Decompressione	Decompression Shaft	Arbre Decompression	Dekowelle	Ciguenal De Decompression
5	021.11.030.00.00	1		Piastrina bloccaggio SP.1,2	Locking plate SP.1,2	Plaque serrage SP.1,2	Blockiervorrichtung SP.1,2	Placa fijación SP.1,2
6	021.04.019.00.00	2		Vite TE M6x10	Screw TE M6x10	Vis TE M6x10	Schraube TE M6x10	Tornillo TE M6x10
7	021.11.031.00.00	1		Corona distribuzione	Timing gear	Couronne distribution	Zahnkranz Ventilsteuerung	Corona distribución
8	021.09.019.00.00	2		Vite TE M6x20 zn bianca	Screw TE M6x20 zn white	Vis TE M6x20 zn blanc	Schraube TE M6x20 zn weiss	Tornillo TE M6x20 zn blanco
9	021.11.033.00.00	1		Passacavo trasmissione frizione	Clutch transmission grommet	Passe-câble transmission embrague	Kabeldurchgang Kupplung	Pasacables transmisión embrague km.
10	021.11.043.00.00	1		Cilindro tenditore	Tensioner cylinder	Cylindre tendeur de ch.	Zylinder Kettenspanner	Cilindro tensor cadena
11	021.11.035.00.00	1		Guarnizione tendicatena	Chain tightener gasket	Joint tend. de ch.	Kettenspannerdichtung	Junta tens. de cad.
12	021.11.036.00.00	1		Coperchio catena	Chain cover	Couvercle chaîne	Abdeckung Verteilerkette	Tapa catena
13	021.11.037.00.00	1		Distanziale	Spacer	Entretoise	Distanzstück	Distanciador
14	021.11.038.00.00	1		Guidacatena	Chain guide	Guide-Chaîne	Kettenführung	Guia catena
15	021.11.039.00.00	1		Vite TBCE M6x1x20	Screw TBCE M6x1x20	Vis TBCE M6x1x20	Schraube TBCE M6x1x20	Tornillo TBCE M6x1x20
16	021.11.040.00.00	1		Vite TE M8x1,25 CH=12	Screw TE M8x1,25 CH=12	Vis TE M8x1,25 CH=12	Schraube TE M8x1,25 CH=12	Tornillo TE M8x1,25 CH=12
17	021.11.041.00.00	1		Catena distribuzione	Timing chain	Chaîne de distribution	Ventilsteuerkette	Cadena distribución
18	021.11.042.00.00	1		Guidacatena	Chain guide	Guide-Chaîne	Kettenführung	Guia catena
19	021.11.045.00.00	1		Vite tenditore	Tensioner screw	Vis tendeur de ch.	Schraube Kettenspanner	Tornillo tensor cadena
20	021.11.044.00.00	1		Molla tenditore	Tensioner spring	Ressort tendeur de ch.	Feder Kettenspanner	Muelle tensor cadena
21	021.11.046.00.00	1		Anello di tenuta	Oil seal	Joint spie	Dichtring	Retén de aceite

Tav.12

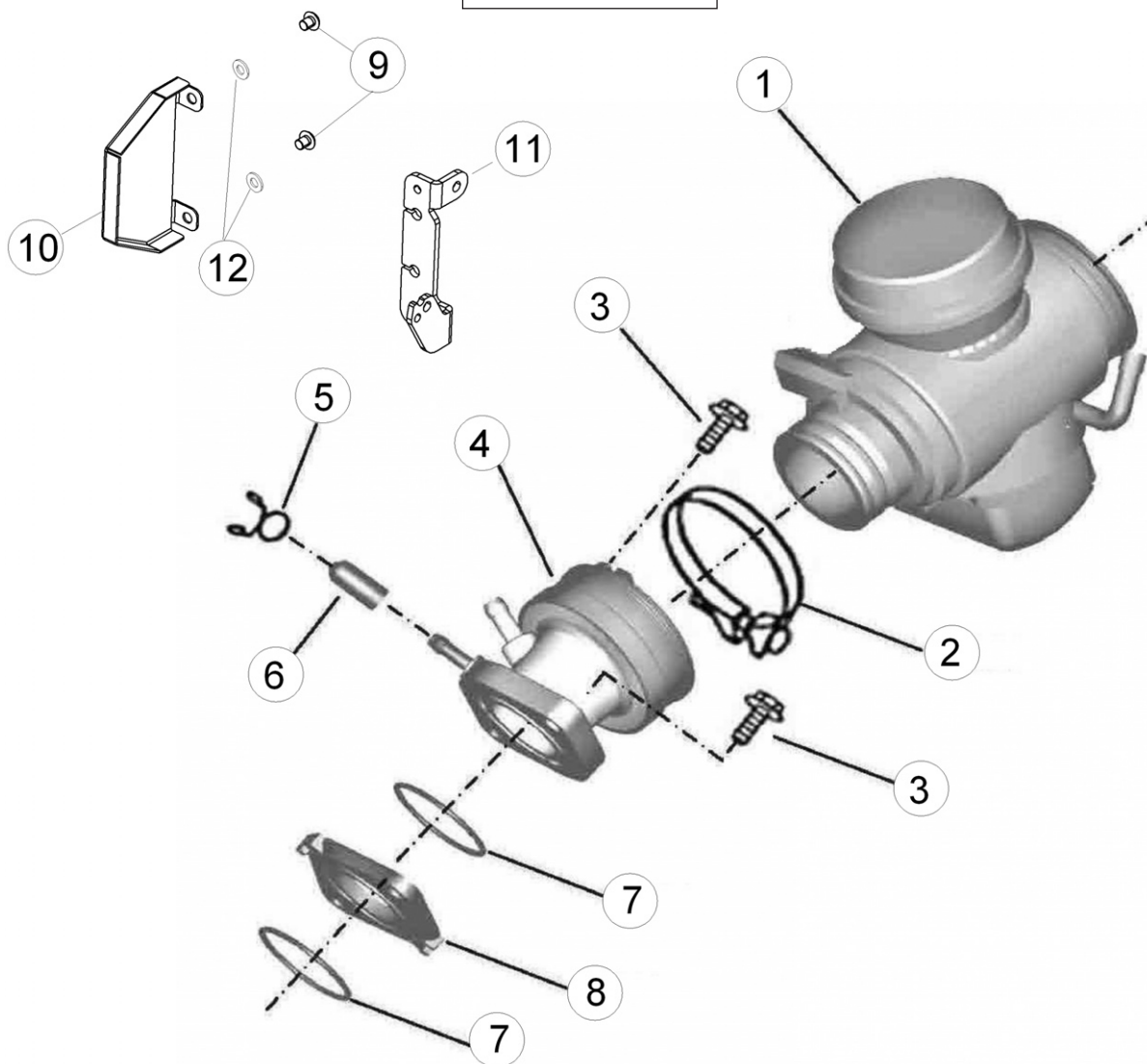

Pos Loc Pos Ps Pos	Numero Number Numéro Número Nummer	Q.tà Q.ty Q.té M.ge C.ad	Nota Note Note Nota Anm.	Descrizione	Description	Désignation	Beschreibung	Descrìcion
1	021.12.000.80.00	1		Carburatore KEIHIN D.29	Carburettor KEIHIN D.29	Carbureteur KEIHIN D.29	Vergaser KEIHIN D.29	Carburador KEIHIN D.29
2	021.12.003.00.00	1		Fascetta D.52	Clamp D.52	Collier D.52	Schelle D.52	Abrazadera D.52
3	021.12.004.00.00	2		Vite t.c.c.e. M6X25	Screw t.c.c.e. M6X25	Vis t.c.c.e. M6X25	Schraube t.c.c.e. M6X25	Tornillo t.c.c.e. M6X25
4	021.12.005.00.00	1		Collettore	Manifold	Collecteur	Anschlußstück	Colector
5	021.12.006.00.00	1		Clip	Clip	Clip	Clip	Clip
6	021.12.007.00.00	1		Tappo in gomma	Rubber cap	Bouchon en caoutchouc	Gummiverschluß	Tapón de goma
7	021.12.008.00.00	2		Anello di tenuta D.32,2x2	Oil seal D.32,2x2	Joint spie D.32,2x2	Dichtring D.32,2x2	Retén de aceite D.32,2x2
8	021.12.009.00.00	1		Distanziale	Spacer	Entretoise	Distanzstück	Distancidor
9	11.46100.000	2		Bullone M5x8	Bolt M5x8	Boulon M5x8	Bolzen M5x8	Tornillo M5x8
10	021.12.002.00.05	1		Coperchio carburatore	Carburettor cover	Couvercle carburateur	Abdeckung Vergaser	Tapa carburador
11	021.12.001.00.05	1		Supporto carburatore	Carburettor support	Support carburateur	Hälter für vergaser	Soporte carburador
12	27.36000.000	2		Rondella 5x11	Washer 5x11	Rondelle 5x11	U.Scheibe 5x11	Arandela 5x11

Tav.12A

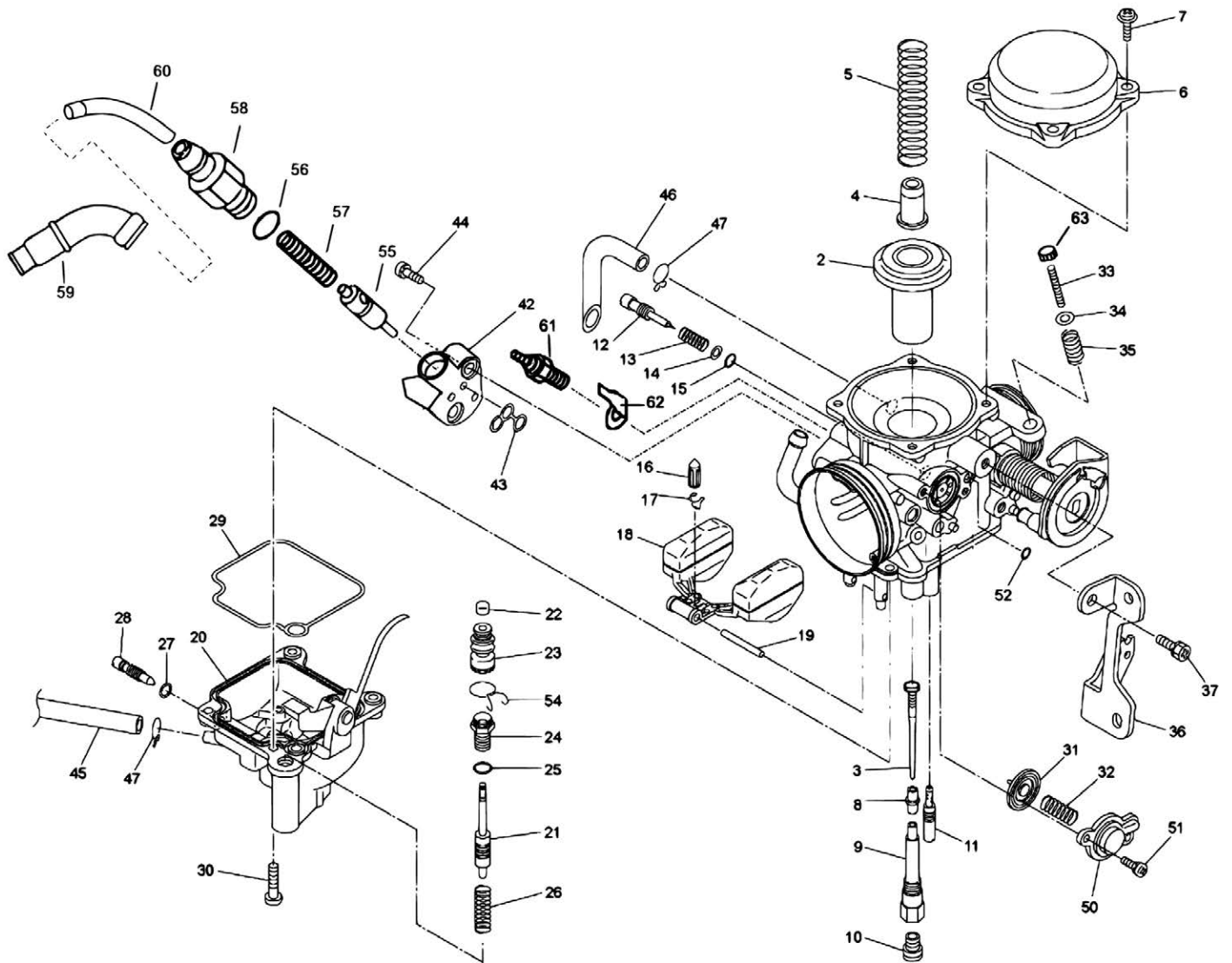

Tav.12A

Pos Loc Pos Ps Pos	Numero Number Numéro Número Nummer	Q.tà Q.ty Q.té M.ge C.ad	Nota Note Note Nota Anm.	Descrizione	Description	Désignation	Beschreibung	Descripción
2	021.12.010.00.00	1		Pistone completo	Piston set	Piston compl.	Kolben, kompl.	Pistón, compl.
3	021.12.011.00.00	1		Spillo	Needle	Pointeau	Düsennadel	Aguja
4	021.12.012.00.00	1		Sede molla	Seat, spring	Siege ressort	Sitz, feder	Asiento resorte
5	021.12.013.00.00	1		Molla	Spring	Ressort	Feder	Muelle
6	021.12.014.00.00	1		Coperchio	Cover	Couvercle	Deckel	Tapa
7	021.12.015.00.00	4		Vite	Screw	Vis	Schraube	Tornillo
8	021.12.016.00.00	1		Getto spillo	Needle jet	Gicleur d'aiguille	Nadeldüse	Surtidor
9	021.12.017.00.00	1		Sede getto spillo	Needle jet seat	Siege gicleur d'aiguille	Nadeldüsesitz	Asiento del surtidor
10	021.12.018.00.00	1		Getto massimo	Main jet	Gicleur maxi	Hauptdüse	Surtidor máximo
11	021.12.019.00.00	1		Getto minimo	Starter jet	Gicleur starter	Starterdüse	Surtidor starter
12	021.12.020.00.00	1		Vite reg. min.	Adjusting screw	Vis de réglage	Schraube, Einstell	Tornillo de regul.
13	021.12.021.00.00	1		Molla	Spring	Ressort	Feder	Muelle
14	021.12.022.00.00	1		Rondella	Washer	Rondelle	U.Scheibe	Arandela
15	021.12.023.00.00	1		Anello OR	O-Ring	Bague d'étanchéité	O-Ring	Anillo OR
16	021.12.024.00.00	1		Valvola a spillo	Needle valve	Soupape à pointeau	Nadelventil	Válvula de aguja
17	021.12.025.00.00	1		Anello seeger	Snap ring	Circlips	Seegerring	Anillo seeger
18	021.12.026.00.00	1		Galleggiante	Float	Flotteur	Schwimmer	Flotador
19	021.12.027.00.00	1		Perno galleggiante	Float pin	Axe de flotteur	Schwimmerzapfen	Perno flotador
20	021.12.028.00.00	1		Camera galleggiante	Float Chamber	Flottant Carburateur	Schwimmergehäuse	Cama Flotante
21	021.12.029.00.00	1		Pistone	Piston	Piston	Kolben	Pistón
22	021.12.030.00.00	1		Collare	Clamp	Collier	Schelle	Abrazadera
23	021.12.031.00.00	1		Coperchio	Cover	Couvercle	Deckel	Tapa
24	021.12.032.00.00	1		Distanziale	Spacer	Entretoise	Distanzstück	Distanciator
25	021.12.033.00.00	1		Anello OR	O-Ring	Bague d'étanchéité	O-Ring	Anillo OR
26	021.12.034.00.00	1		Molla	Spring	Ressort	Feder	Muelle
27	021.12.035.00.00	1		Anello OR	O-Ring	Bague d'étanchéité	O-Ring	Anillo OR
28	021.12.036.00.00	1		Vite di drenaggio	Drain screw	Vis de purge	Ablaufschraube	Tornillo de purga
29	021.12.037.00.00	1		Guarnizione camera galleg. carb.	Carb Float Chamber Seal	Joint Chambre Flotteur Carburateur	Dichtung f. Schwimmerkam mer Vergaser	Junta Cámara Flotador Carb.
30	021.12.038.00.00	4		Vite	Screw	Vis	Schraube	Tornillo
31	021.12.039.00.00	1		Membrana	Diaphragm	Membrane	Membrane	Membrana
32	021.12.040.00.00	1		Molla	Spring	Ressort	Feder	Muelle
33	021.12.041.00.00	1		Vite d'arresto	Stop screw	Vis butee	Anschlag-schraube	Tornillo de tope
34	021.12.042.00.00	1		Rondella	Washer	Rondelle	U.Scheibe	Arandela
35	021.12.043.00.00	1		Molla	Spring	Ressort	Feder	Muelle
36	021.12.001.00.05	1		Piastra fissaggio	Thrust Plate	Plaque De Poussée	Druckplatte	Placa Empuje
37	021.12.045.00.00	1		Bullone con rondella	Bolt with washer	Boulon avec rondelle	Bolzen mit Unterlegscheibe	Tornillo con arandela
42	021.12.046.00.00	1		Corpo starter	Starter body	Corps starter	Starterkörper	Cuerpo starter
43	021.12.047.00.00	1		Anello OR	O-Ring	Bague d'étanchéité	O-Ring	Anillo OR
44	021.12.048.00.00	1		Vite con rondella	Screw with washer	Vis avec rondelle	Schraube und Unterlegscheibe	Tornillo con arandela
45	021.12.049.00.00	1		Tube in plastica	Plastic pipe	Tube plastique	Kunststoffrohr	Tube de plastico
46	021.12.050.00.00	1		Tube in plastica	Plastic pipe	Tube plastique	Kunststoffrohr	Tube de plastico
47	021.12.051.00.00	1		Anello stringitubo	Pipe clamping ring	Anneau serre-tube	Schlauchschele	Anillo prensatubo
50	021.12.052.00.00	1		Coperchio	Cover	Couvercle	Deckel	Tapa
51	021.12.053.00.00	2		Vite con rondella	Screw with washer	Vis avec rondelle	Schraube und Unterlegscheibe	Tornillo con arandela
52	021.12.054.00.00	1		Anello OR	O-Ring	Bague d'étanchéité	O-Ring	Anillo OR
54	021.12.055.00.00	1		Anello stringitubo	Pipe clamping ring	Anneau serre-tube	Schlauchschele	Anillo prensatubo
55	021.12.056.00.00	1		Valvola avviamento	Starting vale	Soupape demarrage	Startventil	Valvula de arranque
56	021.12.057.00.00	1		Anello OR	O-Ring	Bague d'étanchéité	O-Ring	Anillo OR
57	021.12.058.00.00	1		Molla	Spring	Ressort	Feder	Muelle
58	021.12.059.00.00	1		Supporto trasmissione	Transmission bracket	Support transmission	Befestigung Gaszug	Soporte transmisión
59	021.12.060.00.00	1		Gommino	Rubber buffer	Caoutchouc	Gummi	Goma
60	021.12.061.00.00	1		Guida trasmissione	Transmission slide	Guide trasmission	Bowdenzugführung	Guía tran.
61	021.12.062.00.00	1		Riscaldatore	Heater	Réchauffeur	Heizung	Calefactor
62	021.12.063.00.00	1		Terminale	Nipple	Embout	Nippel	Terminal
63	021.12.064.00.00	1		Pomello regolazione	Knob	Bouton	Drehknopf	Pomo

Tav.31

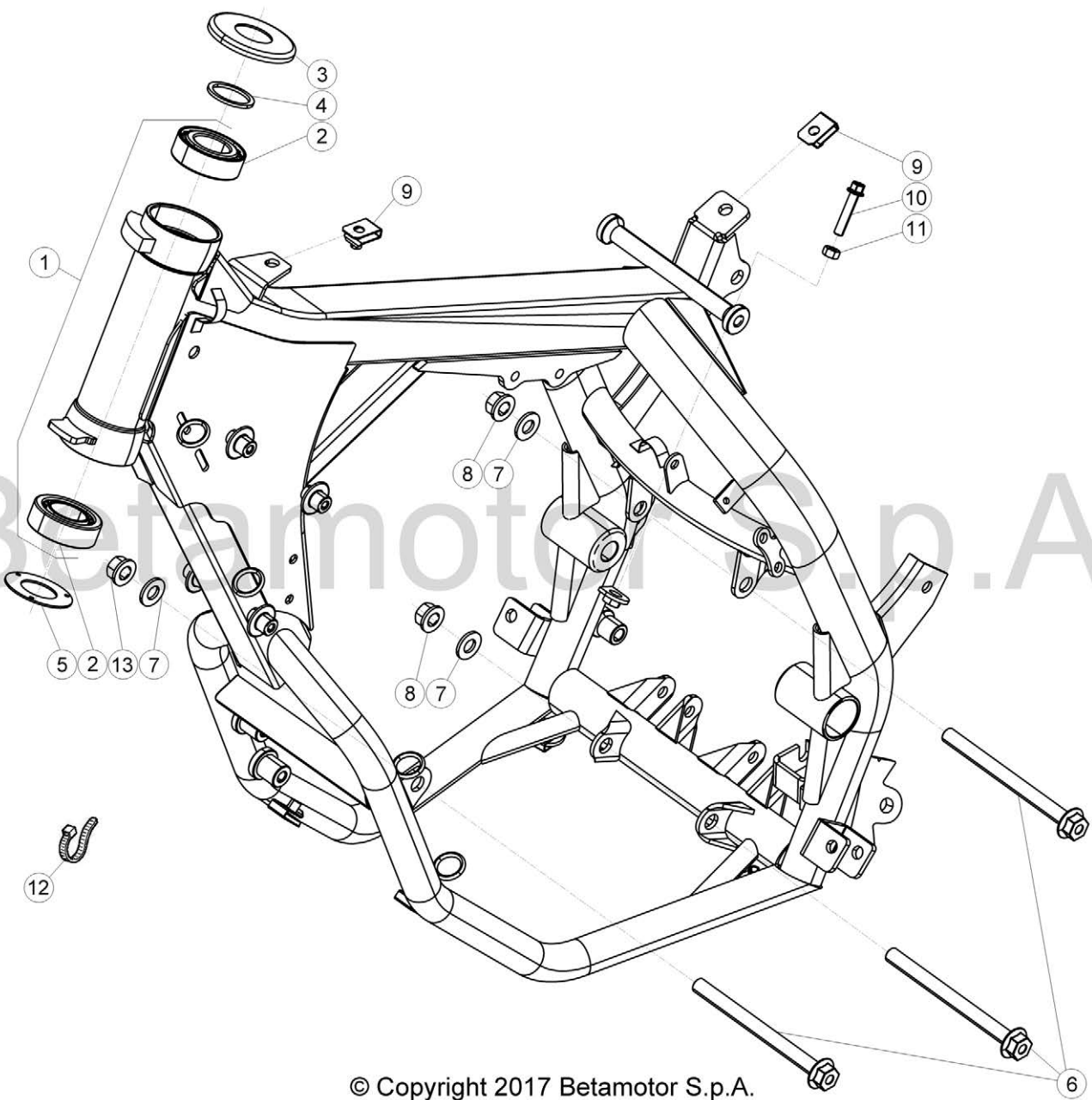

© Copyright 2017 Betamotor S.p.A.

Tav.31

Pos Loc Pos Ps Pos	Numero Number Numéro Número Nummer	Q.tà Q.ty Q.té M.ge C.ad	Nota Note Note Nota Anm.	Descrizione	Description	Désignation	Beschreibung	Descripcìon
1	021.31.027.80.50	1		Telaio completo	Frame, assy	Chassis complet	Rahmen, kpl	Bastidor compl.
2	12.99300.000	2		Cuscinetto conico 25.47.15	Conical bearing 25.47.15	Roulement conique 25.47.15	Lager 25.47.15	Cojinete conico 25.47.15
3	25.98781.000	1		Protezione cuscinetto sterzo	Ball-bearing protection	Protection roulement guidon	Abdeckung Lenkerslager	Proteccion cojinete manillar
4	27.73790.000	1		Rondella 25,7x32,2	Washer 25,7x32,2	Rondelle 25,7x32,2	U.Scheibe 25,7x32,2	Arandela 25,7x32,2
5	25.98751.000	1		Protezione cuscinetto sterzo	Ball-bearing protection	Protection roulement guidon	Abdeckung Lenkerslager	Proteccion cojinete manillar
6	31.65700.000	3		Vite TCCE M10x120 (10.9) Zinc. nera	Screw TCCE M10x120 (10.9) Zinc. black	Vis TCCE M10x120 (10.9) Zinc. noir	Schraube M10x120 (10.9) Zinc. schwarz	Tornillo M10x120 (10.9) Zinc. negro
7	27.54000.000	3		Rondella 10x21x2	Washer 10x21x2	Rondelle 10x21x2	U.Scheibe 10x21x2	Arandela 10x21x2
8	13.19010.000	2		Dado autoblocc. Basso M10	Nut M10	Ecrou M10	Mutter M10	Tuerca M10
9	25.60311.000	2		Piastrina elastica M6	Spring plate M6	Plaquelette élastique M6	Plättchen M6	Pletina elástica M6
10	11.50300.000	1		Bullone 6x30 ch rs	Bolt 6x30 ch rs	Boulon 6x30 ch rs	Bolzen 6x30 ch rs	Tornillo 6x30 ch rs
11	13.13000.000	1		Dado 6x6 ch10	Nut 6x6 ch10	Ecrou 6x6 ch10	Mutter 6x6 ch10	Tuerca 6x6 ch10
12	15.14264.000	1		Fascetta	Clamp	Collier	Schelle	Abrazadera
13	13.21010.000	1		Dado autobloccante M10	Self locking nut M10	Ecrou de sécurité M10	Mutter, selbstsichernd M10	Tuerca de seguridad M10

Tav.32

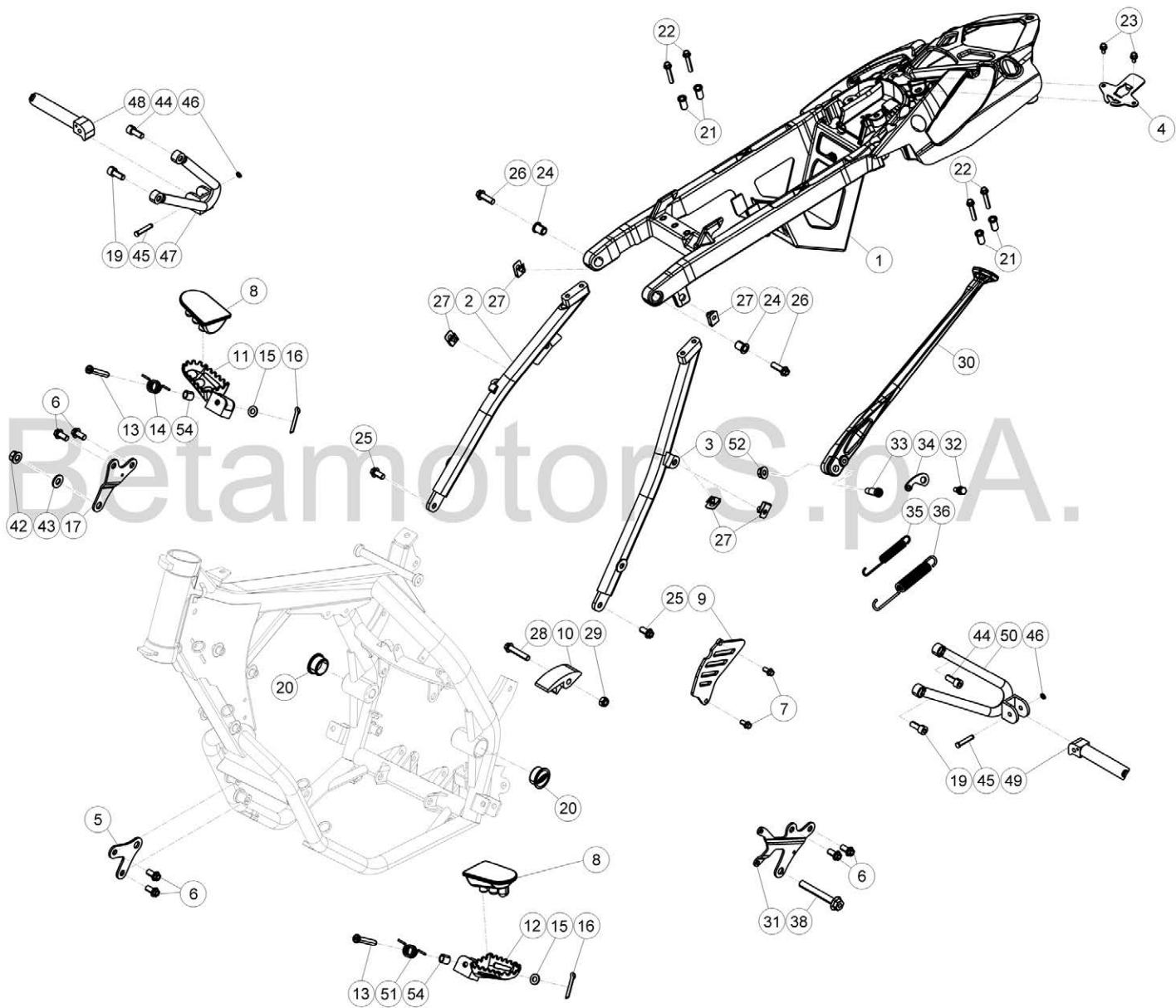

© Copyright 2017 Betamotor S.p.A.

Tav.32

Pos Loc Pos Ps Pos	Numero Number Numéro Número Nummer	Q.tà Q.ty Q.té M.ge C.ad	Nota Note Note Nota Anm.	Descrizione	Description	Désignation	Beschreibung	Descripcìon
1	021.32.102.80.59	1		Telaioetto posteriore	Rear frame	Châssis arrière	Hinterer kleiner Rahmen	Bastidor trasero
2	021.32.000.00.26	1		Braccetto destro	Right arm	Bras droit	Rechter Schutzblecharm	Brazo derecho
3	021.32.008.40.26	1		Attacco telaio posteriore	Rear frame connection	Fixation châssis arrière	Befestigung hinterer Rahmen	Sujecion bastidor trasero
4	021.32.010.00.05	1		Piastra Serratura	Lock plate	Plaque serrure	Schloßplatte	Chapa cerradura
5	021.32.042.00.05	1		Attacco motore	Engine attachment	Accouplement moteur	Motorhalterung	Acoplamiento motor
6	11.54521.000	6		Bullone M8x16	Bolt M8x16	Boulon M8x16	Bolzen M8x16	Tornillo M8x16
7	11.47015.000	2		Bullone M6x12	Bolt M6x12	Boulon M6x12	Bolzen M6x12	Tornillo M6x12
8	16.23202.000	2		Gomma pedane	Rubber buffer	Caoutchouc	Gummi	Goma
9	021.43.062.00.04	1		Coperchio pignone	Sprocket cover	Couvercle pignon	Deckel Ritzel	Tapa piñón
10	25.25601.000	1		Pattino catena	Chain shoe	Doigt chaîne	Gleitauflage	Patin cadena
11	25.32520.000	1		Pedana poggiapiedi dx	RH footrest	Repose-pieds droit	Fußraste re.	Estribera dhc
12	25.32530.000	1		Pedana poggiapiedi sx	LH footrest	Repose-pieds gauche	Fußraste li.	Estribera izq.
13	25.54466.000	2		Perno	Pin	Pivot	Zapfen	Perno
14	22.62010.000	1		Molla pedana dx	R.H. footrest spring	Ressort repose-pied droit	Rasten/Feder re.	Muelle derch. Estribera
15	27.49500.000	2		Rondella 8x18	Washer 8x18	Rondelle 8x18	U.Scheibe 8x18	Arandela 8x18
16	12.81995.000	2		Copiglia 2x15	Split pin 2x15	Goupille 2x15	Splint 2x15	Grupilla 2x15
17	021.32.004.50.00	1		Staffa fiss. testa dx.	R.H. cylinder head sec. Bracket	Bride fix. Culasse D.	Kopfbefestigungshalterung R.	Brida fij. culata der.
19	31.63900.000	2		Vite a brugola 8x25 Z.B.	Allen screw 8x25 Z.B.	Vis à 6 pans 8x25 Z.B.	Sechskantschraube 8x25 Z.B.	Tornillo a llave allen 8x25 Z.B.
20	12.55901.000	2		Tappo forcellone	Big fork plug	Bouchon fourche	Radschwinge verschluß	Tapón horquilla
21	020.32.004.00.00	4		Boccola superiore	Upper bush	Douille supérieure	Obere Buchse	Casquillo superior
22	11.50355.000	4		Bullone 6x35 ch8 rs	Bolt 6x35 ch8 rs	Boulon 6x35 ch8 rs	Bolzen 6x35 ch8 rs	Tornillo 6x35 ch8 rs
23	11.46251.000	2		Bullone flangiato M5x12	Head Flanged bolt M5x12	Boulon Bridé M5x12	Bundbolzen M5x12	Bulón con Brida M5x12
24	020.32.003.00.00	2		Boccola anteriore	Front bush	Douille avant	Vordere Buchse	Casquillo delantero
25	11.54521.000	2		Bullone M8x16	Bolt M8x16	Boulon M8x16	Bolzen M8x16	Tornillo M8x16
26	11.55440.000	2		Bullone 8x30 ch10 rs	Bolt 8x30 ch10 rs	Boulon 8x30 ch10 rs	Bolzen 8x30 ch10 rs	Tornillo 8x30 ch10 rs
27	25.60311.000	5		Piastrina elastica M6	Spring plate M6	Plaquette élastique M6	Plättchen M6	Pletina elástica M6
28	11.55480.000	1		Vite M8x40	Screw M8x40	Vis M8x40	Schraube M8x40	Tornillo M8x40
29	13.17120.000	1		Dado M8 flangiato	Nut M8	Ecrou M8	Mutter M8	Tuerca M8
30	021.32.055.00.59	1	ENDURO	Cavalletto	Central stand	Béquille	Kippständer	Caballete
30	021.32.056.00.59	1	MOTARD	Cavalletto	Central stand	Béquille	Kippständer	Caballete
31	021.32.006.50.00	1		Staffa	Bracket	Bride	Halterung	Brida
32	11.66615.000	1		Bullone spec. piastra cavalletto	Central stand special bolt	Boulon spec. plaque béq.	Spezialschraube Kippständerplatte	Tornillo especial chapa caballete
33	11.66614.000			Bullone spec. cavalletto	Special bolt	Boulon spec.	Spezialschraube	Tornillo especial
34	021.32.057.00.05	1		Piastrina aggancio molla	Bracket spring	Plaquette accroch. ressort	Plättchen federanlenkung	Placa eng. muelle
35	22.48818.000	1		Molla interna	Spring	Ressort	Feder	Muelle
36	22.48819.000	1		Molla esterna	Spring	Ressort	Feder	Muelle
38	11.63710.000	1		Bullone M10x70	Bolt M10x70	Boulon M10x70	Bolzen M10x70	Tornillo M10x70
42	13.19010.000	1		Dado autoblocc. Basso M10	Nut M10	Ecrou M10	Mutter M10	Tuerca M10
43	27.54000.000	1		Rondella 10x21x2	Washer 10x21x2	Rondelle 10x21x2	U.Scheibe 10x21x2	Arandela 10x21x2
44	31.63880.000	2		Vite 8x16 TCCE	Screw 8x16 TCCE	Vis 8x16 TCCE	Schraube 8x16 TCCE	Tornillo 8x16 TCCE
45	25.54460.000	2		Perno pedana	Footrest pin	Pivot repose-pied	Rasten Pin	Eje estribera
46	28.22550.000	2		Seeger RA4	Circlip RA4	Circlip RA4	Seeger RA4	Seeger RA4
47	017.32.040.00.26	1		Staffa supporto pedana Dx.	Right foot peg support bracket	Bride support repose-pied D.	Fußrastebefestigung rechts	Brida soporte estribera der.
48	25.32502.000	1		Pedana poggiapiedi dx	RH footrest	Repose-pieds droit	Fußraste re.	Estribera dhc
49	25.32512.000	1		Pedana poggiapiedi sx	LH footrest	Repose-pieds gauche	Fußraste li.	Estribera izq.
50	021.32.051.00.26	1		Staffa supporto pedana Sx.	Left foot peg support bracket	Bride support repose-pied G.	Fußrastebefestigung links	Brida soporte estribera izq.
51	22.62020.000	1		Molla pedana sx	L.H. footrest spring	Ressort repose-pied gauche	Rasten/Feder li.	Muelle izqui. Estribera
52	13.16000.000	1		Dado M8x6	Nut M8x6	Ecrou M8x6	Mutter M8x6	Tuerca M8x6
54	13.46530.000	2		Distanziale 8x12x17	Spacer 8x12x17	Entretoise 8x12x17	Distanz 8x12x17	Distanciadador 8x12x17

Tav.33

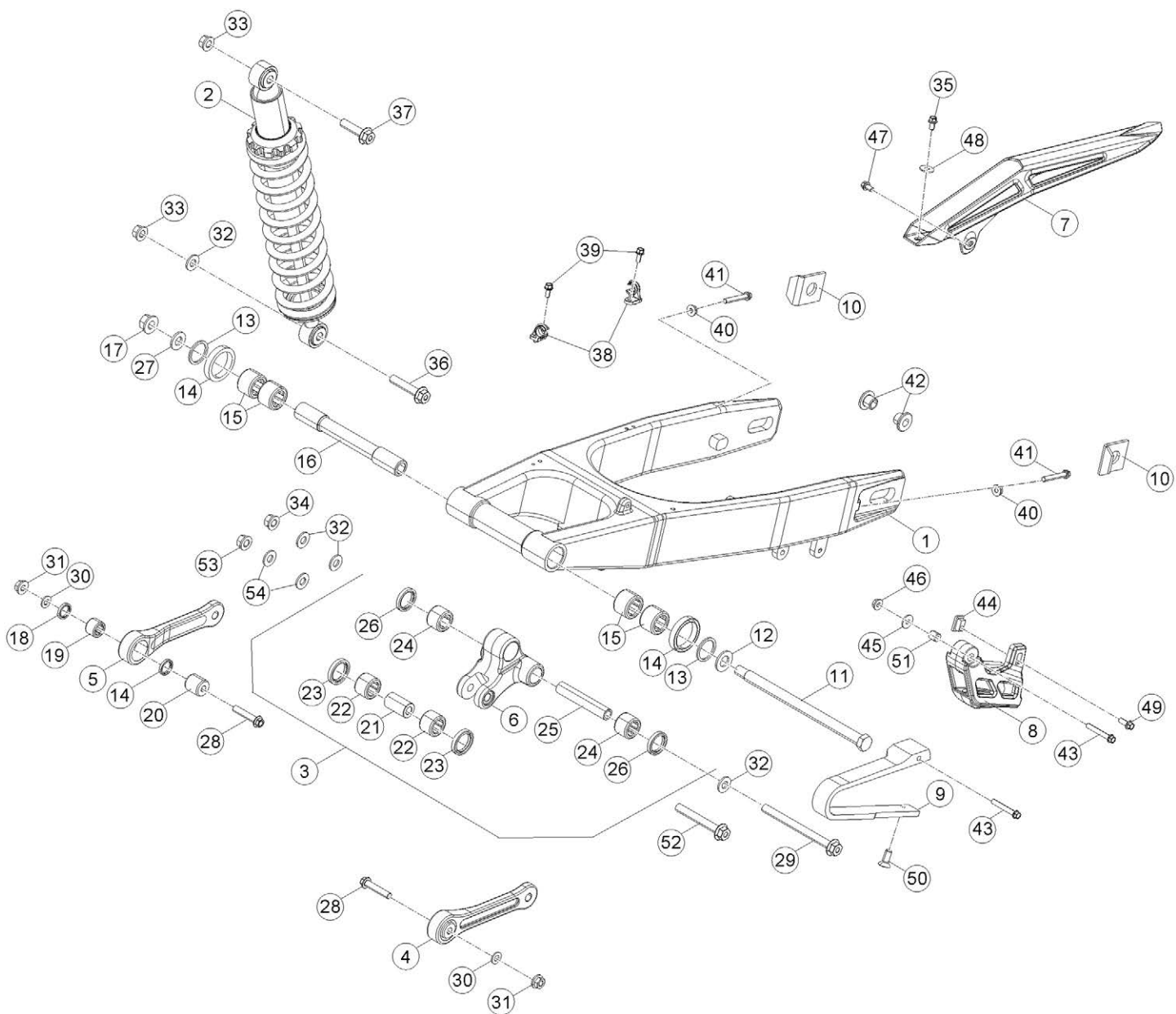

Tav.33

Pos Loc Pos Ps Pos	Numero Number Numéro Número Nummer	Q.tà Q.ty Q.té M.ge C.ad	Nota Note Note Nota Anm.	Descrizione	Description	Désignation	Beschreibung	Descripcìon
1	021.33.010.00.00	1		Forcellone	Big fork	Fourche	Radschwinge	Horquilla
2	021.33.003.80.00	1		Ammortizzatore	Damper	Amortisseur	Stoßdämpfer	Amortiguador
3	11.20476.800	1		Bilanciere completo	Lever, assy.	Balancier complet	Kipphebel kpl.	Balancin compl.
4	11.19851.866	2		Bielletta completa	Connecting rod, assy.	Biellette complète	Bolzensange komplett	Bielela completa
5	11.19851.066	2		Bielletta	Connecting rod	Biellette	Bolzensange	Bielela
6	11.20476.000	1		Bilanciere	Lever	Balancier	Kipphebel	Balancin
7	12.88591.159	1		Copricatena superiore	Up. Chain cover	Couvre-chaîne supérieur	Kettenschutz oben	Cubrecadena superior
8	29.10071.000	1		Tassello guidacatena infer.	Lower sliding block	Cheville guide de chaîne inf.	Schwingschleifklotz unten	Protector cadena inferior
9	021.33.020.10.52	1		Tassello guidacatena super.	Upper sliding block	Cheville guide de chaîne sup.	Schwingschleifklotz oben	Protector cadena superior
10	29.06201.057	2		Tendicatena	Chain tightener	Tend. de ch.	Kettenspanner	Tens. de cad.
11	25.47650.000	1		Perno forcellone	Swingarm pivot	Axe fourche AR.	Schwingbolzen	Eje basculante
12	27.61570.000	1		Rondella inox	Washer Inox	Rondelle Inox	U.Scheibe Inox	Arandela Inox
13	27.73680.000	2		Rondella in nylon 22x35x2	Rondelle en nylon 22x35x2	Nylon washer 22x35x2	Nylon-U.Scheibe 22x35x2	Arandela de nylon 22x35x2
14	10.41197.000	2		Anello parapolvere 22x28x4	Dust cover 22x28x4	Disque pare-poussière 22x28x4	Staubdeckel 22x28x4	Disco gurdapolvo 22x28x4
15	11.22980.000	4		Boccola a rullini 22x28x16	Roller cage 22x28x16	Cage Aiguille 22x28x16	Rollenkäfig 22x28x16	Jaula rodillos 22x28x16
16	021.33.016.00.00	1		Distanziale forcellone	Big fork spacer	Entretoise fourche	Distanzstück Radschwinge	Distanciadador horquilla
17	13.21130.000	1		Dado autobloccante M12	Self locking nut M12	Ecrou de sécurité M12	Mutter, selbstsichernd M12	Tuerca de seguridad M12
18	007.33.010.00.00	4		Anello parapolvere 22x28x4	Dust cover 22x28x4	Disque pare-poussière 22x28x4	Staubdeckel 22x28x4	Disco gurdapolvo 22x28x4
19	11.22056.000	2		Boccola a rullini 22x28x12	Roller cage 22x28x12	Cage Aiguille 22x28x12	Rollenkäfig 22x28x12	Jaula rodillos 22x28x12
20	032.33.093.00.00	2		Distanziale 8x22x22,9	Spacer 8x22x22,9	Entretoise 8x22x22,9	Distanzstück 8x22x22,9	Distanciadador 8x22x22,9
21	13.47610.000	1		Distanziale 10x20x34	Spacer 10x20x34	Entretoise 10x20x34	Distanzstück 10x20x34	Distanciadador 10x20x34
22	11.22850.000	2		Boccola a rullini 20x26x12	Roller cage 20x26x12	Cage Aiguille 20x26x12	Rollenkäfig 20x26x12	Jaula rodillos 20x26x12
23	10.41195.000	2		Anello parapolvere 20x26x4	Dust cover 20x26x4	Disque pare-poussière 20x26x4	Staubdeckel 20x26x4	Disco gurdapolvo 20x26x4
24	11.22450.000	2		Boccola a rullini 15x21x16	Roller cage 15x21x16	Cage Aiguille 15x21x16	Rollenkäfig 15x21x16	Jaula rodillos 15x21x16
25	13.47710.000	1		Distanziale 10x15x84	Spacer 10x15x84	Entretoise 10x15x84	Distanzstück 10x15x84	Distanciadador 10x15x84
26	10.41190.000	2		Anello parapolvere 15x21x3	Dust cover 15x21x3	Disque pare-poussière 15x21x3	Staubdeckel 15x21x3	Disco gurdapolvo 15x21x3
27	27.55600.000	1		Rondella 12x24	Washer 12x24	Rondelle 12x24	Scheibe 12x24	Arandela 12x24
28	11.55500.000	2		Bullone M8x40	Bolt M8x40	Boulon M8x40	Bolzen M8x40	Tornillo M8x40
29	31.65700.000	1		Vite TCCE M10x120 (10.9)	Screw TCCE M10x120 (10.9)	Vis TCCE M10x120 (10.9)	Schraube M10x120 (10.9)	Tornillo M10x120 (10.9)
				Zinc. nera	Zinc. balck	Zinc. noir	Zinc. schwarz	Zinc. negro
30	27.49500.000	2		Rondella 8x18	Washer 8x18	Rondelle 8x18	U.Scheibe 8x18	Arandela 8x18
31	13.17020.000	2		Dado autoblocc. Basso M8	Nut M8	Ecrou M8	Mutter M8	Tuerca M8
32	27.54000.000	4		Rondella 10x21x2	Washer 10x21x2	Rondelle 10x21x2	U.Scheibe 10x21x2	Arandela 10x21x2
33	13.21050.000	1		Dado flangiato M10X1,25	Flanged nut M10X1,25	Ecrou bordé M10X1,25	Flanschmutter M10X1,25	Tuerca embreada M10X1,25
34	13.19010.000	1		Dado autoblocc. Basso M10	Nut M10	Ecrou M10	Mutter M10	Tuerca M10
35	31.30490.051	1		Vite M6x8 TTLIC testa 12	Screw M6x8 TTLIC	Vis M6x8 TTLIC	Schraube M6x8 TTLIC	Tornillo M6x8 TTLIC
36	11.63000.000	1		Bullone M10x50	Bolt M10x50	Boulon M10x50	Bolzen M10x50	Tornillo M10x50
37	11.62050.000	1		Bullone fiss. ammortizzatore M10x45	Damper sec. bolt M10x45	Boulon fix. amortisseur M10x45	Befestigungsbolzen M10x45	Tornillo fij amortiguador M10x45
38	15.14605.000	2		Passatubo	Grommet	Passe-tube	Rohrdurchgang	Pasa-tubo
39	11.46251.000	2		Bullone flangiato M5x12	Head Flanged bolt M5x12	Boulon Bridé M5x12	Bundbolzen M5x12	Bulón con Brida M5x12
40	13.15000.000	2		Dado M7	Nut M7	Ecrou M7	Mutter M7	Tuerca M7
41	11.50760.000	2		Bullone M7x40	Bolt M7x40	Boulon M7x40	Bolzen M7x40	Tornillo M7x40
42	11.27280.000	2		Boccola	Bush	Moyeu	Büchse	Buje
43	11.50360.000	1		Bullone M6x40	Bolt M6x40	Boulon M6x40	Bolzen M6x40	Tornillo M6x40
44	13.48868.000	1		Distanziale tassello guidacatena	Sliding block spacer	Entretoise cheville guide de chaîne	Abstandstück Schwingschleifklotz	Separador protector cadena/basculante
45	27.42000.000	1		Rondella 6x18	Washer 6x18	Rondelle 6x18	U.Scheibe 6x18	Arandela 6x18
46	13.13020.000	1		Dado autobloccante M6	Self locking nut M6	Ecrou de sécurité M6	Mutter, selbstsichernd M6	Tuerca de seguridad M6
47	31.30490.051	1		Vite M6x8 TTLIC testa 12	Screw M6x8 TTLIC	Vis M6x8 TTLIC	Schraube M6x8 TTLIC	Tornillo M6x8 TTLIC
48	27.42000.000	1		Rondella 6x18	Washer 6x18	Rondelle 6x18	U.Scheibe 6x18	Arandela 6x18
49	11.48025.000	1		Bullone 6x16 ch 8 rs	Bolt 6x16 ch 8 rs	Boulon 6x16 ch 8 rs	Bolzen 6x16 ch 8 rs	Tornillo 6x16 ch 8 rs
50	31.30600.000	1		Vite TSPCE M6x16	Screw M6x16	Vis M6x16	Schraube M6x16	Tornillo M6x16
51	13.49191.000	1		Distanziale	Spacer	Entretoise	Distanzstück	Distanciadador
52	31.65620.000	1		Vite TCCE 10x80	Screw TCCE 10x80	Vis TCCE 10x80	Schraube TCCE 10x80	Tornillo TCCE 10x80
53	13.21040.000	1		Dado autobloccante M10	Self locking nut M10	Ecrou de sécurité M10	Mutter, selbstsichernd M10	Tuerca de seguridad M10
54	27.54250.000	2		Rondella 10x25x3	Washer 10x25x3	Rondelle 10x25x3	U.Scheibe 10x25x3	Arandela 10x25x3

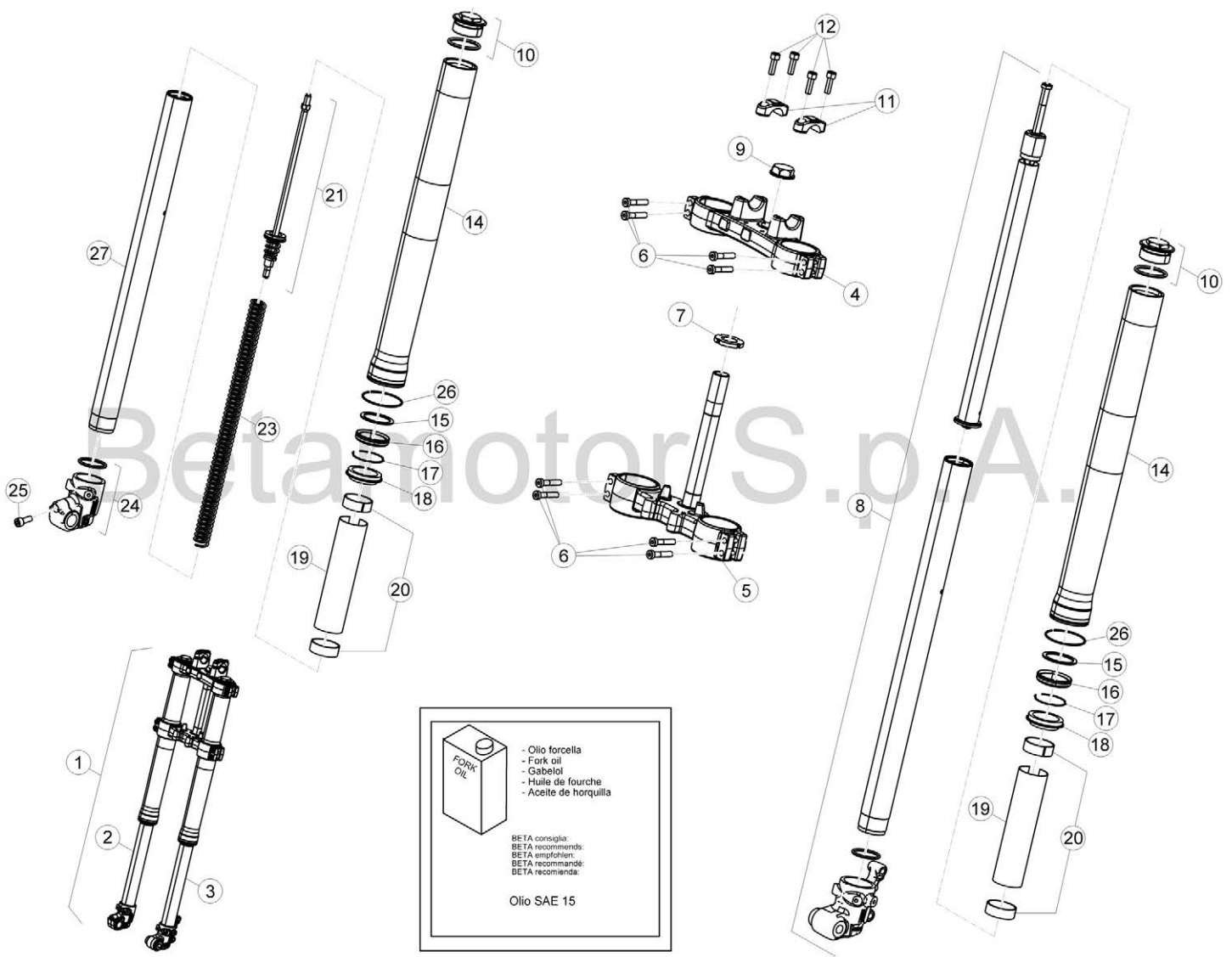

© Copyright 2016 Betamotor S.p.A.



Tav.34

Pos Loc Pos Ps Pos	Numero Number Numéro Número Nummer	Q.tà Q.ty Q.té M.ge C.ad	Nota Note Note Nota Anm.	Descrizione	Description	Désignation	Beschreibung	Descripcìon
1	021.34.002.80.00	1		Forcella completa	Stirrup assy.	Fourchette compl.	Schaltgabel, Kompl.	Horquilla compl.
2	021.34.026.80.00	1		Gamba Dx. compl.	R.H. fork leg assy	Fourche complete D.	Telegabel Kpl. R.	Horquilla derech. compl.
3	021.34.027.80.00	1		Gamba Sx. compl.	L.H. fork leg assy	Fourche compl. G.	Telegabel, Kpl. L.	Horquill izrda. compl.
4	024.34.063.00.59	1		Piastra superiore	Upper plate	Plaque supérieure	Platte oben	Chapa superior
5	024.34.018.80.59	1		Piastra inf. con perno	Lower plate with pin	Plaque inférieure avec pivot	Platte unter mit Bolzen	Chapa inferior con perno
6	11.55510.000	8		Vite TTCE M8x40 RS CH10	Screw TTCE M8x40 RS CH10	Vis TTCE M8x40 RS CH10	Schraube TTCE M8x40 RS CH10	Tornillo TTCE M8x40 RS CH10
7	024.34.033.00.00	1		Ghiera registro cuscinetti di sterzo	Steering bearings adjusting ring nut	Collier de réglage roulement guidon	Einstellzwinge Lenkungslager	Virola aiuste cojinetes de la guida
8	021.34.024.80.00	1		Cartuccia idraulica completa	Hydraulic fork spares	Cartouche hydraulique compl.	Hydraulischer Gabeldaempfer	Cartucho hidraulico completa
9	024.34.040.00.00	1		Dado	Nut	Ecrou	Mutter	Tuerca
10	024.34.663.80.00	2		Tappo completo	Complete cap	Bouchon complet	Verchluß komplett	Tapón completo
11	024.34.064.00.59	2		Cavalotto	U bolt	Etrier	Brücke	Brida
12	31.63900.000	4		Vite M8X25 TCCE	Screw M8X25 TCCE	Vis M8X25 TCCE	Schraube M8X25 TCCE	Tornillo M8X25 TCCE
14	024.34.666.00.04	2		Fodero	Sleeve	Protection	Schutzstück	Protección
15	024.34.667.00.00	2		Rondella d.52,8x43x2	Washer d.52,8x43x2	Rondelle d.52,8x43x2	U.Scheibe d.52,8x43x2	Arandela d.52,8x43x2
16	024.34.668.00.00	2		Anello di tenuta d40,9x53	Oil seal d40,9x53	Joint spie d40,9x53	Dichtring d40,9x53	Retén de aceite d40,9x53
17	024.34.669.00.00	2		Anello d'arresto ø1,8	Check ring ø1,8	Bague d'arrêt ø1,8	Sicherungsring ø1,8	Anillo de bloqueo ø1,8
18	024.34.670.00.00	2		Parapolvere d40,9x53,4	Dust cover d40,9x53,4	Pare-pouss. d40,9x53,4	Staubdeckel d40,9x53,4	Guardapolvo d40,9x53,4
19	024.34.671.00.00	2		Distanziale d45x179,7 tall 16	Spacer d45x179,7 tall 16	Entretoise d45x179,7 tall 16	Distanzstück d45x179,7 tall 16	Distanciador d45x179,7 tall 16
20	024.34.672.82.00	2		Coppia boccole d41x45x15	Bush couple d41x45x15	Couple douilles d41x45x15	Buchsenpaar d41x45x15	Par casquillos d41x45x15
21	024.34.673.80.00	1		Cartuccia meccanica forcella	Kit mechanic spares fork	Cartouche mecanique fourche	Gabeldaempfer	Cartucho mecanica horquilla
23	021.34.025.00.00	1		Molla forcella	Fork spring	Ressort fourche	Gabelfeder	Muelle horquilla
24	024.34.676.80.00	1		Piedino dx forcella	R.H. fork foot	Pied de fourche droit	Gabelfuß rechts	Pata horquilla der.
25	31.63890.000	1		Vite a brugola 8x20 TCCE	Allen screw 8x20 TCCE	Vis à 6 pans 8x20 TCCE	Sechskantschraube 8x20 TCCE	Tornillo a llave allen 8x20 TCCE
26	024.34.664.00.00	2		Anello d'arresto ø2	Check ring ø2	Bague d'arrêt ø2	Sicherungsring ø2	Anillo de bloqueo ø2
27	024.34.683.00.00	1		Tubo dx completo forcella	RH compl. Fork tube	Tube compl. Droit fourche	Gabelstandrohr rechts	Tubo derecho compl. Horquilla

Tav.35

Pos Loc Ps Pos	Numero Number Numéro Número Nummer	Q.tà Q.ty Q.té M.ge C.ad	Nota Note Note Nota Anm.	Descrizione	Description	Désignation	Beschreibung	Descrìcion
1	014.35.050.00.59	1	ENDURO	Manubrio	Handlebars	Guidon	Lenker	Manillar
1	22.20393.059	1	MOTARD	Manubrio	Handlebars	Guidon	Lenker	Manillar
2	036.35.005.00.00	1		Coppia manopole	Grips (couple)	Poignées (couple)	Handgriffpaar	Manecilla (juego)
3	28.92927.000	1		Specchio retrovisore dx	RH rear view mirror	Retroviseur droit	Rückspiegel re.	Espejo retrovisor derecho
4	28.92925.000	1		Specchio retrovisore sx	LH rear view mirror	Retroviseur gauche	Rückspiegel li.	Espejo retrovisor izquierdo
5	020.35.011.80.00	1		Comando gas con manopole	Throttle control with grips	Comm. gaz avec poignées	Gasdrehgriff mit Handgriff	Mando gas con manecillas
6	13.06515.000	1		Dispositivo dx	Right device	Dispositif droit	Vorrichtung re.	Dispositivo derecho
7	13.36696.000	1		Dip luci	Switch	Commodo feux	Lichtschalter	Mando luces
8	021.35.001.00.00	1		Trasmissione gas	Throttle transmiss.	Transmission gaz	Gaszug	Transmisión gas
9	21.02067.009	1		Leva comando freno	Brake lever	Levier du frein	Bremshebel	Palanca freno
10	21.02396.000	1		Leva com. frizione	Clutch lever	Levier complet embrayage	Kupplungsarmatur	Bomba embrague
11	29.10281.000	1		Oblò ispezione livello olio	Oil level sight glass	Hublot d'inspection niveau huile	Ölkontrollschauglas	Visor de inspección nivel aceite
12	28.22550.000	1		Seeger RA4	Circlip RA4	Circlip RA4	Seeger RA4	Seeger RA4
13	25.41873.000	1		Puntalino	Push piece	Piece de pression	Druckstück	Varilla de presión
14	25.41874.000	1		Puntalino	Push piece	Piece de pression	Druckstück	Varilla de presión
15	024.36.014.00.00	1		Vite	Screw	Vis	Schraube	Tornillo
16	31.96810.000	2		Vite TSPIC 4X12	Screw TSPIC 4X12	Vis TSPIC 4X12	Schraube TSPIC 4X12	Tornillo TSPIC 4X12
17	12.55916.000	1		Coperchio pompa freno	Pump cover	Couvercle pompe	Deckel	Tapa bomba
18	13.11510.000	1		Dado 6x4 ch10	Nut 6x4	Ecrou 6x4 ch10	Mutter 6x4	Tuerca 6x4 llave 10
19	12.30103.000	1		Cappellotto fissaggio pompa	Holder	Capuchon levier frein	Druckplatte f.	Pumpe Tapa fijación bomba
20	21.27107.000	1		Leva freno anter.nuda	Front brake lever only	Levier frein avant nue	Bremshebel	Maneta freno
21	31.96808.000	4		Vite	Screw	Vis	Schraube	Tornillo
22	20.05064.000	1		Kit pistoncino pompa ant.	Piston kit front master cyl.	Kit piston. maître cyl. AV.	Kolbensatz vorderhauptbremszylinder	Kit pistón bomba del.
23	20.08274.000	1		Kit revisione pompa	Kit for master cyl. overhauling	Kit rév. maître cyl.	Reparatursatz Hauptbremszylinder	Kit revisión bomba
24	21.27086.000	1		Leva com.friz.nuda	Clutch lever only	Levier complet embrayage nue	Kupplungshebel	Palanca embrague
25	21.70147.000	1		Leva comando starter	Starter unit lever	Levier starter	Starterhebel	Palanca estrang. aire
26	021.35.005.00.00	1		Trasmissione frizione	Clutch transmission	Transmission embrayage	Kupplungsseil	Transmisión embrague
27	12.55005.000	1		Collarino fissaggio leva	Fixing rest clutch lever	Petit collier fixation levier	Befestigung f. Bremshebel	Guarnición fijación palanca
28	31.80110.000	1		Vite fiss. leva	Fixing lever screw	Vis fix. levier	Schraube hebel	Tornillo fij. palanca
29	021.35.004.00.00	1		Trasmissione starter	Choke transmiss.	Transmission starter	Starterseil	Transmisión estrang.
30	16.50510.000	2		Guarnizione 10x15x1 in rame	Gasket 10x15x1 copper	Joint 10x15x1 cuivre	Dichtung 10x15x1 Kupfer	Junta 10.15.1 (cobre)
31	021.36.014.00.00	1		Tubo Freno	Brake tube	Tuyau du frein	Bremsleitung	Tubo freno
32	11.65053.000	1		Bullone forato 10x1,25	Pierced bolt 10x1,25	Boulon avec trou 10x1,25	Bolzen 10x1,25	Tornillo 10x1,25
33	15.14264.000	1		Fascetta	Clamp	Collier	Schelle	Abrazadera
35	25.24442.000	1		Passacavo 6/8	Fair lead 6/8	Passe-fils 6/8	Kabelführung 6/8	Pasa-cable 6/8
36	25.24443.000	2		Passacavo 6/6	Fair lead 6/6	Passe-fils 6/6	Kabelführung 6/6	Pasa-cable 6/6
37	25.24446.000	2		Passacavo 6/4	Fair lead 6/4	Passe-fils 6/4	Kabelführung 6/4	Pasa-cable 6/4
38	18.87010.000	1		Interruttore stop	Stop switch	Interrupteur stop	Stopschalter	Interruptor stop



- Olio freni
- Brake fluid
- Bremsflüssigkeit
- Liquide de frein
- El líquido de frenos

BETA consiglia:
 BETA recommends:
 BETA empfohlen:
 BETA recommandé:
 BETA recomienda:

BRAKE FLUID DOT 4
BRAKE FLUID DOT 5.1

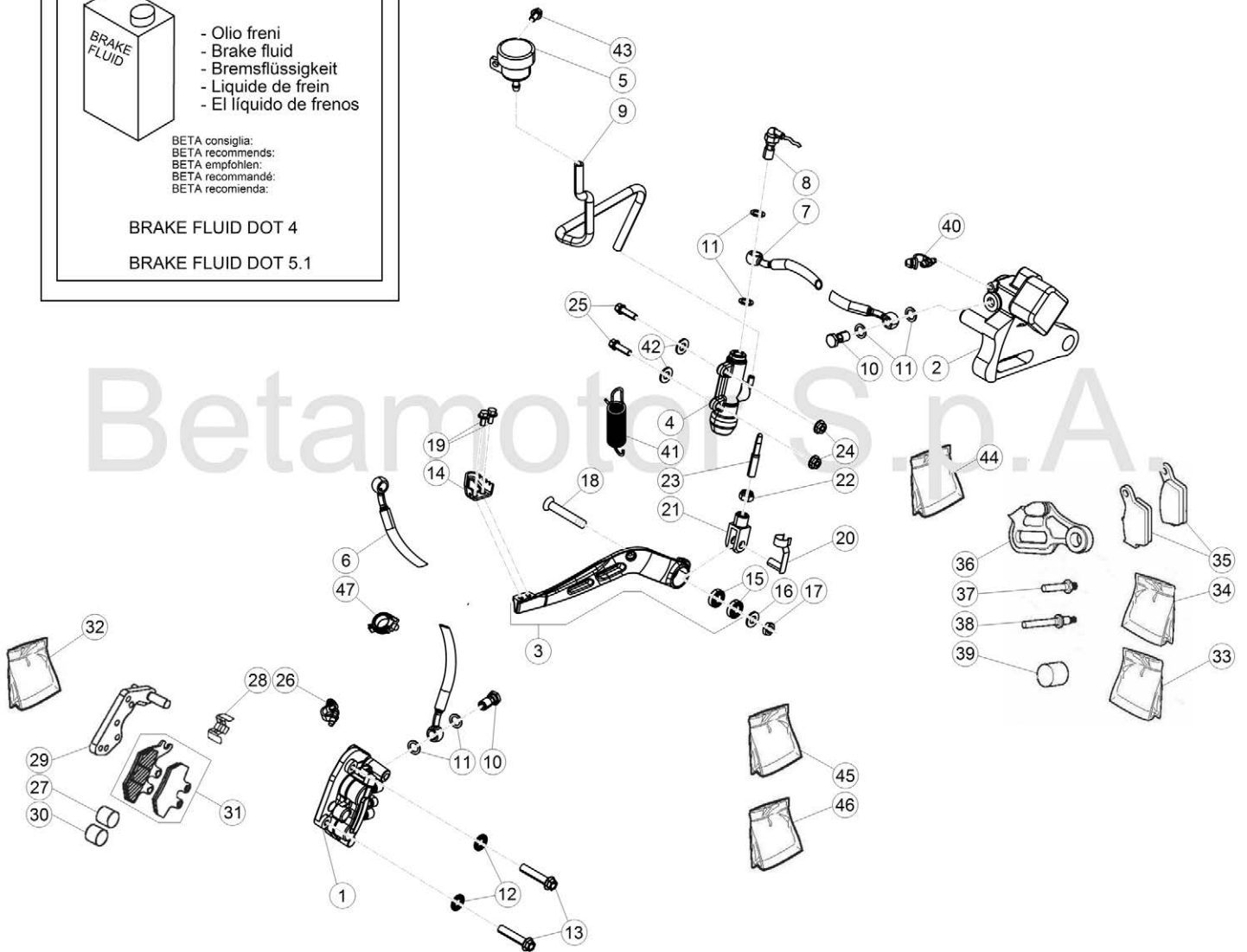

© Copyright 2018 Betamotor S.p.A.

Tav.36

Pos Loc Pos Ps Pos	Numero Number Numéro Número Nummer	Q.tà Q.ty Q.té M.ge C.ad	Nota Note Note Nota Anm.	Descrizione	Description	Désignation	Beschreibung	Descripcìon
1	021.36.005.80.00	1		Pinza freno anteriore	Front disk brake caliper	Etrier de frein AV.	Bremszange-Scheibe	Pinza freno del.
2	25.03073.009	1		Pinza freno posteriore	Rear disk brake caliper	Etrier de frein AR.	Bremszange	Pinza del freno tras.
3	020.36.001.80.00	1		Pedale freno	Brake pedal	Pédale frein	Fussbremspedal	Pedal freno
4	25.91177.009	1		Pompa freno posteriore	Rear brake cylinder	Maître cylindre frein ar.	Hauptbremszylinder	Bomba freno trasero
							Hinterradbremse	
5	021.36.012.00.00	1		Serbatoio olio freni	Brake oil tank	Réservoir huile frein	Bremsflüssigkeitstank	Depósito aceite frenos
6	021.36.014.00.00	1		Tubo freno	Brake tube	Tuyau du frein	Bremsleitung	Tubo freno
7	021.36.030.00.00	1		Tubo freno posteriore	Rear brake tube	Tuyau du frein AR.	Hintere Bremsleitung	Tubo freno trasero
8	021.36.015.00.00	1		Interruttore stop	Stop switch	Interrupteur stop	Stopschalter	Interruptor stop
9	021.36.016.00.00	1		Tubo serbatoio olio	Oil reservoir pipe	Durite réservoir huile	Leitung zwischen Ölbehälter	Tubo depósito aceite
10	11.65053.000	2		Bullone forato 10x1,25	Pierced bolt 10x1,25	Boulon avec trou 10x1,25	Hohlschraube 10x1,25	Perno banjo 10x1,25
11	16.50510.000	6		Guarnizione 10x15x1 in rame	Gasket 10x15x1 copper	Joint 10x15x1 cuivre	Dichtung 10x15x1 Kupfer	Junta 10.15.1 (cobre)
12	27.56055.000	2		Rondella	Washer	Rondelle	U.Scheibe	Arandela
13	11.55470.000	2		Bullone M8x35 rs ch10	Bolt M8x35 rs ch10	Boulon M8x35 rs ch10	Bolzen M8x35 rs ch10	Tornillo M8x35 rs ch10
14	22.90053.000	1		Mozzetto pedale freno	Hub brake pedal	Moyeu pédale frein	Nabe bremspedal	Cubo pedal freno
15	12.93388.000	2		Cuscinetto 8x22x7	Bearing 8x22x7	Roulement 8x22x7	Lager 8x22x7	Cojinete 8x22x7
16	27.49500.000	1		Rondella 8x16	Washer 8x16	Rondelle 8x16	U.Scheibe 8x16	Arandela 8x16
17	13.17020.000	1		Dado autobloccante M8	Self locking nut M8	Ecrou de sécurité M8	Mutter, selbstsichernd M8	Tuerca de seguridad M8
18	31.63985.000	1		Vite TSPCE 8.50 cl 10.9	Screw TSPCE 8.50 cl 10.9	Vis TSPCE 8.50 cl 10.9	Schraube TSPCE 8.50 cl 10.9	Tornillo TSPCE 8.50 cl 10.9
19	11.46251.000	2		Bullone flangiato M5x12	Head Flanged bolt M5x12	Boulon Bridé M5x12	Bundbolzen M5x12	Bulón con Brida M5x12
20	021.36.034.00.00	1		Staffa	Bracket	Support	Halterung	Soporte
21	021.36.033.00.00	1		Forcellino pedale freno	Rear brake fork	Chape pédale frein	Bremsgabel	Horquilla pedal de freno
22	13.16000.000	1		Dado M8x6	Nut M8x6	Ecrou M8x6	Mutter M8x6	Tuerca M8x6
23	021.36.032.00.00	1		Asta pompa freno	Brake pump rod	Tige de pompe frein	Pumpenstange	Vastago de la bomba freno
24	13.13020.000	2		Dado autobloccante M6	Self locking nut M6	Ecrou de sécurité M6	Mutter, selbstsichernd M6	Tuerca de seguridad M6
25	11.49070.000	2		Bullone 6x20 ch rs	Bolt 6x20 ch rs	Boulon 6x20 ch rs	Bolzen 6x20 ch rs	Tornillo 6x20 ch rs
26	31.96801.000	1		Vite spurgo pinza	Special screw	Vis pour pince	Spezial schraube	Tornillo aliento pinza
27	021.36.047.00.00	2		Pistoncino pompa D.22	Brake pliers piston D.22	Piston etrier D.22	Kolben für Pumpe D.22	Piston bomba D.22
28	021.36.042.00.00	1		Molla pastiglie freno	Brake pads spring	Ressort plaquettes frein	Feder Bremsbeläge	Muelle pastillas de freno
29	021.36.039.00.00	1		Staffa pinza freno	Caliper bracket	Support pince	Bremszangehalterung	Soporte pinza
30	25.69444.000	1		Pistoncino pompa D.25	Brake pliers piston D.25	Piston etrier D.25	Kolben für Pumpe D.25	Piston bomba D.25
31	021.36.045.82.00	1		Pastiglie freno	Brake pads	Plaquettes pince	Bremsbeläge hinten	Pastillas pinza
32	021.36.054.82.00	1		Gruppo guarnizioni	Master cyl. packings kit	Jeu joints maître cyl.	Dichtungensatz	Grupo juntas bomba
							Hauptbremszylinder	
33	20.08272.000	1		Kit ricambi pinza	Kit (spare parts)	Jeu pieces	Reparatursatz Zange	Juego piezas pinza
34	20.08273.000	1		Kit ricambi pinza (perni grano)	Kit pivots (spare parts)	Jeu pieces (pivots)	Reparatursatz Zange (Zapfen)	Juego piezas pinza (pernos)
35	25.25345.000	1		Pastiglie per pinza	Brake pads	Plaquettes pince	Bremsbeläge hinten	Pastillas pinza
36	28.98121.000	1		Supporto pinza freno	Brake plier support	Support pince frein	Bremszange Halter	Soporte pinza freno
37	25.41854.000	1		Perno ancoraggio pinza D=8	Plier pin D=8	Pivot ancrage etrier D=8	Zangshalter D=8	Varilla esp. Pinza D=8
38	25.41856.000	1		Perno ancoraggio pinza D=9	Plier pin D=9	Pivot ancrage etrier D=9	Zangshalter D=9	Varilla esp. Pinza D=9
39	25.69459.000	1		Pistoncino pompa D.30	Brake pliers piston D.30	Piston etrier D.30	Kolben für Pumpe D.30	Piston bomba D.30
40	31.96801.000	1		Vite spurgo pinza	Special screw	Vis pour pince	Spezial schraube	Tornillo aliento pinza
41	021.36.031.00.00	1		Molla pedale freno	Brake pedal spring	Ressort Pédale Frein	Feder Fussbremspedal	Muelle pedal de freno
42	27.40500.000	2		Rondella 6x13	Washer 6x13	Rondelle 6x13	U.Scheibe 6x13	Arandela 6x13
43	11.46501.000	1		Bullone M6x10	Bolt M6x10	Boulon M6x10	Bolzen M6x10	Tornillo M6x10
44	25.69456.000	1		Pistoncino completo pompa d.12	Piston assy, pump d.12	Piston compl. pompe d.12	Kolben klpt. Pumpe d.12	Piston completo bomba d.12
45	20.02707.000	1		Kit guarnizioni pompa	Master cyl. packings kit	Jeu joints maître cyl.	Dichtungensatz	Grupo juntas bomba
							Hauptbremszylinder	
46	20.08268.000	1		Kit revisione pompa	Kit for master cyl. overhauling	Kit rév. maître cyl.	Reparatursatz	Kit revisión bomba
							Hauptbremszylinder	
47	25.24441.000	1		Passacavo a scatto	Snap-on grommet	Passe-câble à dédic	Schnapp Kabeldurchgang	Pasacables a presión

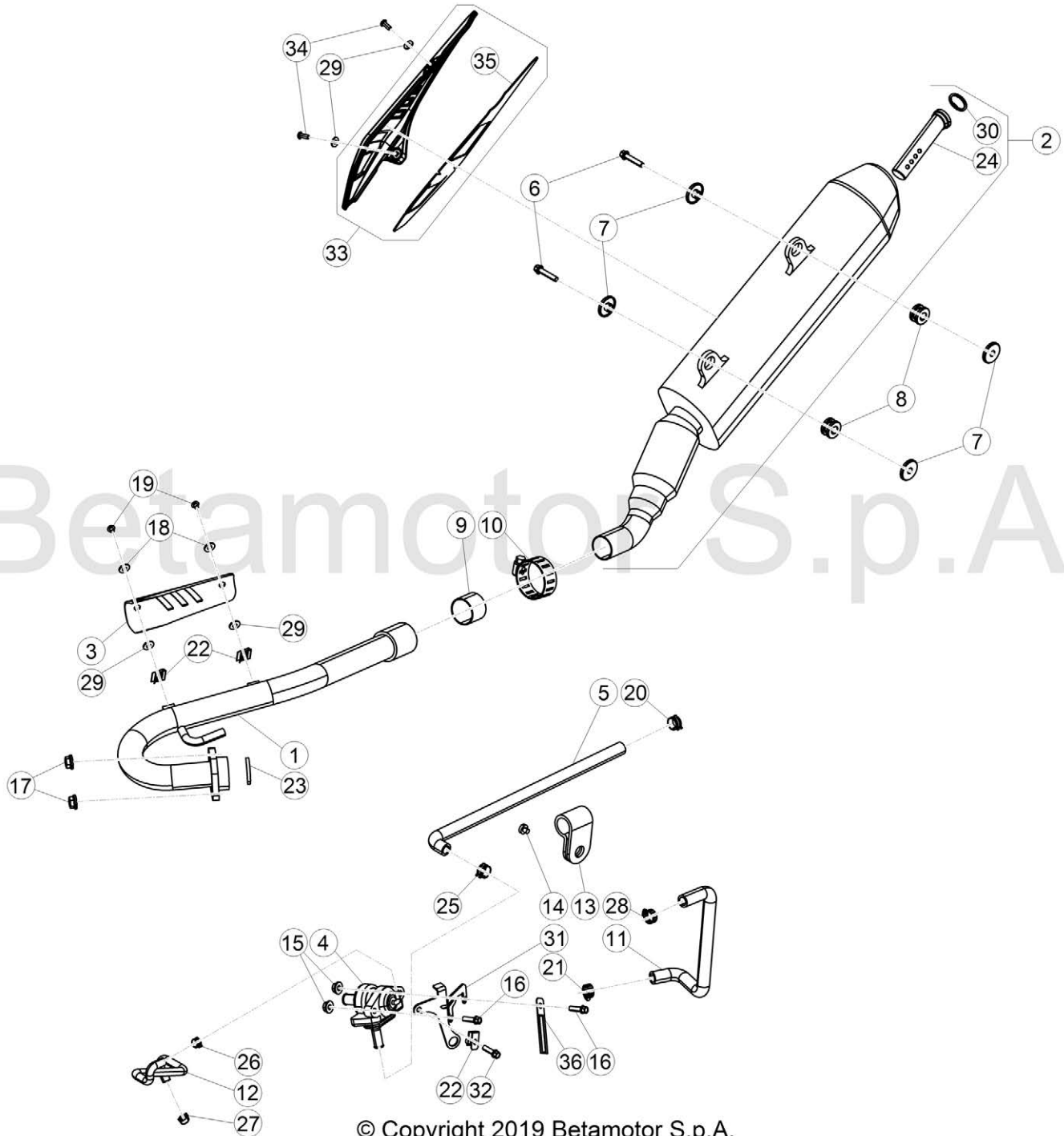

© Copyright 2019 Betamotor S.p.A.

Pos Loc Pos Ps Pos	Numero Number Numéro Número Nummer	Q.tà Q.ty Q.té M.ge C.ad	Nota Note Note Nota Anm.	Descrizione	Description	Désignation	Beschreibung	Descrìcion
1	021.37.028.80.00	1		Collettore di scarico	Exhaust manifold	Collecteur Echappement	Abgaskrümmer	Colector escape
2	021.37.033.80.00	1		Silenziatore	Silencer	Silencieux	Endschalldämpfer	Silenciador
3	25.98917.012	1		Protezione tubo scarico	Exhaust guard	Protection échappement	Auspuffschutz	Protección escape
4	021.37.031.82.00	1		Valvola AIS	AIS Valve	Soupape AIS	Ventil AIS	Válvula AIS
5	021.37.007.00.00	1		Tubo filtro-Valvola AIS	Pipe Filter box-AIS Valve	Tuyau Boîtier filtre-Soupape AIS	Leitung Sicherungskasten-Ventil AIS	Tubo caja del filtro-Válvula AIS
6	11.50300.000	2		Bullone 6x30 ch rs	Bolt 6x30 ch rs	Boulon 6x30 ch rs	Bolzen 6x30 ch rs	Tornillo 6x30 ch rs
7	13.49187.000	4		Scodellino	Stop washer	Rondelle d'ar	Federaufnahme	Platillo
8	032.37.013.00.00	2		Silent-bloc	Silentbloc	Silentbloc	Puffer	Silent-block
9	16.80813.000	1		Guarnizione	Packing	Joint	Dichtung	Junta
10	15.14255.000	1		Fascetta	Clamp	Collier	Schelle	Abrazadera
11	021.37.029.82.00	1		Tubo marmitta-Valvola AIS	Pipe Silencer-AIS Valve	Tuyau Silencieux-Soupape AIS	Leitung Auspufftopf-Ventil AIS	Tubo Silenciador-Válvula AIS
12	021.37.004.00.00	1		Tubo carburatore-Valvola AIS	Pipe Carburator-AIS Valve	Tuyau Carburateur-Soupape AIS	Leitung Vergaser-Ventil AIS	Tubo Carburador-Válvula AIS
13	25.25182.000	1		Fascetta	Clamp	Collier	Schelle	Abrazadera
14	31.23500.000	1		Vite autofilettante 4.2x13	Self tapping screw 4.2x13	Vis taraud 4.2x13	Schraube, Blech 4.2x13	Tornillo autorrosc. 4.2x13
15	13.12550.000	2		Dado flangiato M6	Flanged nut M6	Ecrou bordé M6	Flanschmutter M6	Tuerca embreadada M6
16	11.49070.000	2		Bullone 6x20 RS CH8	Bolt 6x20 RS CH8	Boulon 6x20 RS CH8	Bolzen 6x20 RS CH8	Tornillo 6x20 RS CH8
17	13.17121.000	2		Dado speciale M8	Special nut M8	Ecrou spéciale M8	Spezialmutter M8	Tuerca especial M8
18	27.39002.000	2		Rondella 6x14	Washer 6x14	Rondelle 6x14	U.Scheibe 6x14	Arandela 6x14
19	31.38020.000	2		Vite 6x10 TBCE	Screw 6x14 TBCE	Vis 6x14 TBCE	Schraube 6x14 TBCE	Tornillo 6x14 TBCE
20	10.67470.000	1		Anello stringitubo	Pipe clamping ring	Anneau serre-tube	Schlauchselle	Anillo prensatubo
21	10.67470.000	1		Anello stringitubo	Pipe clamping ring	Anneau serre-tube	Schlauchselle	Anillo prensatubo
22	25.60311.000	3		Piastrina elastica M6	Spring plate M6	Plaque élastique M6	Plättchen M6	Pletina elástica M6
23	021.37.003.00.00	1		Guarnizione	Packing	Joint	Dichtung	Junta
24	021.37.021.00.00	1		Dispositivo limitazione DB	DB reduction device	Reducteur de bruit	Dämmpaket	Reductor de ruido
25	10.67436.000	1		Anello stringitubo	Pipe clamping ring	Anneau serre-tube	Schlauchselle	Anillo prensatubo
26	10.67440.000	1		Anello stringitubo	Pipe clamping ring	Anneau serre-tube	Schlauchselle	Anillo prensatubo
27	10.67370.000	1		Anello stringitubo	Pipe clamping ring	Anneau serre-tube	Schlauchselle	Anillo prensatubo
28	15.15320.000	1		Anello stringitubo	Pipe clamping ring	Anneau serre-tube	Schlauchselle	Anillo prensatubo
29	16.47491.000	4		Guarnizione speciale 6X13 SP 1,8	Special packing 6X13 SP 1,8	Joint spéciale 6X13 SP 1,8	Spezialdichtung 6X13 SP 1,8	Junta especial 6X13 SP 1,8
30	28.25650.000	1		Seeger 261	Seeger 261	Seeger 261	Seegerring 261	Seeger 261
31	021.37.032.50.00	1		Staffa valvola aria	Air valve bracket	Bride soupape air	Luftventil	Válvula aire
32	11.48025.000	1		Bullone 6x16 RS CH8	Bolt 6x20 RS CH8	Boulon 6x20 RS CH8	Bolzen 6x20 RS CH8	Tornillo 6x20 RS CH8
33	021.37.034.80.00	1		Protezione silenziatore	Silencer guard	Protection silencieux	Endschalldämpferschutz	Protección silenciador
34	C24.65.026.00.00	2		Vite ISO 7380 M5x10 10.9	Screw ISO 7380 M5x10 10.9	Vis ISO 7380 M5x10 10.9	Schraube ISO 7380 M5x10 10.9	Tornillo ISO 7380 M5x10 10.9
35	021.37.035.00.00	1		Protezione calore	Heat protection	Protection thermique	Hitzeschutz	Protección calor
36	15.14268.000	1		Fascetta passacavo aperta	Grommet clamp open	Collier passe-câble ouvert	Offene Schelle Kabeldurchgang	Abrazadera dasacables abierta

Tav.38

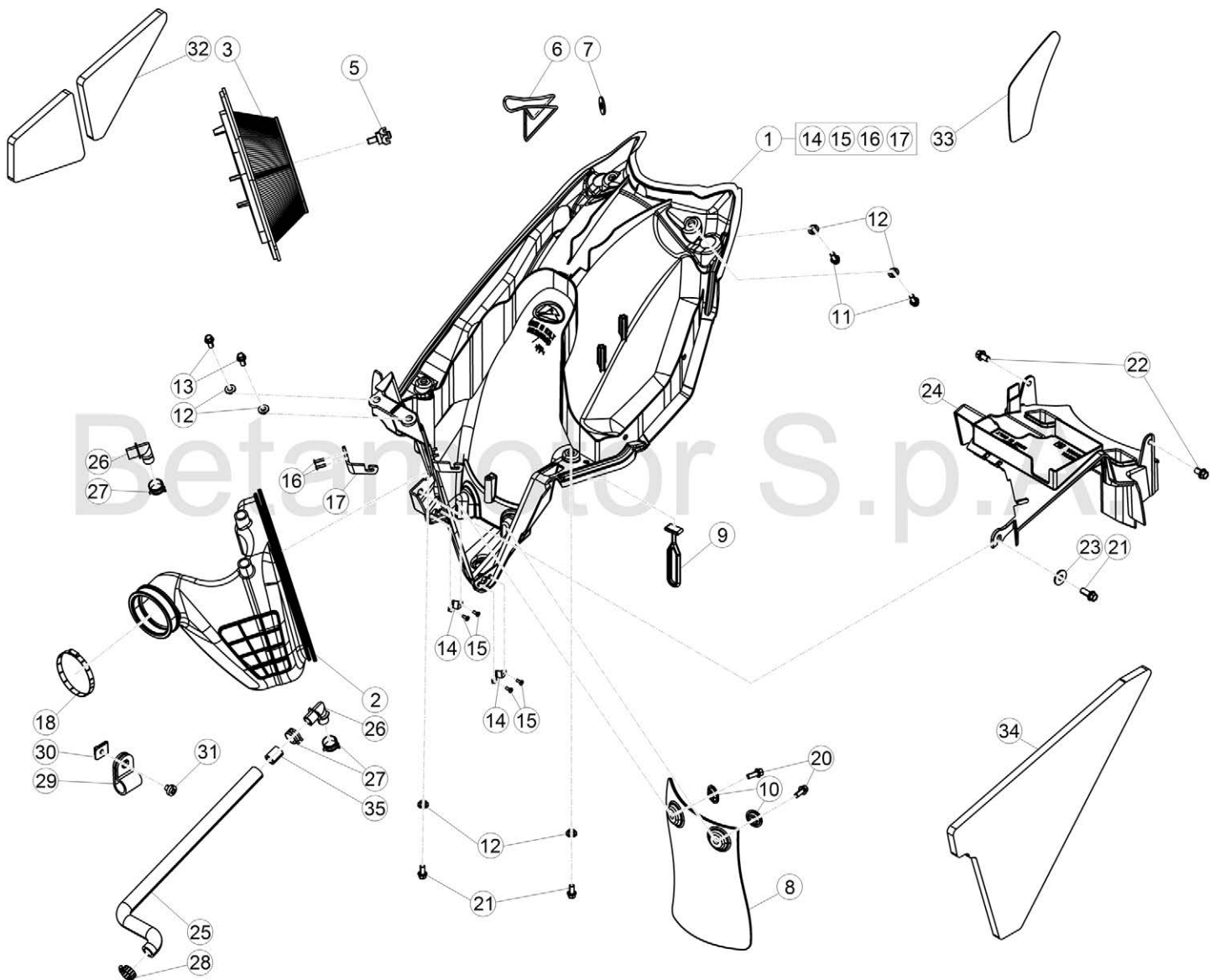

© Copyright 2019 Betamotor S.p.A.



Beta
motorcycles

Tav.38

Pos Loc Pos Ps Pos	Numero Number Numéro Número Nummer	Q.tà Q.ty Q.té M.ge C.ad	Nota Note Note Nota Anm.	Descrizione	Description	Désignation	Beschreibung	Descrìcion
1	026.38.012.80.59	1		Scatola filtro	Air cleaner box	Boîtier filtre à air	Luftfiltergehäuse	Caja filtro de aire
2	021.38.022.00.59	1		Manicotto scatola filtro	Filter box sleeve	Manchon boîte du filtre	Filtergehäusemuffe	Manguito caja filtro
3	021.38.019.00.00	1		Filtro aria	Air filter	Filtre à air	Luftfilter	Filtro de aire
5	25.57197.000	1		Perno richiamo ferma-filtro	Filter pin	Pivot filtre	Filtershalter	Pin Eje filtro
6	020.38.021.00.00	1		Molla fermafiltro	Filter spring	Ressort filtre	Filter Feder	Muelle filtro
7	27.74800.000	1		Rondella autobloccante 9	Washer 9	Rondelle 9	Scheibe 9	Arandela 9
8	036.38.009.10.59	1		Protezione ammortizzatore	Shock absorber guard	Protection amortisseur	Stossdämpferschutz	Protección amortiguador
9	16.34907.000	1		Gommino	Rubber buffer	Caoutchouc	Gummi	Goma
10	27.74786.000	2		Rondella bombata	Kasher	Rondelle	Scheibe	Arandela
11	31.79960.000	2		Vite autofilettante M6x15	Self tapping screw M6x15	Vis taraud M6x15	Schraube, Blech M6x15	Tornillo autorrosc. M6x15
12	13.54820.000	7		Distanziale 6,5x9,0x13,5	Spacer 6,5x9,0x13,5	Entretoise 6,5x9,0x13,5	Distanzstück 6,5x9,0x13,5	Distanciador 6,5x9,0x13,5
13	11.47015.000	2		Bullone M6x12	Bolt M6x12	Boulon M6x12	Bolzen M6x12	Tornillo M6x12
14	026.38.004.00.00	2		Ricettacolo	Receptacle	Réceptacle	Behälter	Receptaculo
15	C18.19.009.00.00	4		Rivetto a strappo 2,5x8	Rivet 2,5x8	Rivet 2,5x8	Niet 2,5x8	Remache 2,5x8
16	27.33803.000	2		Rivetto a strappo 3,2.11 acciaio	Rivet 3,2.11	Rivet 3,2.11	Niet 3,2.11	Remache 3,2.11
17	020.38.002.00.00	1		Staffa aggancio molla filtro	Bracket filter spirng	Plaqueette accroch. ressort filtre	Plättchen Federanlenkung	Placa eng. muelle filtro
18	15.14272.000	1		Fascetta	Clamp	Collier	Schelle	Abrazadera
20	31.79960.000	2		Vite autofilettante M6x15	Self tapping screw M6x15	Vis taraud M6x15	Schraube, Blech M6x15	Tornillo autorrosc. M6x15
21	11.48025.000	3		Bullone 6x16 ch 8 rs	Bolt 6x16 ch 8 rs	Boulon 6x16 ch 8 rs	Bolzen 6x16 ch 8 rs	Tornillo 6x16 ch 8 rs
22	11.46501.000	2		Bullone M6x10	Bolt M6x10	Boulon M6x10	Bolzen M6x10	Tornillo M6x10
23	27.42000.000	1		Rondella 6x18	Washer 6x18	Rondelle 6x18	U.Scheibe 6x18	Arandela 6x18
24	021.38.010.10.59	1		Coperchio scatola filtro	Filter case cover	Couvercle boîte filtre	Filtergehäusedeckel	Tapa caja filtro
25	021.38.004.00.00	1		Tube Sfiato Motore	Engine Breather Tube	Tube Moteur	Motorentlüftungsschlauch	Tube Motor
26	27.11020.000	2		Raccordo 90°	Joint p. 90°	Raccord 90°	Stutzen 90°	Racor 90°
27	10.67470.000	3		Anello stringitubo	Pipe clamping ring	Anneau serre-tube	Schlauchschele	Anillo prensatubo
28	15.15320.000	1		Anello stringitubo	Pipe clamping ring	Anneau serre-tube	Schlauchschele	Anillo prensatubo
29	25.25182.000	1		Fascetta	Clamp	Collier	Schelle	Abrazadera
30	25.58090.000	1		Piastrina elastica	Spring plate	Plaqueette élastique	Plättchen	Pletina elástica
31	31.23500.000	1		Vite autofilettante 4.2x13	Self tapping screw 4.2x13	Vis taraud 4.2x13	Schraube, Blech 4.2x13	Tornillo autorrosc. 4.2x13
32	021.38.005.00.00	1		Insonorizzante destro	RH sound-proofing panel	Insonorisant droit	Schalldämpfend rechts	Insonorizador der.
33	021.38.006.00.00	1		Protezione Calore	Heat protection	Protection thermique	Hitzeschutz	Protección calor
34	036.38.005.00.00	1		Spugna	Sponge	Eponge	Schwamm	Esonja
35	27.31780.000	1		Riduzione fumi	Reducteur de la fumée	Reduction of fumes	Rauchreduzierung	Reductor del humo

Tav.39

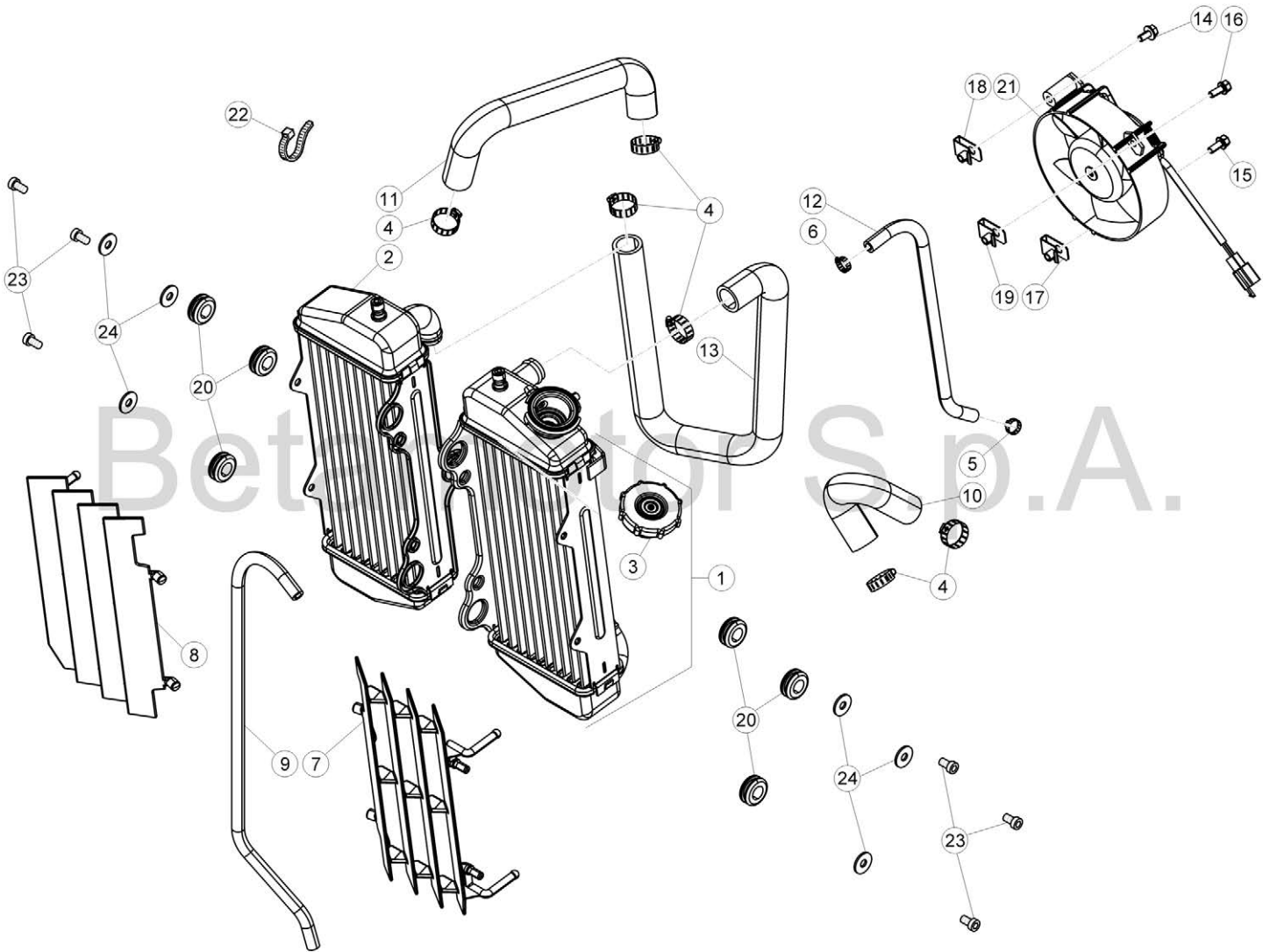

© Copyright 2017 Betamotor S.p.A.

Tav.39

Pos Loc Ps Pos	Numero Number Numéro Número Nummer	Q.tà Q.ty Q.té M.ge C.ad	Nota Note Note Nota Anm.	Descrizione	Description	Désignation	Beschreibung	Descripcìon
1	021.39.001.00.00	1		Radiatore Sx	L.H. radiator	Radiateur G.	L., Kühler	Radiador iz.
2	021.39.000.00.00	1		Radiatore Dx	R.H. radiator	Radiateur D.	R., Kühler	Radiador der.
3	021.39.020.00.00	1		Tappo radiatore	Radiator plug	Bouchon radiateur	Kühlerdeckel	Tapa de radiador
4	15.15240.000	6		Fascetta 19/28	Clamp 19/28	Collier 19/28	Schelle 19/28	Abrazadera 19/28
5	C07.16.004.00.00	1		Fascetta d 11,3	Clamp d 11,3	Collier d 11,3	Schelle d 11,3	Abrazadera d 11,3
6	10.67460.000	1		Anello stringitubo	Pipe clamping ring	Anneau serre-tube	Schlauchschelle	Anillo prensatubo
7	021.39.015.00.59	1		Griglia radiatore sx.	LH Radiator grille	Calandre G.	Kühlergrill links	Reja del radiador izq.
8	021.39.014.00.59	1		Griglia radiatore dx.	RH Radiator grille	Calandre D.	Kühlergrill rechts	Reja del radiador der.
9	021.39.006.00.00	1		Tube sfciato radiatore	Radiator breather pipe	Tuyau vidange radiateur	Kühlerentlüftungsrohr	Tube ventilación radiador
10	021.39.004.00.00	1		Tube pompa acqua	Water pump pipe	Tube pompe eau	Leitung wasserpumpe	Tube bomba agua
11	021.39.008.00.00	1		Tube termostato	Thermostat hose	Tube interrupteur thermique	Thermostatschlauch	Tube termostato
12	021.39.013.00.00	1		Tube acqua	Water pipe	Tuyau de l'eau	Kühlflüssigkeitsleitung	Tube agua
13	021.39.012.00.00	1		Tube acqua	Water pipe	Tuyau de l'eau	Kühlflüssigkeitsleitung	Tube agua
14	31.29885.000	1		Vite M5x35	Screw M5x35	Vis M5x35	Schraube M5x35	Tornillo M5x35
15	31.29850.000	1		Vite t.t.l.c. M5x12	Screw t.t.l.c. M5x12	Vis t.t.l.c. M5x12	Schraube t.t.l.c. M5x12	Tornillo t.t.l.c. M5x12
16	31.29850.000	1		Vite t.t.l.c. M5x12	Screw t.t.l.c. M5x12	Vis t.t.l.c. M5x12	Schraube t.t.l.c. M5x12	Tornillo t.t.l.c. M5x12
17	25.58065.000	1		Clip M5	Clip M5	Clip M5	Clip M5	Clip M5
18	25.58065.000	1		Clip M5	Clip M5	Clip M5	Clip M5	Clip M5
19	25.58065.000	1		Clip M5	Clip M5	Clip M5	Clip M5	Clip M5
20	28.92101.000	6		Silent block marmitta	Silencer puffer	Silent block silencieux	Silent block Auspuff	Silent block escape
21	021.39.002.00.00	1		Elettroventola	Electric fan	Electro-ventilateur	Elektroluterrad	Electroventilador
22	15.14264.000	1		Fascetta	Clamp	Collier	Schelle	Abrazadera
23	31.30200.000	6		Vite a brugola TCCE 6x10	Allen screw TCCE 6x10	Vis à 6 pans TCCE 6x10	Sechskantschraube TCCE 6x10	Tornillo a llave allen TCCE 6x10
24	27.42000.000	6		Rondella 6x18	Washer 6x18	Rondelle 6x18	U.Scheibe 6x18	Arandela 6x18

GR. COMPONENTI ELETTRICI/CABLAGGI

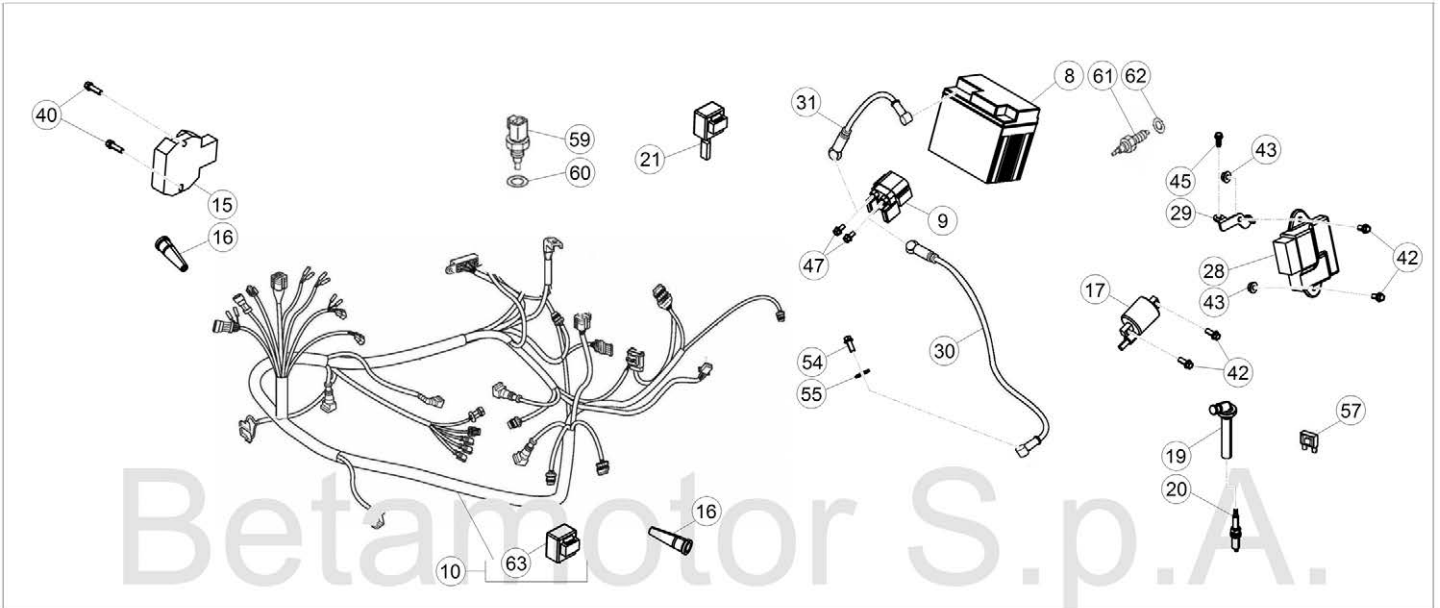

GR. LUCI/INDICATORI

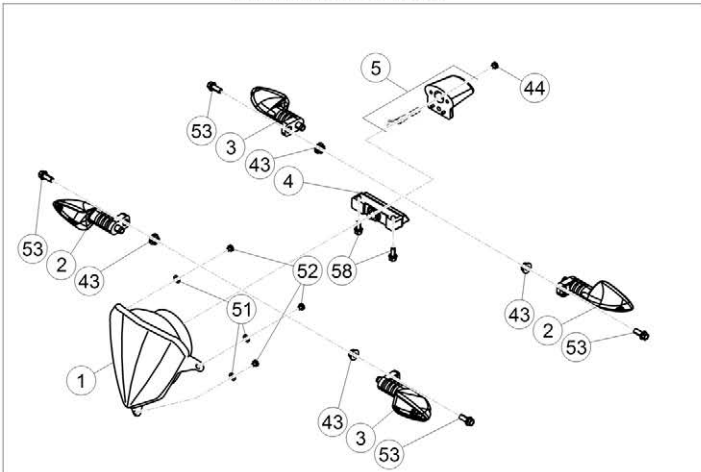

GR. STRUMENTAZIONE

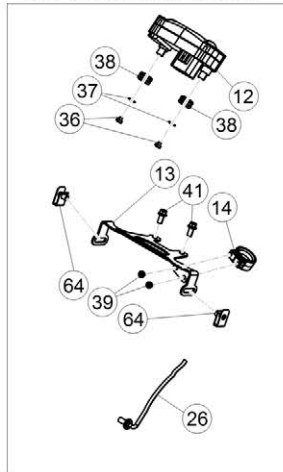

GR. ACCESSORI

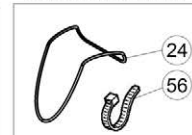

GR. AVV. ACUSTICO

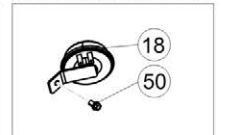

GR. COMMUTATORE

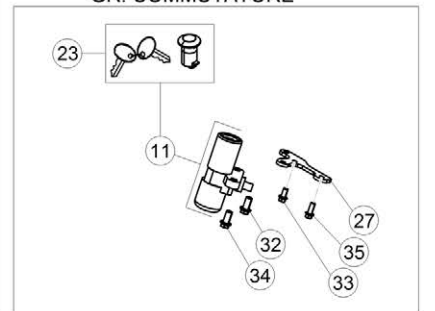

© Copyright 2019 Betamotor S.p.A.

Tav.40

Pos Loc Pos Ps Pos	Numero Number Numéro Número Nummer	Q.tà Q.ty Q.té M.ge C.ad	Nota Note Note Nota Anm.	Descrizione	Description	Désignation	Beschreibung	Descripción
1	031.40.006.00.00	1		Gruppo ottico	Headlamp	Projecteur	Scheinwerfer	Faro del.
2	020.40.060.00.00	2		Indicatore anteriore dx.- posteriore sx.	Front RH.-Rear LH blinker	Clignotant D. avant-G. arrière	Vordere R.-Hintere L. Blinker	Intermittente D. delantero-l. trasero
3	020.40.061.00.00	2		Indicatore anteriore sx.- posteriore dx.	Front LH.-Rear RH blinker	Clignotant G. avant-D. arrière	Vordere L.-Hintere R. Blinker	Intermittente l. delantero-D. trasero
4	020.40.030.80.00	1		Fanalino posteriore a led	LED tail lamp	Feu AR. à diodes	LED-Rücklicht	Piloto a LED
5	024.40.053.00.00	1		Luce Targa	Plate Illumination	Éclairage De Plaque	Kennzeichen-Beleuchtung	Iluminación Placa
8	11.15415.000	1		Batteria	Battery	Batterie	Batterie	Bateria
9	27.28471.000	1		Relais	Relay	Relais	Relay	Relé
10	021.40.023.00.00	1		Impianto elettrico principale	Main electric equipment	Installation centrale	Zentraler Kabelbaum	Instalacion electrica central
11	021.40.040.80.00	1		Commutatore a chiave	Key operated switch	Commutateur à clef	Zündschalter	Conmutador de llave
12	021.40.011.00.00	1	ENDURO	Strumento digitale	Digital dashboard	Instrument numérique	Digitalinstrument	Instrumento digital
12	021.40.133.83.00	1	MOTARD	Strumento digitale	Digital dashboard	Instrument numérique	Digitalinstrument	Instrumento digital
13	021.40.013.40.26	1		Supporto strumento digitale	Digital dashboard bracket	Support instrument numérique	Halter für Digitalinstrument	Soporte instrumento digital
14	25.24464.000	1		Passacavo	Grommet	Passe-cable	Kabeldurchgang	Pasacable
15	021.40.050.00.00	1		Regolatore	Regulator	Régulateur	Regler	Regulador
16	18.87010.000	1		Interruttore stop	Stop switch	Interrupteur stop	Stopschalter	Interruptor stop
17	021.40.051.82.00	1		Bobina	Coil	Bobine	Spule	Bobina
18	007.40.050.00.00	1		Avvisatore acustico	Warning horn	Avertisseur sonore	Hupe	Claxon
19	27.13552.000	1		Raccordo candela	Plug fitting	Raccord bougie	Kerzenanschluß	Racor bujia
20	021.11.008.00.00	1		Candela NGK CR8E	Spark plug NGK CR8E	Bougie NGK CR8E	Zündkerze NGK CR8E	Bujia NGK CR8E
21	18.84948.000	1		Intermittenza	Unit turn signal lamps	Disp. comm. clignot.	Blinkgeber	Disp. intermitentes
23	021.40.041.82.00	1		Serratura	Lock	Serrure	Schloß	Cerradura
24	14.40020.000	1		Cinghia fiss. batteria	Battery sec. strap	Bande fix. batterie	Batteriebefestigung Riemen	Correja suj. batería
26	28.79013.000	1		Sensore Reed	Reed sensor	Capteur Reed	Senor Reed	Sensor Reed
27	024.40.018.50.00	1		Supporto commutatore	Key operated switch bracket	Support commutateur à clef	Halter für Zündschalter	Soporte conmutador de llave
28	021.40.008.00.00	1		Centralina	Electronic control unit	Unité de commande	Zündbox	Central
29	021.40.022.50.00	1		Staffa centralia	ECU bracket	Bride centrale électronique	Klammer für elektronisches Steuergerät	Brida centralita electrónica
30	021.40.057.00.00	1		Impianto elettrico relé	Relay harness	Installation électrique relais	Elektrische Anlage Relais	Sistema electrico relé
31	020.40.003.00.00	1		Cavo batteria-relè	Battery-Relay cable	Cable batterie-relais	Kabel Batterie-Relais	Cable Bateria-Relé
32	31.63925.000	1		Vite a strappo M8X18	Shear rivet M8X18	Vis a rupture M8X18	Bruchschraube M8X18	Remache M8X18
33	11.48025.000	1		Bullone 6x16 ch 8 rs	Bolt 6x16 ch 8 rs	Boulon 6x16 ch 8 rs	Bolzen 6x16 ch 8 rs	Tornillo 6x16 ch 8 rs
34	31.63880.000	1		Vite 8x16 TCCE	Screw 8x16 TCCE	Vis 8x16 TCCE	Schraube 8x16 TCCE	Tornillo 8x16 TCCE
35	31.30590.000	1		Vite M6x14	Screw M6x14	Vis M6x14	Schraube M6x14	Tornillo M6x14
36	31.23566.000	2		Vite autofilettante 4,5x9	Self tapping screw 4,5x9	Vis taraud 4,5x9	Schraube, Blech 4,5x9	Tornillo autorrosc. 4,5x9
37	27.36500.000	2		Rondella Ø5	Washer Ø5	Rondelle Ø5	U.Scheibe Ø5	Arandela Ø5
38	024.40.039.00.00	2		Silentbloc	Silentbloc	Silentbloc	Puffer	Silent-block
39	31.30566.000	2		Vite M4,5x9	Screw M4,5x9	Vis M4,5x9	Schraube M4,5x9	Tornillo M4,5x9
40	11.49070.000	2		Bullone 6x20 ch rs	Bolt 6x20 ch rs	Boulon 6x20 ch rs	Bolzen 6x20 ch rs	Tornillo 6x20 ch rs
41	11.47015.000	2		Bullone M6x12	Bolt M6x12	Boulon M6x12	Bolzen M6x12	Tornillo M6x12
42	11.48025.000	4		Bullone 6x16 ch 8 rs	Bolt 6x16 ch 8 rs	Boulon 6x16 ch 8 rs	Bolzen 6x16 ch 8 rs	Tornillo 6x16 ch 8 rs
43	13.12550.000	6		Dado flangiato M6	Flanged nut M6	Ecrou bordé M6	Flanschmutter M6	Tuerca embreadada M6
44	31.23565.000	1		Vite 4,5x15 TCCCR	Screw 4,5x15 TCCCR	Vis 4,5x15 TCCCR	Schraube 4,5x15 TCCCR	Tornillo 4,5x15 TCCCR
45	31.79960.000	1		Vite autofilettante M6x15	Self tapping screw M6x15	Vis taraud M6x15	Schraube, Blech M6x15	Tornillo autorrosc. M6x15
47	31.30190.000	2		Vite a brugola 6x8	Allen screw 6x8	Vis à 6 pans 6x8	Sechskantschraube 6x8	Tornillo a llave allen 6x8
50	11.46501.000	1		Bullone M6x10	Bolt M6x10	Boulon M6x10	Bolzen M6x10	Tornillo M6x10
51	27.34650.000	3		Rondella	Washer	Rondelle	U.Scheibe	Arandela
52	31.26190.000	3		Vite M4x12 TCIC	Screw M4x12 TCIC	Vis M4x12 TCIC	Schraube M4x12 TCIC	Tornillo M4x12 TCIC
53	11.48025.000	4		Bullone 6x16 ch 8 rs	Bolt 6x16 ch 8 rs	Boulon 6x16 ch 8 rs	Bolzen 6x16 ch 8 rs	Tornillo 6x16 ch 8 rs
54	31.29900.000	1		Vite brugola 5x10	5x10	5x10	U.Scheibe 5x10	5x10
55	27.36000.000	1		Rondella 5x11	Washer 5x11	Rondelle 5x11	U.Scheibe 5x11	Arandela 5x11
56	15.14264.000	1		Fascetta	Clamp	Collier	Schelle	Abrazadera
57	020.40.006.00.00	2		Fusibile 10 A	Fuse 10 A	Fusible 10 A	Sicherung 10 A	Fusibile 10 A
58	11.46251.000	2		Bullone flangiato M5x12	Head Flanged bolt M5x12	Boulon Bridé M5x12	Bundbolzen M5x12	Bulón con Brida M5x12
59	021.40.054.00.00	1		Sensore temperatura acqua	Water temperature sensor	Capteur température eau	Wassertemperaturfühler	Sensor temperatura de agua
60	021.07.019.00.00	1		Rondella	Washer	Rondelle	U.Scheibe	Arandela
61	021.40.053.00.00	1		Sensore folle	Neutral sensor	Capteur de point mort	Leerlaufsensor	Sensor punto muerto
62	021.40.055.00.00	1		Guarnizione rame	Copper gasket	Joint cuivre	Kupferdichtung	Junta de cobre
63	27.28462.000	1		Relais	Relay	Relais	Relay	Relé
64	25.60311.000	2		Piastrina elastica M6	Spring plate M6	Plaquette élastique M6	Plättchen M6	Pletina elástica M6

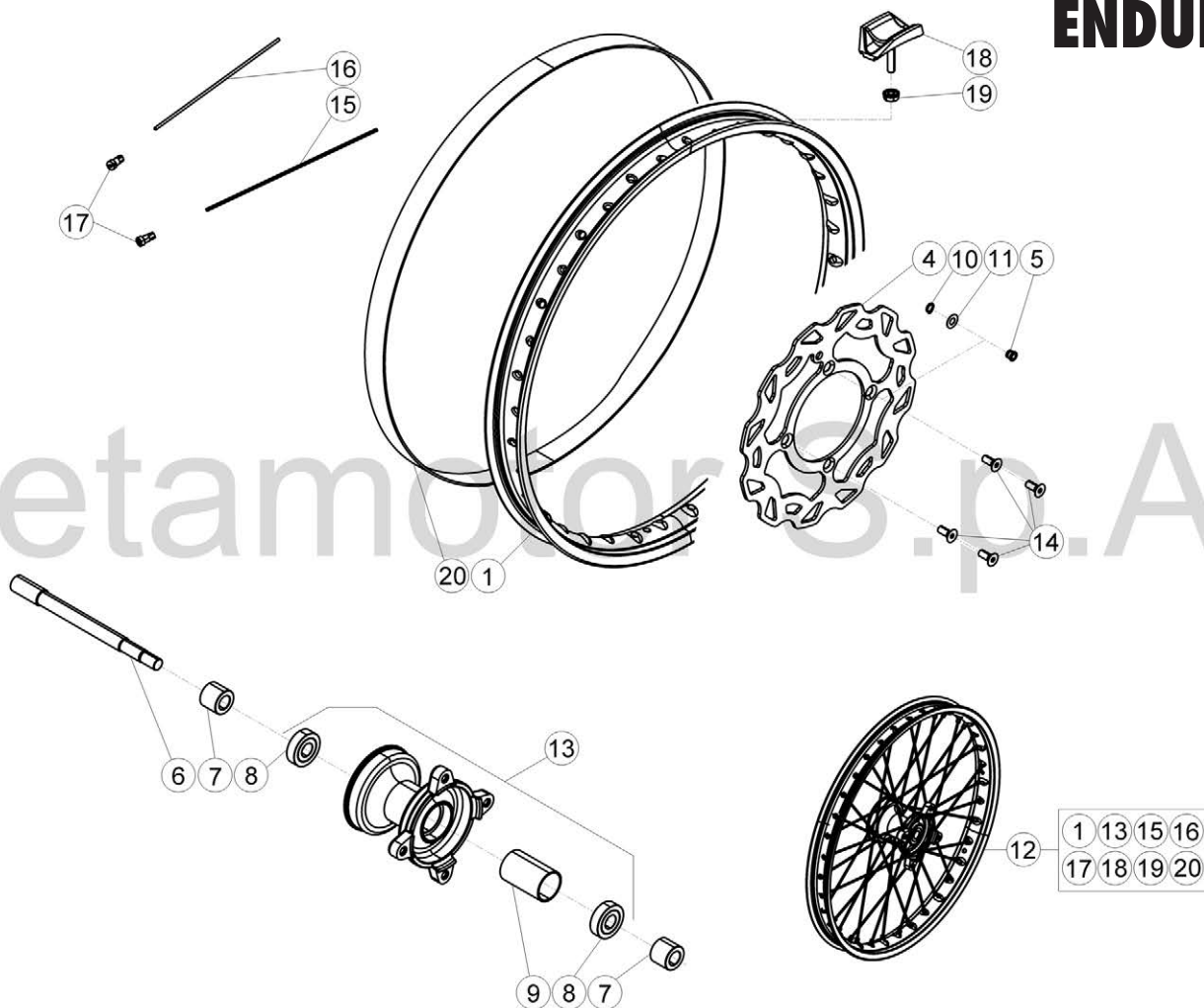

© Copyright 2017 Betamotor S.p.A.

Pos	Numero	Q.tà	Nota	Descrizione	Description	Désignation	Beschreibung	Descripcìon
Loc	Number	Q.ty	Note					
Pos	Numéro	Q.té	Note					
Ps	Número	M.ge	Nota					
Pos	Nummer	C.ad	Anm.					
1	021.41.010.00.59	1		Cerchio anteriore	Front rim	Jante roue AV.	Vorderfelge	Aro delantero
4	024.41.001.00.00	1		Disco freno anteriore	Front brake disk	Disque Frein AV.	Vordere Bremsscheibe	Dsco freno del.
5	021.41.005.00.00	1		Magnete	Magneto	Magneto	Magnet	Magneto
6	021.41.001.00.00	1		Asse ruota	Wheel axle	Axe roue	Radachse	Eje rueda
7	13.85737.000	2		Distanziale mozzo ant.	Spacer front hub	Entretoise moyeu avant	Distanzscheibe	Dist. buje del.
8	12.96005.000	2		Cuscinetto 17x40x12	Bearing 17x40x12	Roulement 17x40x12	Lager 17x40x12	Cojinete 17x40x12
9	13.62728.000	1		Distanziale int, mozzo anter.	Front hub inner spacer	Entretoise int. moyeu avant	Distanciador int buje del.	Distanciador int. buje del.
10	28.22660.000	1		Seeger 9E	Seeger 9E	Seeger 9E	Seegerring 9E	Seeger 9E
11	27.58080.000	1		Rondella spess. 9x13x0,4	Washer 9x13x0,4	Rondelle epaisseur 9x13x0,4	Scheibe 9x13x0,4	Arandela 9x13x0,4
12	021.41.122.00.59	1		Ruota anteriore premontata	Rear wheel assy.	Roue avant p/motée	Vormontiertes vorderrad	Rueda delantera montada
13	014.41.104.00.00	1		Mozzo anteriore	Fr. hub	Moyeu AV.	Nabe	Buje del.
14	31.63922.000	4		Vite TSPCE 8x16	Screw 8x16	Vis 8x16	Schraube 8x16	Tornillo
15	27.23981.000	18		Raggio 3x240	Spoke 3x240	Rayon 3x240	Speiche 3x240	Rayo 3x240
16	27.23982.000	18		Raggio 3x238	Spoke 3x238	Rayon 3x238	Speiche 3x238	Radio 3x238
17	23.10100.000	36		Nipples	Nipples	Nipples	Nippel	Nipples
18	15.17500.000	1		Fermafascioni	Tire fastener	Caoutchouc serrure chambre	Reifen Halter	Agarre cubierta ant.
19	13.17120.000	1		Dado M8 flangiato	Nut M8	Eccrou M8	Mutter M8	Tuerca M8
20	15.38200.000	1		Flap 21x25	Bead 21x25	Flap21x25	Felgenband 21x25	Flap cinta tapa radios 21.25



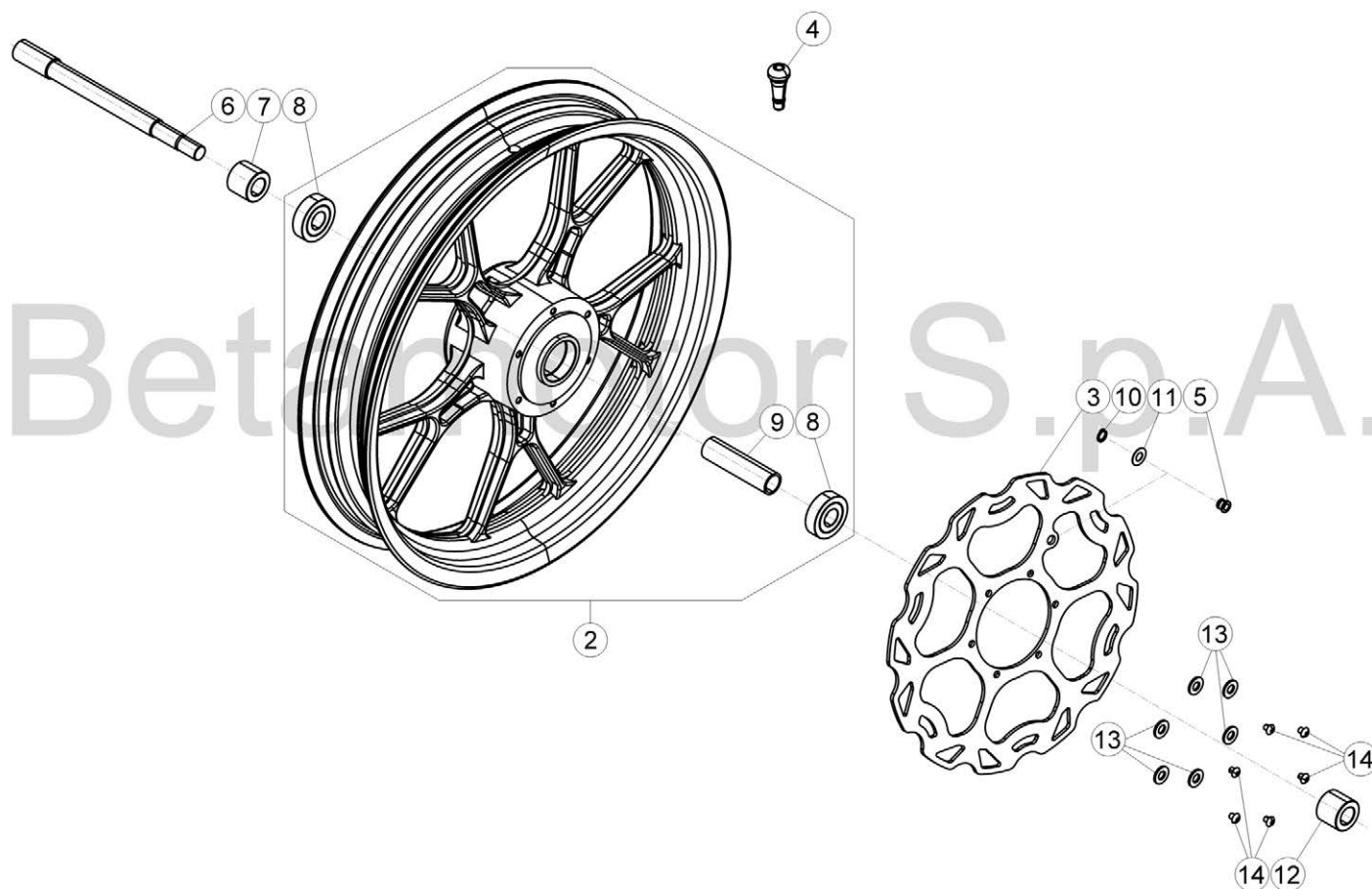

© Copyright 2017 Betamotor S.p.A.

Pos	Numero	Q.tà	Nota	Descrizione	Description	Désignation	Beschreibung	Descripcìon
Loc	Number	Q.ty	Note					
Pos	Numéro	Q.té	Note					
Ps	Número	M.ge	Nota					
Pos	Nummer	C.ad	Anm.					
2	024.41.016.00.59	1		Cerchio anteriore	Front rim	Jante avant	Vorder Felge	Llanta delant.
3	024.41.201.00.00	1		Disco freno anteriore	Front brake disk	Disque Frein AV.	Vordere Bremsscheibe	Dsco freno del.
4	31.10000.000	1		Valvola aria tbl.	Tubeless valve	Valve pour tubeless	Ventil für schlauchlosen Reifen	Válvula para tubeless
5	021.41.005.00.00	1		Magnete	Magneto	Magneto	Magnet	Magneto
6	021.41.001.00.00	1		Asse ruota	Wheel axle	Axe roue	Radachse	Eje rueda
7	021.41.004.00.00	1		Distanziale	Spacer	Entretoise	Distanzstück	Distanciador
8	12.96005.000	2		Cuscinetto 17x40x12	Bearing 17x40x12	Roulement 17x40x12	Lager 17x40x12	Cojinete 17x40x12
9	024.41.071.00.00	1		Distanziale interno	Inner spacer	Entretoise interne	Inneres Distanzstück	Distanciador interior
10	28.22660.000	1		Seeger 9E	Seeger 9E	Seeger 9E	Seegerring 9E	Seeger 9E
11	27.58080.000	1		Rondella spess. 9x13x0,4	Washer 9x13x0,4	Rondelle epaisseur 9x13x0,4	Scheibe 9x13x0,4	Arandela 9x13x0,4
12	021.41.003.00.00	1		Distanziale (lato disco)	Spacer (disc side)	Entretoise (côté disque)	Distanzstück (Scheibe Seite)	Distanciador (lado disco)
13	27.40470.000	6		Rondella 6,4x10x0,7	Washer 6,4x10x0,7	Rondelle 6,4x10x0,7	U.Scheibe 6,4x10x0,7	Arandela 6,4x10x0,7
14	31.30780.000	6		Vite M6x20	Screw M6x20	Vis M6x20	Schraube M6x20	Tornillo M6x20

Betamotor S.p.A.

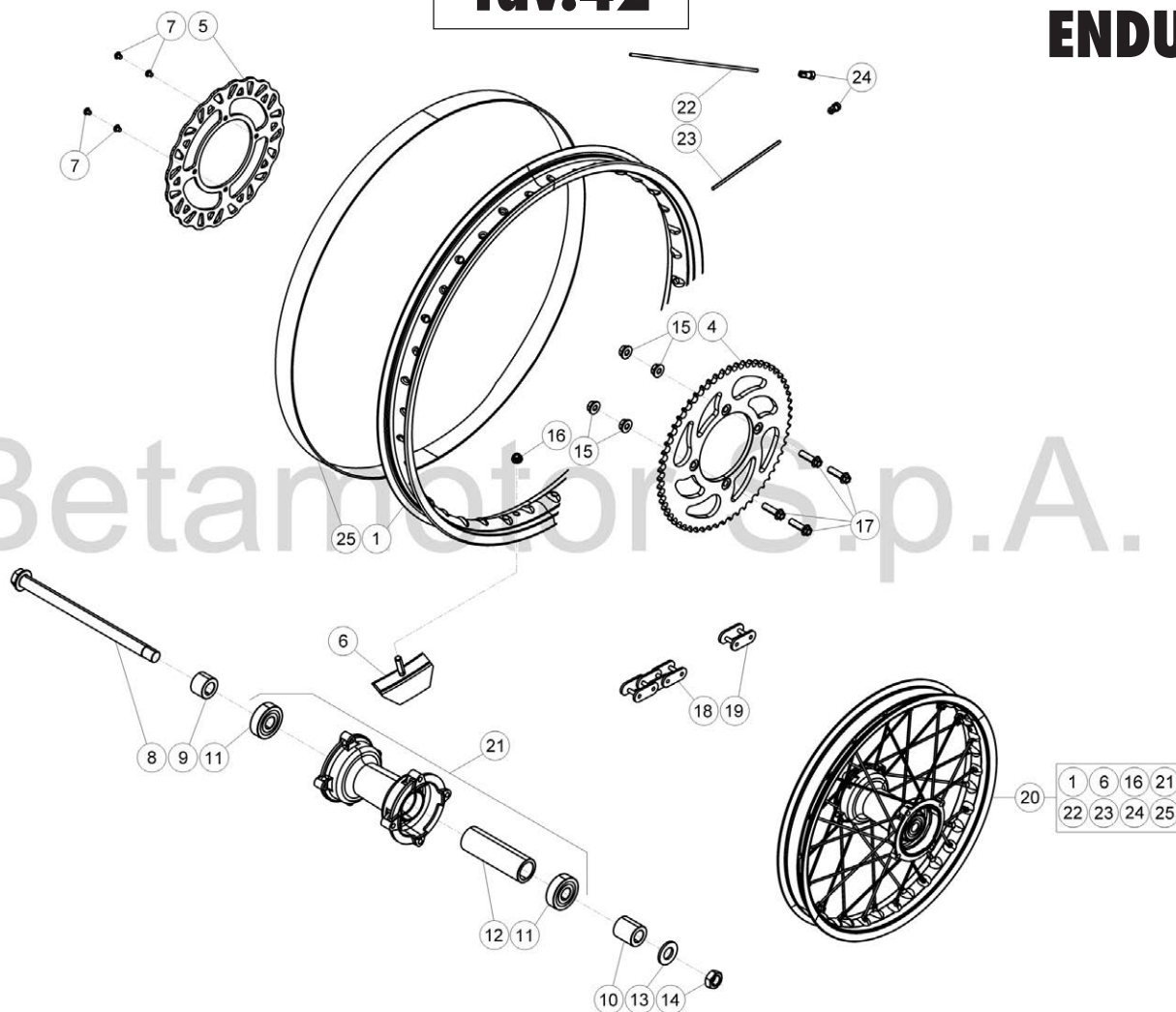

© Copyright 2017 Betamotor S.p.A.

Pos Loc	Numero Number	Q.tà Q.ty	Nota Note	Descrizione	Description	Désignation	Beschreibung	Descripción
1	021.42.020.00.59	1		Cerchio posteriore	Rear rim	Jante arrière	Hinten Felge	Llanta tras.
4	021.42.005.00.00	1		Corona z63	Ring gear z63	Couronne z63	Zahnkranz z63	Corona z63
5	024.42.001.00.00	1		Disco freno posteriore	Rear brake disk	Disque frein arrière	Hinterbremscheibe	Disco freno trasero
6	15.17550.000	1		Fermafascioni	Tire fastener	Caoutchouc serrure chambre	Reifen Halter	Agarre cubierta ant.
7	31.30785.000	4		Vite TBEI M6x20	Screw TBEI M6x20	Vis TBEI M6x20	Schraube TBEI M6x20	Tornillo TBEI M6x20
8	021.42.003.00.00	1		Perno ruota posteriore	Rear wheel pin	Pivot roue arrière	Hinterradbolzen	Perno rueda trasera
9	021.42.002.00.00	1		Distanziale (lato disco)	Spacer (disc side)	Entretoise (côté disque)	Distanzstück (Scheibe Seite)	Distanciadador (lado disco)
10	021.42.004.00.00	1		Distanziale (lato corona)	Spacer (ring gear side)	Entretoise (côté couronne)	Distanzstück (Kranz Seite)	Distanciadador (lado corona)
11	12.97005.000	2		Cuscinetto stagno 17x47x14	Ball bearing 17x47x14	Roulement etanche 17x47x14	Kugellager 17x47x14	Cojinete blindado 17x47x14
12	13.62727.000	1		Distanziale interno	Inner spacer	Entretoise interne	Inneres Distanzstück	Distanciadador interior
13	27.71210.000	1		Rondella 17x33x3	Washer 17x33x3	Rondelle 17x33x3	Scheibe 17x33x3	Arandela 17x33x3
14	13.29600.000	1		Dado 16x1,5	Nut 16x1,5	Ecrou 16x1,5	Mutter 16x1,5	Tuerca 16x1,5
15	13.17031.000	4		Dado M8 autobloc -conelock-	Nut M8	Ecrou M8	Mutter M8	Tuerca M8
16	13.17120.000	1		Dado M8 flangiato	Nut M8	Ecrou M8	Mutter M8	Tuerca M8
17	007.42.015.00.00	4		Vite TBCE M8.33	Screw TBCE M8.33	Vis TBCE M8.33	Schraube TBCE M8.33	Tornillo TBCE M8.33
18	021.42.016.00.00	1		Catena 1/2 5/16 P.140	Chain 1/2 5/16 P.140	Chaîne 1/2 5/16 P.140	Kette 1/2 5/16 P.140	Cadena 1/2 5/16 P.140
19	021.42.018.00.00	1		Maglia congiunzione 1/2x5/16	Connecting link 1/2x5/16	Maillon jonction 1/2x5/16	Kettenschloss 1/2x5/16	Enganche cadena 1/2x5/16
20	021.42.113.00.59	1		Ruota posteriore premontata	Rear wheel assy.	Roue arrière p/motée	Vormontiertes hinterrad	Rueda trasera montada
21	021.42.001.80.00	1		Mozzo completo	Hub, assy.	Moyeu compl.	Nabe, kompl.	Buje compl.
22	27.24811.000	27		Raggio 3,5x203 c.150	Spoke 3,5x203 c,150	Rayon 3,5x203 c,150	Speiche 3x203 c.150	Rayo 3,5x203 c. 150
23	27.24812.000	9		Raggio 3,5x206 c.150	Spoke 3,5x206 c,150	Rayon 3,5x206 c,150	Speiche 3x206 c.150	Rayo 3,5x206 c. 150
24	23.10110.000	36		Nipples ø3,5	Nipples ø3,5	Nipples ø3,5	Nippel ø3,5	Nipples 3,5
25	15.36000.000	1		Flap 17/18x25	Bead 17/18x25	Flap 17/18x25	Felgenband 17/18x25	Flap cinta tapa radios 17/18x25

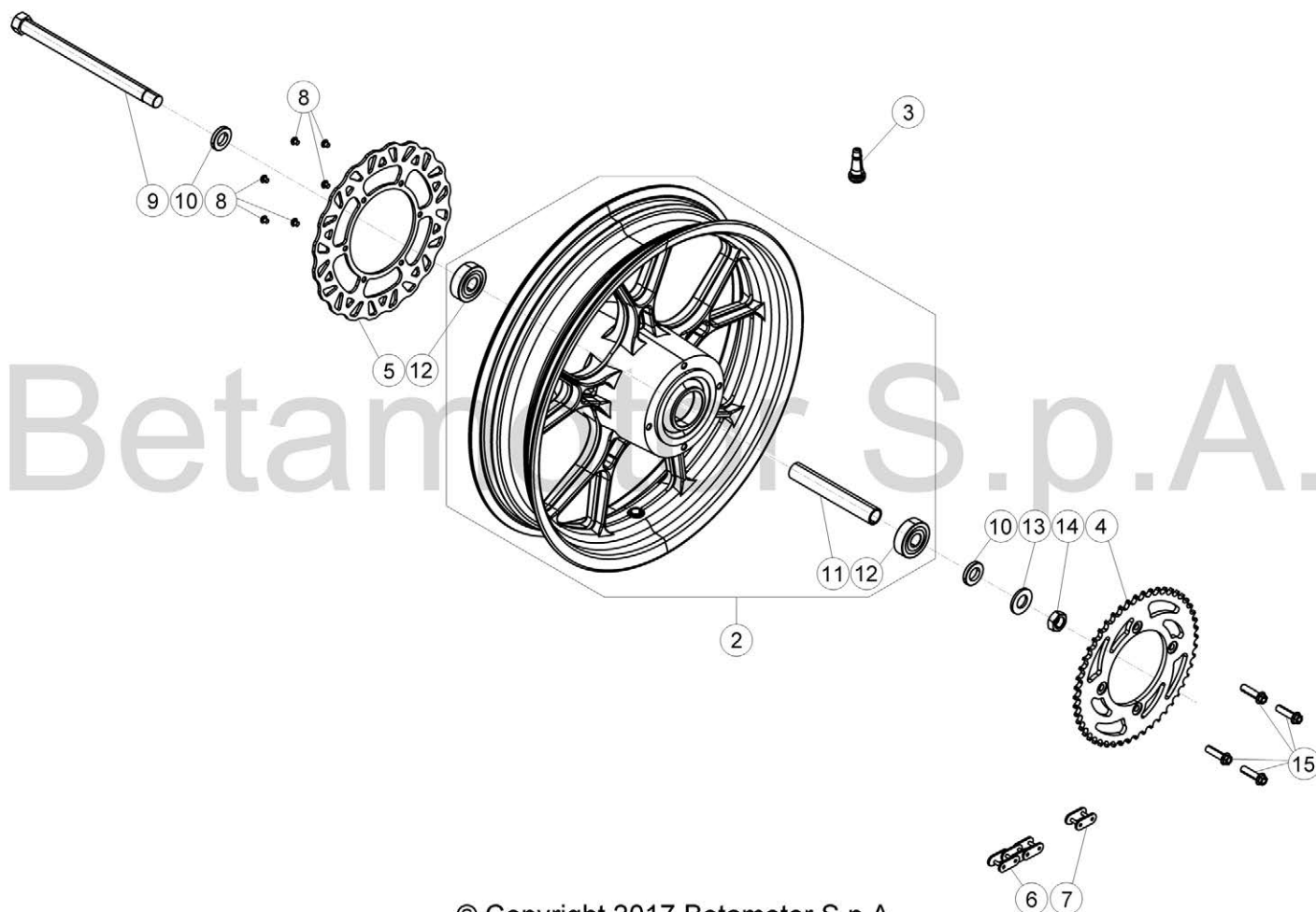

© Copyright 2017 Betamotor S.p.A.

Pos	Numero	Q.tà	Nota	Descrizione	Description	Désignation	Beschreibung	Descripcìon
Loc	Number	Q.ty	Note					
Pos	Numéro	Q.té	Note					
Ps	Número	M.ge	Nota					
Pos	Nummer	C.ad	Anm.					
2	021.42.013.00.59	1		Cerchio posteriore	Rear rim	Jante arrière	Hinten Felge	Llanta tras.
3	31.10000.000	1		Valvola aria tbl.	Tubeless valve	Valve pour tubeless	Ventil für schlauchlosen Reifen	Válvula para tubeless
4	021.42.012.00.00	1		Corona z56	Ring gear z56	Couronne z56	Zahnkranz z56	Corona z56
5	024.42.101.00.00	1		Disco freno posteriore	Rear brake disk	Disque frein arrière	Hinterbrems Scheibe	Disco freno trasero
6	021.42.017.00.00	1		Catena 1/2 5/16 P.136	Chain 1/2 5/16 P.136	Chaîne 1/2 5/16 P.136	Kette 1/2 5/16 P.136	Cadena 1/2 5/16 P.136
7	021.42.018.00.00	1		Maglia congiunzione 1/2x5/16	Connecting link 1/2x5/16	Maillon jonction 1/2x5/16	Kettenschloss 1/2x5/16	Enganche cadena 1/2x5/16
8	31.30750.000	6		Vite M6x16	Screw M6x16	Vis M6x16	Schraube M6x16	Tornillo M6x16
9	021.42.003.00.00	1		Perno ruota posteriore	Rear wheel pin	Pivot roue arrière	Hinterradbolzen	Perno rueda trasera
10	021.42.011.00.00	2		Distanziale post.	Rear spacer	Entretoise arrière	Distanzstück hinten	Distanciador tras.
11	024.42.071.00.00	1		Distanziale interno	Inner spacer	Entretoise interieur	Distanzstück	Distanciador
12	12.97005.000	2		Cuscinetto stagno 17x47x14	Ball bearing 17x47x14	Roulement etanche 17x47x14	Kugellager 17x47x14	Cojinete blindado 17x47x14
13	27.71210.000	1		Rondella 17x33x3	Washer 17x33x3	Rondelle 17x33x3	Scheibe 17x33x3	Arandela 17x33x3
14	13.29600.000	1		Dado 16x1,5	Nut 16x1,5	Ecrou 16x1,5	Mutter 16x1,5	Tuerca 16x1,5
15	31.63990.000	4		Vite 8x25	Screw 8x25	Vis 8x25	Schraube 8x25	Tornillo 8x25

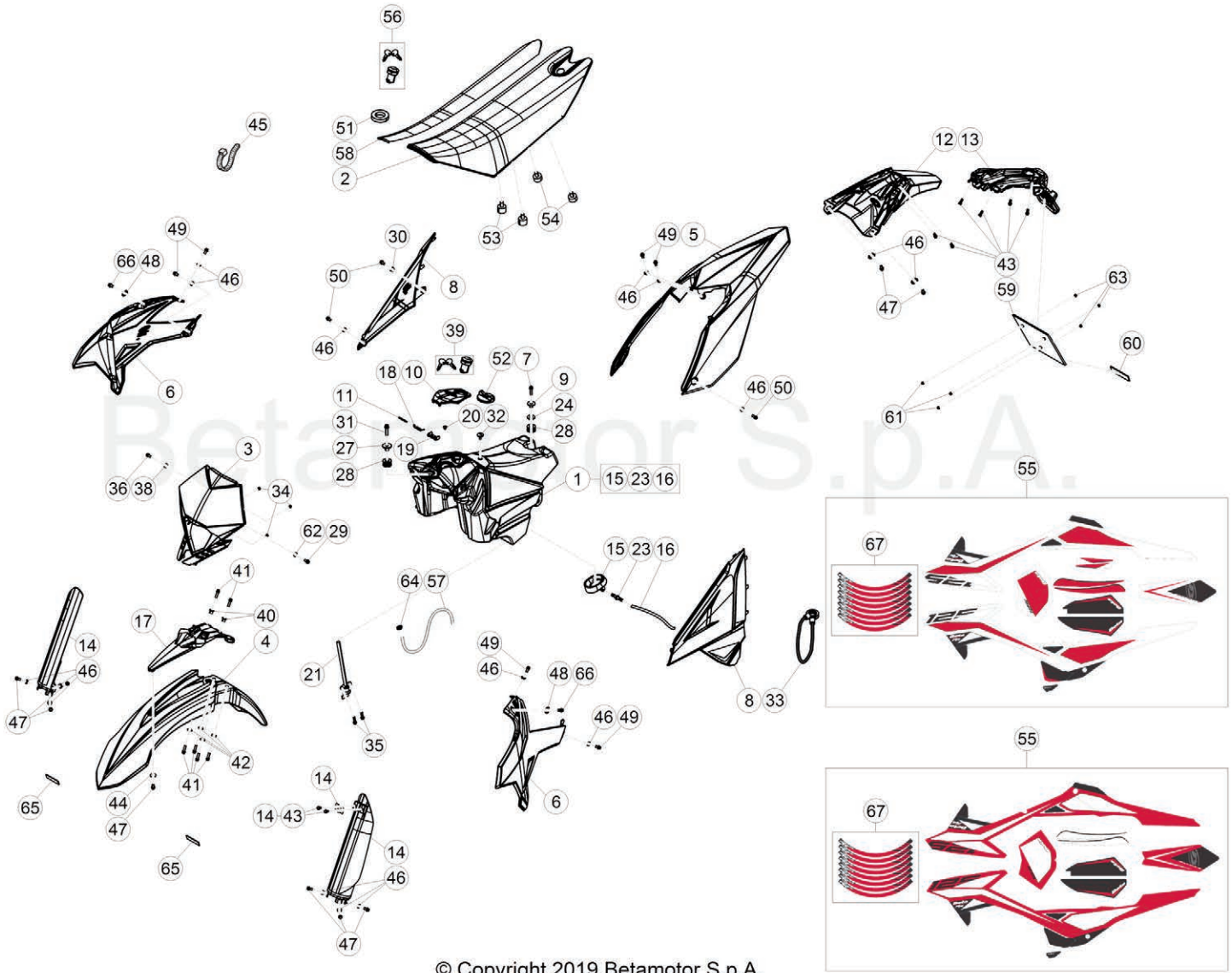

© Copyright 2019 Betamotor S.p.A.

Tav.43

Pos Loc Pos Ps Pos	Numero Number Numéro Número Nummer	Q.tà Q.ty Q.té M.ge C.ad	Nota Note Note Nota Anm.	Descrizione	Description	Désignation	Beschreibung	Descrìpziòn
								ENDURO
1	021.43.019.80.59	1		Serbatoio completo	Fuel tank	Réservoir carburant	Kraftstofftank	Depósito gasolina
2	021.43.022.00.00	1		Sella	Seat	Siege	Sattel	Sillin
3	020.43.017.87.51	1		Mascherina portafaro (BIANCO)	Headlight holder (WHITE)	Cache porte-phare (BLANC)	Lampenmaske (WEISS)	Portafaro ant. con adhesivo (BLANCO)
3	020.43.017.87.97	1		Mascherina portafaro (ROSSO)	Headlight holder (RED)	Cache porte-phare (ROUGE)	Lampenmaske (ROT)	Portafaro ant. con adhesivo (ROJO)
4	024.43.014.10.51	1		Parafango anteriore (BIANCO)	Front mudguard (WHITE)	Garde-boue AV. (BLANC)	Vorderes Schutzblech (WEISS)	Guardabarros delantero (BLANCO)
4	024.43.014.10.97	1		Parafango anteriore (ROSSO)	Front mudguard (RED)	Garde-boue AV. (ROUGE)	Vorderes Schutzblech (ROT)	Guardabarros delantero (ROJO)
5	026.43.033.00.51	1		Parafango posteriore (BIANCO)	Rear mudguard (WHITE)	Garde-boue AR. (BLANC)	Hinterradkotflügel (WEISS)	Guardabarros tras. (BLANCO)
5	026.43.033.00.97	1		Parafango posteriore (ROSSO)	Rear mudguard (RED)	Garde-boue AR. (ROUGE)	Hinterradkotflügel (ROT)	Guardabarros tras. (ROJO)
6	021.43.048.80.51	1		Convogliatori - coppia (BIANCO)	Conveyors - pair (WHITE)	Convoyeurs - couple (BLANC)	Seiten - paar (WEISS)	Laterales - par (BLANCO)
6	021.43.048.80.97	1		Convogliatori - coppia (ROSSO)	Conveyors - pair (RED)	Convoyeurs - couple (ROUGE)	Seiten - paar (ROT)	Laterales - par (ROJO)
7	11.50355.000	1		Bullone 6.35 RS CH8	Bolt 6.35 RS CH8	Boulon 6.35 RS CH8	Bolzen 6.35 RS CH8	Tornillo 6.35 RS CH8
8	021.43.047.80.51	1		Fianchetti - coppia (BIANCO)	Side panels - pair (WHITE)	Coté laterals - couple (BLANC)	Seiten - paar (WEISS)	Flancos - par (BLANCO)
8	021.43.047.80.97	1		Fianchetti - coppia (ROSSO)	Side panels - pair (RED)	Coté laterals - couple (ROUGE)	Seiten - paar (ROT)	Flancos - par (ROJO)
9	021.43.046.00.00	1		Distanziale	Spacer	Entretoise	Distanzstück	Distanciadador
10	021.43.001.10.59	1		Sportello	Door	Abattant	Klappe	Registro
11	021.43.003.00.00	1		Perno	Pin	Pivot	Zapfen	Perno
12	036.43.006.10.59	1		Portatarga	Plate holder	Porte-plaque	Kennzeichenträger	Porta matr.
13	020.43.034.10.59	1	EU	Portatarga	Plate holder	Porte-plaque	Kennzeichenträger	Porta matr.
14	021.45.010.00.59	1		Kit protezioni stelo	Stem protection kit	Jeu protections tige	Schutzbalg gruppe	PJuego protecciones varilla
15	021.43.093.00.00	1		Cono	Cone	Cone	Konus	Cono
16	036.43.030.00.00	1		Tubo	Breather	Tuyau	Rohr	Tubo
17	021.43.037.00.59	1		Supporto parafango anteriore	Fender stay	Appui aile	Kotfluegelstuetze	Soporte de guardabarros
18	021.43.004.00.00	1		Molla	Spring	Ressort	Feder	Muelle
19	021.43.002.00.00	1		Staffa	Bracket	Support	Halterung	Soporte
20	31.29827.059	1		Vite M5x10	Screw M5x10	Vis M5x10	Schraube M5x10	Tornillo M5x10
21	020.43.007.00.00	1		Rubinetto benzina	Fuel cock.	Robinet melange	Kraftstoffhahn	Grifo mezcla
23	27.11320.000	1		Raccordo per cuffia	Cup fitting	Raccord pour recueil huile	Plattenanschlußstück	Racor para envoltura
24	27.43250.000	1		Rondella 6.24	Washer 6.24	Rondelle 6.24	U.Scheibe 6.24	Arandela 6.24
27	020.43.002.00.00	1		Distanziale serbatoio benzina	Spacer	Entretoise	Distanzstück	Distanciadador
28	032.37.013.00.00	2		Silentbloc	Silentbloc	Silentbloc	Puffer	Silent-block
29	31.30035.000	1		Vite M6x16	Screw M6x16	Vis M6x16	Schraube M6x16	Tornillo M6x16
30	13.62000.000	1		Distanziale	Spacer	Entretoise	Distanzstück	Distanciadador
31	11.50010.000	1		Vite M6x25	Screw M6x25	Vis M6x25	Schraube M6x25	Tornillo M6x25
32	31.89010.000	1		Vite spec. bloccaggio sella	Seat locking screw	Vis blocage selle	Schraube	Tornillo bloqueo sillin
33	021.43.025.00.00	1		Cavo antifurto casco	Helmet anti-theft wire	Câble antivol casco	Helmsicherungskabel	Cable antirrobo casco
34	31.26190.000	3		Vite M4x12 TCIC	Screw M4x12 TCIC	Vis M4x12 TCIC	Schraube M4x12 TCIC	Tornillo M4x12 TCIC
35	31.29910.000	2		Vite 5x12	Screw 5x12	Vis 5x12	Schraube 5x12	Tornillo 5x12
36	31.30035.000	1		Vite M6x25 TBCEI	Screw M6x25 TBCEI	Vis M6x25 TBCEI	Schraube M6x25 TBCEI	Tornillo M6x25 TBCEI
38	014.43.041.00.00	1		Distanziale	Spacer	Entretoise	Distanzstück	Distanciadador
39	021.40.040.80.00	1		Commutatore a chiave	Key operated switch	Commutateur à clef	Zündschalter	Conmutador de llave
40	13.62000.000	2		Distanziale	Spacer	Entretoise	Distanzstück	Distanciadador
41	11.48025.000	6		Vite 6x16 ch 8 rs	Screw 6x16 ch 8 rs	Vis 6x16 ch 8 rs	Schraube 6x16 ch 8 rs	Tornillo 6x16 ch 8 rs
42	27.42000.000	4		Rondella 6x18	Washer 6x18	Rondelle 6x18	U.Scheibe 6x18	Arandela 6x18
43	31.79960.000	8		Vite autofilettante M6x15	Self tapping screw M6x15	Vis taraud M6x15	Schraube, Blech M6x15	Tornillo autorrosc. M6x15
44	27.42000.000	1		Rondella 6x18	Washer 6x18	Rondelle 6x18	U.Scheibe 6x18	Arandela 6x18
45	15.14264.000	1		Fascetta	Clamp	Collier	Schelle	Abrazadera
46	13.54820.000	16		Distanziale 6,5x9,0x13,5	Spacer 6,5x9,0x13,5	Entretoise 6,5x9,0x13,5	Distanzstück 6,5x9,0x13,5	Distanciadador 6,5x9,0x13,5
47	11.47015.000	9		Vite M6x12	Screw M6x12	Vis M6x12	Schraube M6x12	Tornillo M6x12
48	020.43.012.00.00	2		Distanziale	Spacer	Entretoise	Distanzstück	Distanciadador
49	11.47015.000	6		Vite M6x12	Screw M6x12	Vis M6x12	Schraube M6x12	Tornillo M6x12
50	11.48025.000	3		Vite 6x16 ch 8 rs	Screw 6x16 ch 8 rs	Vis 6x16 ch 8 rs	Schraube 6x16 ch 8 rs	Tornillo 6x16 ch 8 rs
51	021.43.024.00.05	1		Boccola	Bush	Moyeu	Büchse	Buje
52	021.43.137.80.00	1		Tappo serbatoio benzina	Gasoline tank plug	Bouchon reservoir	Tankdeckel	Tapon deposito gasolina
53	021.43.027.00.00	2		Tampone h17	Buffer h17	Silentbloc h17	Puffer h17	Silent-block h17
54	021.43.026.00.00	2		Tampone h13	Buffer h13	Silentbloc h13	Puffer h13	Silent-block h13
55	021.43.052.82.51	1		Serie decalco completa (BIANCO)	Trimnings kit, assy. (WHITE)	Jeu enjoliveurs, complet (BLANC)	Abziehbildsatz, kpl (WEISS)	Juego calcom. compl. (BLANCO)
55	021.43.052.82.97	1		Serie decalco completa (ROSSO)	Trimnings kit, assy. (RED)	Jeu enjoliveurs, complet (ROUGE)	Abziehbildsatz, kpl (ROT)	Juego calcom. compl. (ROJO)
56	021.40.041.82.00	1		Serratura	Lock	Serrure	Schloß	Cerradura
57	021.43.012.00.00	1		Tubo serbatoio-carburatore	Tank-carburettor pipe	Tuyau réservoir-carburateur	Tankleitung-Vergaser	Tubo radiador-carburador

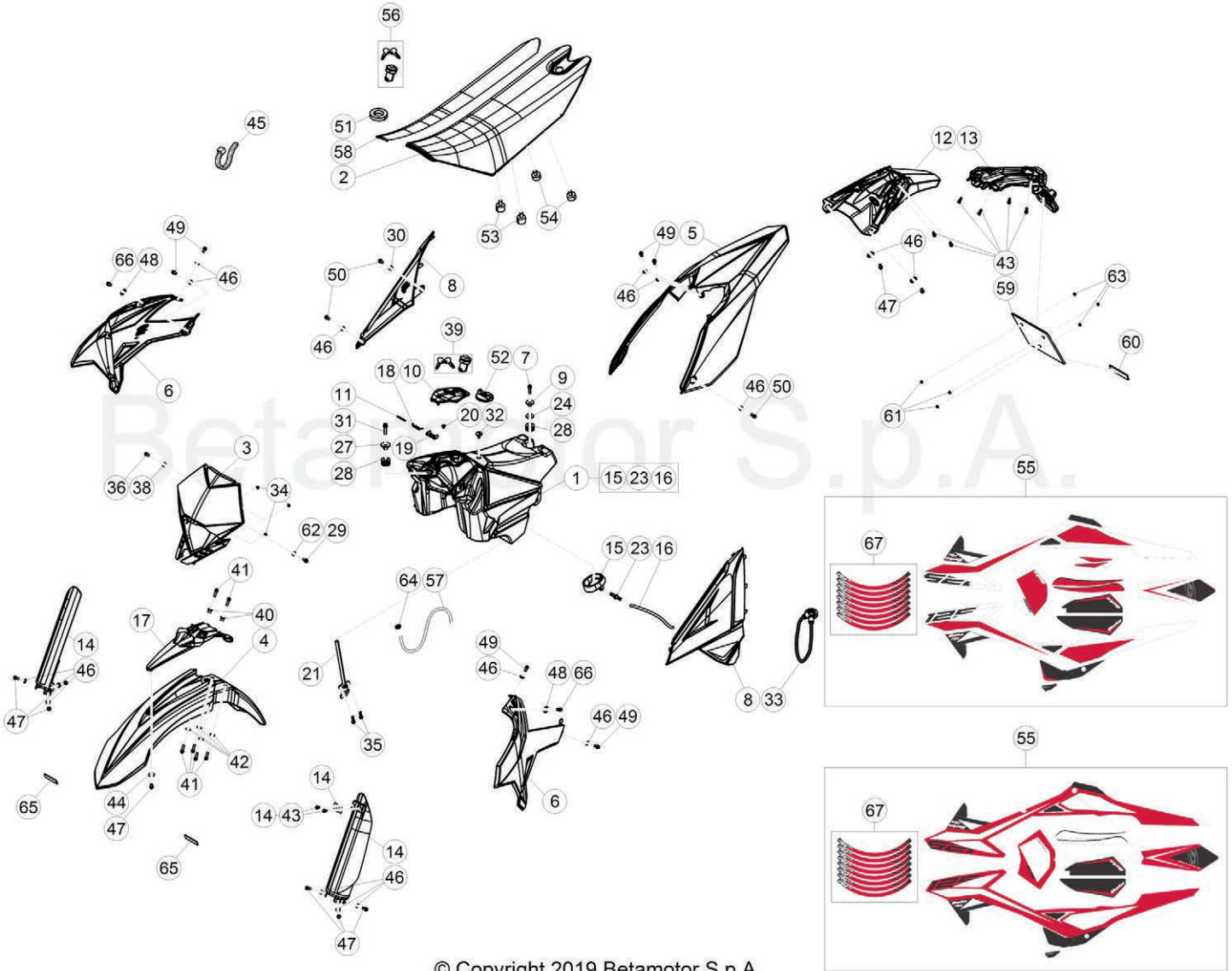

© Copyright 2019 Betamotor S.p.A.

Tav.43

Pos Loc Pos Ps Pos	Numero Number Numéro Número Nummer	Q.tà Q.ty Q.té M.ge C.ad	Nota Note Note Nota Anm.	Descrizione	Description	Désignation	Beschreibung	Descrìpziòn
								ENDURO
58	021.43.030.00.00	1		Coprisella	Saddle cover	Hous. de selle	Abdeckung	Cubierta sill.
59	018.43.010.10.59	1		Supporto targa	Licence plate bracket	Support plaque	Nummernschildträger	Soporte placa porta matrícula
60	12.33086.000	1		Catadiottro posteriore	Rear reflector	Catadioptré AR.	Rückstrahler hinten	Catafaro tras.
61	13.11000.000	3		Dado M6	Nut M6	Ecrou M6	Mutter M6	Tuerca M6
62	014.43.041.00.00	1		Distanziale	Spacer	Entretoise	Distanzstück	Distanciador
63	31.29850.000	3		Vite t.t.l.c. M5x12	Screw t.t.l.c. M5x12	Vis t.t.l.c. M5x12	Schraube t.t.l.c. M5x12	Tornillo t.t.l.c. M5x12
64	10.67460.000	1		Anello stringitubo	Pipe clamping ring	Anneau serre-tube	Schlauchschele	Anillo prensatubo
65	12.33062.000	2		Catadiottro laterale	Side reflector	Catadioptré latéral	Rückstrahler seitlich	Catafaro lateral
66	31.95510.000	2		Vite TBCE 6.12 flangiata 10.9	Flanged 10.9 bolt TBCE 6.12	Boulon 10.9 de bride 10.9	Schraube TBCE 6.12 Flanschen 10.9	Tornillo TBCE 6.12 con brida 10.9
67	021.43.049.82.00	1		Decalco cerchi	Trimnings kit for rims	Jeu enjoliv. jantes	Abziehbildsatz Felgen	Juego calcom. llantas

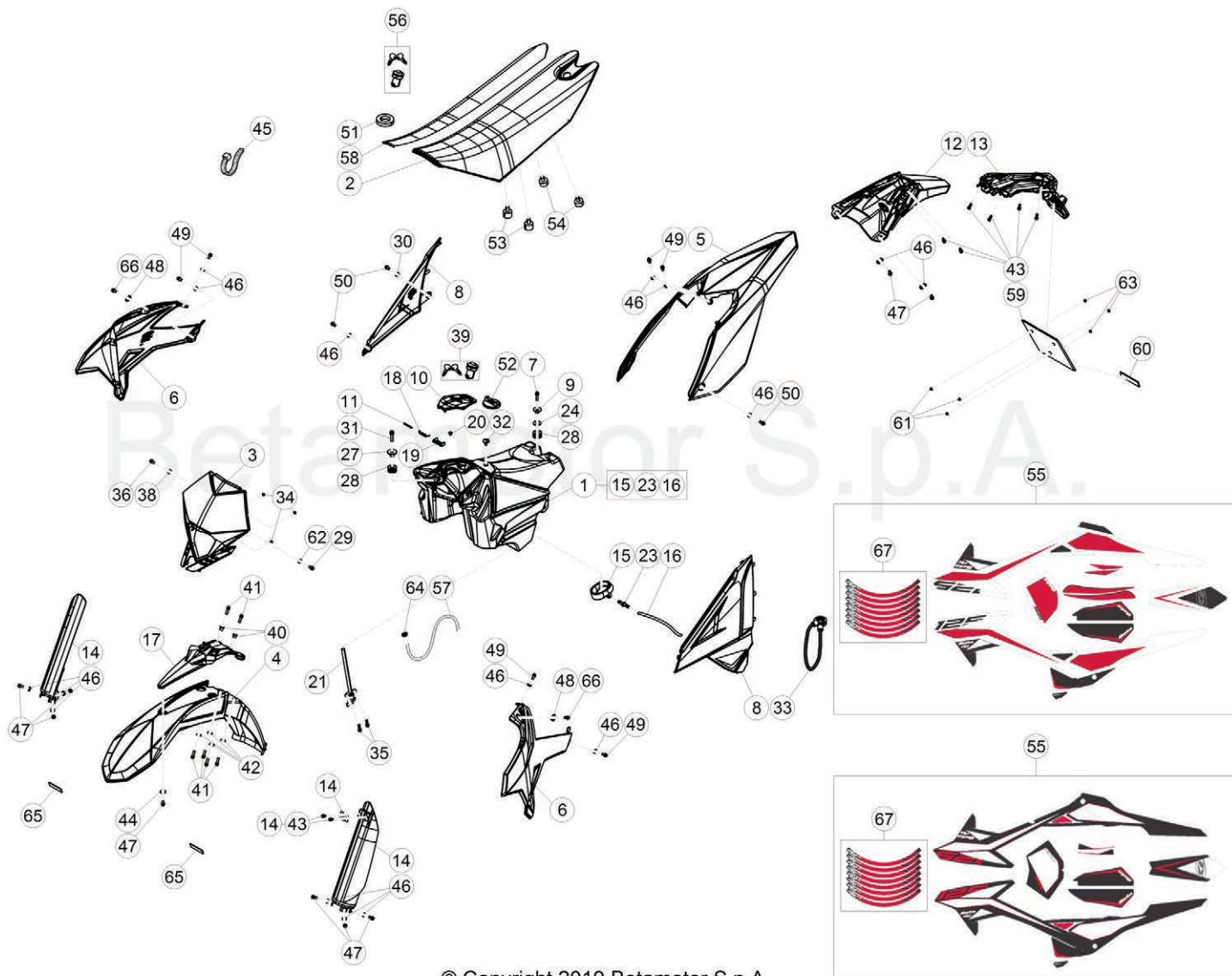

© Copyright 2019 Betamotor S.p.A.

Tav.43A

Pos Loc Pos Ps Pos	Numero Number Numéro Número Nummer	Q.tà Q.ty Q.té M.ge C.ad	Nota Note Note Nota Anm.	Descrizione	Description	Désignation	Beschreibung	Descrìcion
								MOTARD
1	021.43.019.80.59	1		Serbatoio completo	Fuel tank	Réservoir carburant	Kraftstofftank	Deposito gasolina
2	021.43.022.00.00	1		Sella	Seat	Siege	Sattel	Sillin
3	020.43.017.87.51	1		Mascherina portafaro (BIANCO)	Headlight holder (WHITE)	Cache porte-phare (BLANC)	Lampenmaske (WEISS)	Portafaro ant. con adhesivo (BLANCO)
3	020.43.017.87.59	1		Mascherina portafaro (NERO)	Headlight holder (BLACK)	Cache porte-phare (NOIR)	Lampenmaske (SCHWARZ)	Portafaro ant. con adhesivo (NEGRO)
4	021.43.045.10.51	1		Parafango anteriore (BIANCO)	Front mudguard (WHITE)	Garde-boue AV. (BLANC)	Vorderes Schutzblech (WEISS)	Guardabarros delantero (BLANCO)
4	021.43.045.10.59	1		Parafango anteriore (NERO)	Front mudguard (BLACK)	Garde-boue AV. (NOIR)	Vorderes Schutzblech (SCHWARZ)	Guardabarros delantero (NEGRO)
5	026.43.033.00.51	1		Parafango posteriore (BIANCO)	Rear mudguard (WHITE)	Garde-boue AR. (BLANC)	Hinterradkotflügel (WEISS)	Guardabarros tras. (BLANCO)
5	026.43.033.00.59	1		Parafango posteriore (NERO)	Rear mudguard (BLACK)	Garde-boue AR. (NOIR)	Hinterradkotflügel (SCHWARZ)	Guardabarros tras. (NEGRO)
6	021.43.048.80.51	1		Convogliatori - coppia (BIANCO)	Conveyors - pair (WHITE)	Convoyeurs - couple (BLANC)	Seiten - paar (WEISS)	Laterales - par (BLANCO)
6	021.43.048.80.59	1		Convogliatori - coppia (NERO)	Conveyors - pair (BLACK)	Convoyeurs - couple (NOIR)	Seiten - paar (SCHWARZ)	Laterales - par (NEGRO)
7	11.50355.000	1		Bullone 6.35 RS CH8	Bolt 6.35 RS CH8	Boulon 6.35 RS CH8	Bolzen 6.35 RS CH8	Tornillo 6.35 RS CH8
8	021.43.047.80.51	1		Fianchetti - coppia (BIANCO)	Side panels - pair (WHITE)	Coté laterals - couple (BLANC)	Seiten - paar (WEISS)	Flancos - par (BLANCO)
8	021.43.047.80.59	1		Fianchetti - coppia (NERO)	Side panels - pair (BLACK)	Coté laterals - couple (NOIR)	Seiten - paar (SCHWARZ)	Flancos - par (NEGRO)
9	021.43.046.00.00	1		Distanziale	Spacer	Entretoise	Distanzstück	Distanciadador
10	021.43.001.10.59	1		Sportello	Door	Abattant	Klappe	Registro
11	021.43.003.00.00	1		Perno	Pin	Pivot	Zapfen	Perno
12	036.43.006.10.59	1		Portatarga	Plate holder	Porte-plaque	Kennzeichenträger	Porta matr.
13	020.43.034.10.59	1	EU	Portatarga	Plate holder	Porte-plaque	Kennzeichenträger	Porta matr.
14	021.45.010.00.59	1		Kit protezioni stelo	Stem protection kit	Jeu protections tige	Schutzbalg gruppe	PJuego protecciones varilla
15	021.43.093.00.00	1		Cono	Cone	Cone	Konus	Cono
16	036.43.030.00.00	1		Tube	Pipe	Tuyau	Rohr	Tube
17	021.43.037.00.59	1		Supporto parafango	Fender stay	Appui aile	Kotflügelstuetze	Soporte de guardabarros
18	021.43.004.00.00	1		Molla	Spring	Ressort	Feder	Muelle
19	021.43.002.00.00	1		Staffa	Bracket	Support	Halterung	Soporte
20	31.29827.059	1		Vite M5x10	Screw M5x10	Vis M5x10	Schraube M5x10	Tornillo M5x10
21	020.43.007.00.00	1		Rubinetto benzina	Fuel cock.	Robinet melange	Kraftstoffhahn	Grifo mezcla
23	27.11320.000	1		Raccordo per cuffia	Cup fitting	Raccord pour recueil huile	Plattenanschlußstück	Racor para envoltura
24	27.43250.000	1		Rondella 6.24	Washer 6.24	Rondelle 6.24	U.Scheibe 6.24	Arandela 6.24
27	020.43.002.00.00	1		Distanziale serbatoio benzina	Spacer	Entretoise	Distanzstück	Distanciadador
28	032.37.013.00.00	2		Silentbloc	Silentbloc	Silentbloc	Puffer	Silent-block
29	31.30035.000	1		Vite M6x25 TBCEI	Screw M6x25 TBCEI	Vis M6x25 TBCEI	Schraube M6x25 TBCEI	Tornillo M6x25 TBCEI
30	13.62000.000	1		Distanziale	Spacer	Entretoise	Distanzstück	Distanciadador
31	11.50010.000	1		Vite M6x25	Screw M6x25	Vis M6x25	Schraube M6x25	Tornillo M6x25
32	31.89010.000	1		Vite spec. bloccaggio sella	Seat locking screw	Vis blocage selle	Schraube	Tornillo bloqueo sillin
33	021.43.025.00.00	1		Cavo antifurto casco	Helmet anti-theft wire	Câble antivol casque	Helmsicherungskabel	Cable antirrobo casco
34	31.26190.000	3		Vite M4x12 TCIC	Screw M4x12 TCIC	Vis M4x12 TCIC	Schraube M4x12 TCIC	Tornillo M4x12 TCIC
35	31.29910.000	2		Vite 5x12	Screw 5x12	Vis 5x12	Schraube 5x12	Tornillo 5x12
36	31.30035.000	1		Vite M6x25 TBCEI	Screw M6x25 TBCEI	Vis M6x25 TBCEI	Schraube M6x25 TBCEI	Tornillo M6x25 TBCEI
38	014.43.041.00.00	1		Distanziale	Spacer	Entretoise	Distanzstück	Distanciadador
39	021.40.040.80.00	1		Commutatore a chiave	Key operated switch	Commutateur à clef	Zündschalter	Conmutador de llave
40	13.62000.000	2		Distanziale	Spacer	Entretoise	Distanzstück	Distanciadador
41	11.48025.000	6		Vite 6x16 ch 8 rs	Screw 6x16 ch 8 rs	Vis 6x16 ch 8 rs	Schraube 6x16 ch 8 rs	Tornillo 6x16 ch 8 rs
42	27.42000.000	4		Rondella 6x18	Washer 6x18	Rondelle 6x18	U.Scheibe 6x18	Arandela 6x18
43	31.79960.000	8		Vite autofilettante M6x15	Self tapping screw M6x15	Vis taraud M6x15	Schraube, Blech M6x15	Tornillo autorrosc. M6x15
44	27.42000.000	1		Rondella 6x18	Washer 6x18	Rondelle 6x18	U.Scheibe 6x18	Arandela 6x18
45	15.14264.000	1		Fascetta	Clamp	Collier	Schelle	Abrazadera
46	13.54820.000	16		Distanziale 6,5x9,0x13,5	Spacer 6,5x9,0x13,5	Entretoise 6,5x9,0x13,5	Distanzstück 6,5x9,0x13,5	Distanciadador 6,5x9,0x13,5
47	11.47015.000	9		Vite M6x12	Screw M6x12	Vis M6x12	Schraube M6x12	Tornillo M6x12
48	020.43.012.00.00	2		Distanziale	Spacer	Entretoise	Distanzstück	Distanciadador
49	11.47015.000	6		Vite M6x12	Screw M6x12	Vis M6x12	Schraube M6x12	Tornillo M6x12
50	11.48025.000	3		Vite 6x16 ch 8 rs	Screw 6x16 ch 8 rs	Vis 6x16 ch 8 rs	Schraube 6x16 ch 8 rs	Tornillo 6x16 ch 8 rs
51	021.43.024.00.05	1		Boccola	Bush	Moyeu	Büchse	Buje
52	021.43.137.80.00	1		Tappo serbatoio benzina	Gasoline tank plug	Bouchon reservoir	Tankdeckel	Tapon deposito gasolina
53	021.43.027.00.00	2		Tampone h17	Buffer h17	Silentbloc h17	Puffer h17	Silent-block h17
54	021.43.026.00.00	2		Tampone h13	Buffer h13	Silentbloc h13	Puffer h13	Silent-block h13
55	021.43.052.82.51	1		Serie decalco completa (BIANCO)	Trimnings kit, assy. (WHITE)	Jeu enjoliveurs, complet (BLANC)	Abziehbildsatz, kpl (WEISS)	Juego calcom. compl. (BLANCO)
55	021.43.052.82.59	1		Serie decalco completa (NERO)	Trimnings kit, assy. (BLACK)	Jeu enjoliveurs, complet (NOIR)	Abziehbildsatz, kpl (SCHWARZ)	Juego calcom. compl. (NEGRO)
56	021.40.041.82.00	1		Serratura	Lock	Serrure	Schloß	Cerradura
57	021.43.012.00.00	1		Tube serbatoio-carburatore	Tank-carburettor pipe	Tuyau réservoir-carburateur	Tankleitung-Vergaser	Tube radiador-carburador



© Copyright 2019 Betamotor S.p.A.

Tav.43A

Pos Loc Pos Ps Pos	Numero Number Numéro Número Nummer	Q.tà Q.ty Q.té M.ge C.ad	Nota Note Note Nota Anm.	Descrizione	Description	Désignation	Beschreibung	Descrìcion
								MOTARD
58	021.43.030.00.00	1		Coprisella	Saddle cover	Hous. de selle	Abdeckung	Cubierta sill.
59	018.43.010.10.59	1		Supporto targa	Licence plate bracket	Support plaque	Nummernschildträger	Soporte placa porta matrícula
60	12.33086.000	1		Catadiottro posteriore	Rear reflector	Catadioptré AR.	Rückstrahler hinten	Catafaro tras.
61	13.11000.000	3		Dado M6	Nut M6	Ecrou M6	Mutter M6	Tuerca M6
62	014.43.041.00.00	1		Distanziale	Spacer	Entretoise	Distanzstück	Distanciador
63	31.29850.000	3		Vite	Screw	Vis	Schraube	Tornillo
64	10.67460.000	1		Anello stringitubo	Pipe clamping ring	Anneau serre-tube	Schlauchschelle	Anillo prensatubo
65	12.33062.000	2		Catadiottro laterale	Side reflector	Catadioptré latéral	Rückstrahler seitlich	Catafaro lateral
66	31.95510.000	2		Vite TBCE 6.12 flangiata 10.9	Flanged 10.9 bolt TBCE 6.12	Boulon 10.9 de bride 10.9	Schraube TBCE 6.12	Tornillo TBCE 6.12 con brida 10.9
67	021.43.049.82.00	1		Decalco cerchi	Trimnings kit for rims	Jeu enjoliv. jantes	Abziehbildsatz Felgen	Juego calcom. llantas

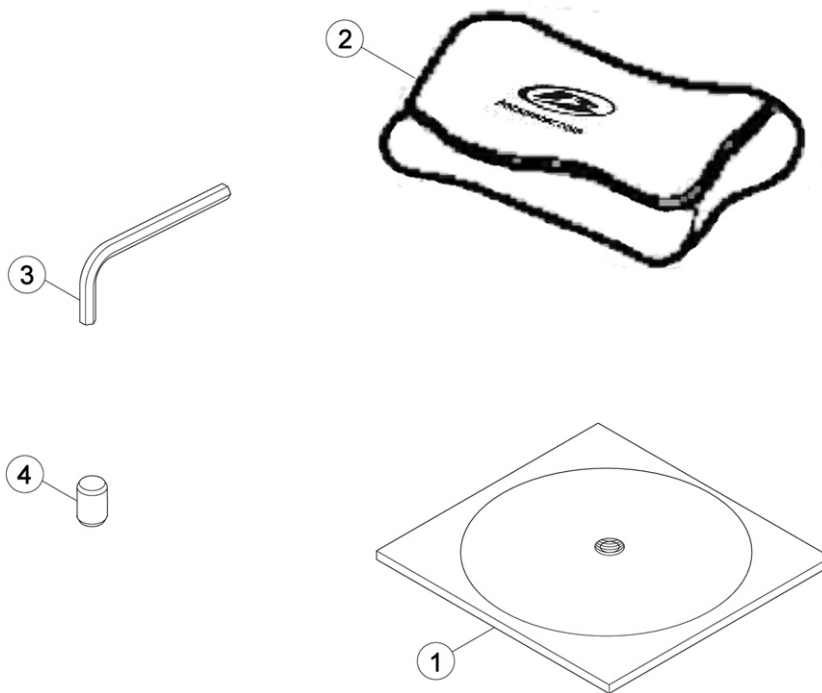

Pos Loc Pos Ps Pos	Numero Number Numéro Número Nummer	Q.tà Q.ty Q.té M.ge C.ad	Nota Note Note Nota Anm.	Descrizione	Description	Désignation	Beschreibung	Descripción
1	021.44.015.00.00	1		CD Manuale uso e manutenzione	Owner's manual CD-Rom	CD-Rom Manuel d'utilisation et entretien	CD-Rom Bedienungs und Wartungshandbuch	CD-Rom Manual de Uso y Manutención
2	021.44.003.80.00	1		Borsa attrezzi	Tool roll	Trousse à outils	Werkzeugtasche	Bolsa herramientas
3	020.44.003.00.00	1		Chiave a brugola 6mm	Allen wrench 6mm	Clé Allen 6mm	Sechskantschlüssel 6mm	Llave de imbus 6mm
4	020.44.004.00.00	1		Bussola 8	Bush 8	Joint 8	Buchse 8	Buje 8



Handwriting practice area consisting of 20 horizontal dotted lines.



